

Copy No. \_\_\_\_\_

TOWN OF DEDHAM, MASSACHUSETTS  
CONTRACT DOCUMENTS  
FOR

CY2022 ASPHALT PAVING AND RESURFACING



February 2022

Town of Dedham  
Department of Public Works &  
Department of Infrastructure Engineering

Leon Goodwin, Town Manager  
Joseph M. Flanagan, Director of Public Works  
Jason L. Mammone, P.E., Director of Engineering

## TABLE OF CONTENTS

	<u>Section Number</u>
<u>Bidding And Contract Requirements</u>	
Invitation To Bid	00020
Instructions To Bidders	00100
Bid Form	00300
Agreement	00500
Construction Performance Bond	00610
Construction Payment Bond	00620
Certificates of Insurance	00650
General Conditions	00700
Supplemental General Conditions	00800
Excerpts from Applicable State Law	00850
Special Requirements	01015
Measurement and Payment	01025

### Attachments

Attachment A - Wage Rates and Certificate of Compliance

Attachment B - (MBE/EEO/AA) Policies

1. Commonwealth of Massachusetts

Attachment C – Monthly Price Adjustments

1. Document 00811 – Hot Mix Asphalt Mixtures
2. Document 00812 – Diesel Fuel and Gasoline
3. Document 00814 – Portland Cement Concrete Mixes

Attachment D - Town of Dedham Design and Construction Standards

Attachment E - Massachusetts Highway Department Wheel Chair Ramp Standards

SECTION 00020

INVITATION FOR BIDS

Sealed bids for furnishing the following item(s) will be received at the Engineering Department Office located at the Department of Public Works facility, 55 River Street, Dedham, MA 02026 until the time specified below at which time the proposals will be publicly opened and read:

<u>ITEM</u>	<u>BID OPENING</u>
Bid: <b>CY2022 ASPHALT PAVING AND RESURFACING</b>	<b>March 10, 2022</b>

Specifications and bid forms may be obtained, by appointment ONLY, at the Engineering Department Office located at the Department of Public Works facility, 55 River Street, Dedham, MA, after February 9, 2022 between 8:00 A.M. and 2:00 P.M., upon payment of a nonrefundable fee of \$50.00 payable to the Town of Dedham. Cash is not acceptable. Checks shall be made payable to the Town of Dedham. Bidders may also obtain a **FREE** PDF version of the specifications from the Town of Dedham's website <http://www.dedham-ma.gov/departments/engineering/invitation-for-bids-proposals>.

Contractors must be prequalified with MassDOT with the class of work as, Pavement Surfacing, for the project with an estimated value of \$3,813,513.45 in accordance with 720 CMR 5.00, "Prequalification of Contractors". Contractors seeking "information only" bid documents are not required to be prequalified.

This Contract contains price adjustments for Portland and bituminous concrete mixtures, diesel fuel, and gasoline. The base price for Portland cement is \$162.28 per ton, for liquid asphalt is \$625.00 per ton, for diesel fuel is \$2.712 per gallon, for gasoline is \$2.632 per gallon.

Bids will be opened in the Department of Public Works facility, 55 River Street, Dedham, MA 02026, at 10:00 AM. Bid openings will not be open to the public, however the bid opening will be available through video conference using Zoom. Zoom can be downloaded for free at [www.zoom.us](http://www.zoom.us) to access video conferencing, or the conference can be joined by audio only without the use or need of the Zoom application at all. All pertinent information for the Zoom video conference is shown below:

***Topic: CY2022 Asphalt Paving & Resurfacing - Bid Opening***

***Time: March 10, 2022 10:00 AM Eastern Time (US and Canada)***

*Join Zoom Meeting: <https://zoom.us/j/5274574085>*

*Meeting ID: 527 457 4085*

*Dial by your location:*

*+1 646 558 8656 US (New York)*

*+1 301 715 8592 US (Washington D.C)*

*+1 346 248 7799 US (Houston)*

*+1 669 900 9128 US (San Jose)*

*+1 253 215 8782 US (Tacoma)*

*Find your local number: <https://zoom.us/u/adb77k4K1>*

Bid opening will be recorded and available on the Town of Dedham website following the bid opening. Each Bid must be accompanied by a bid security consisting of a BID BOND, CASH, or, CERTIFIED CHECK issued by a responsible bank or trust company in the amount of 5% of the bid price.

A performance bond in an amount equal to 100 percent of the total amount of the bid with a surety company qualified to do business in the Commonwealth of Massachusetts will be required for the faithful performance of the contract as well as a labor and materials bond in an amount equal to 100 percent of the total bid amount.

All bids for this project are subject to applicable public bidding laws of Massachusetts, including **G.L. c.30, §39M** as amended.

The term of this contract shall extend from April 21, 2022 through December 31, 2022. The Town, at its sole discretion with consent of the contractor, shall have the option to extend the contract for one (1) additional year period, January 1, 2023 through December 31, 2023, with no changes in the contract price or terms and conditions and at its sole discretion with consent of the contractor, the option to extend the contract for one (1) additional year period, January 1, 2024 through December 31, 2024. The contractor is cautioned that there is no guarantee of consistent workload volume throughout the optional contract extension periods. The contractor must also maintain MassDOT qualification for each following option year in accordance with 720 CMR 5.00 to be eligible for the optional contract extension.

Attention is directed to the minimum wage rates to be paid as determined by the Commissioner of Labor and Industries under the provisions of Massachusetts General Laws, Chapter 149, Section 26 to 27D inclusive.

Selection of the contractor will be based upon bidder qualifications, including evidence of past performance in similar projects, and bid price. The contract will be awarded to the bidder deemed by the awarding authority to be the lowest responsible and eligible bidder.

The Town of Dedham is an affirmative action/equal opportunity owner/purchaser.

The bidder agrees that its bid shall be good and may not be withdrawn for a period of 30 days, Saturdays, Sundays and legal holidays excluded, after the opening of the bids.

The Town reserves the right to waive any informalities, to accept or reject, in whole or in part any or all bids, or take whatever other action may be deemed to be in the best interest of the Town.

The Town of Dedham

By Leon Goodwin

Its Town Manager

## SECTION 00100

### INSTRUCTIONS TO BIDDERS

#### 1. Receipt and Opening of Bids

The Town of Dedham, Massachusetts, herein called the Owner, acting by and through its Town Manager, will receive sealed Bids for CY2022 ASPHALT PAVING AND RESURFACING.

Such bids addressed to the Engineering Department, 55 River Street, Dedham, MA 02026, and endorsed BID for the CY2022 ASPHALT PAVING & RESURFACING CONTRACT will be received at the Engineering Department office, located at the Department of Public Works facility, 55 River Street, Dedham, MA, 02026 until 10:00 AM prevailing time, on Thursday, March 10, 2022 at which time and place said bids will be opened and read aloud. The DPW facility is currently closed to the public, sealed bids that are sent via an independent courier (i.e. FedEx, UPS, etc.) should not require a signature, bids shall be placed in the mailbox located at the front door of the DPW facility. Bid opening will not be open to the public, however the bid opening will be available on the Town of Dedham website following the bid opening.

Any bid may be withdrawn prior to the above scheduled time for the opening of bids or authorized postponement thereof. Any bid received after the time and date specified will not be considered. The bidder agrees that this bid shall be good and may not be withdrawn for a period of 30 days, Saturdays, Sundays, and legal holidays excluded, after the opening of bids.

#### 2. Location and Work to be Done

The Work consists of various forms of asphalt paving and resurfacing including but not limited to full depth reclamation, grading and compaction, cold planing, paving, installation of bituminous and granite curbing, installation and repair of bituminous and concrete sidewalks, installation or replacement of drainage pipes and structures, and other miscellaneous related work.

The location, general characteristics, and principal details of the Work are shown on the Town of Dedham's approved CY2022-CY2022 Road Program, available at <http://www.dedham-ma.gov/departments/engineering/reports>. The exact location and work to be done are shown for information only and are subject to modifications, deletions, and additions as deemed necessary by the Owner.

Additional drawings showing details in accordance with which the Work is to be done may be furnished by addendum from time to time during the bidding period by the Owner or its Engineer, and shall then become a part of the Contract Documents.

The Contractor shall furnish all labor, services, materials, equipment, plant, machinery, apparatus, appliances, tools, supplies, and all other things necessary to do all work required for the completion of each item of the Work and as herein specified.

The Work to be done and paid for under any item shall not be limited to the exact extent mentioned or described but shall include all incidental work necessary or customarily done for the completion of that item.

3. Preparation of Bid

Each bid must be submitted on the prescribed form. All blank spaces for bid prices must be filled in, in ink or typewritten, in both words and figures.

Each bid must be submitted in a sealed envelope bearing on the outside the name of the bidder, his address, and endorsed with the name of the project as specified in Receipt and Opening of Bids, above.

If forwarded by mail, the sealed envelope containing the bid must be enclosed in another envelope addressed as specified in Receipt and Opening of Bids, above.

4. Bid Opening Procedure

The following list of requirements shall apply to each filed bid. Bids not meeting all the requirements for timeliness and security will be rejected without opening; bids not meeting signature and addenda requirements will be rejected prior to checking of bid amounts.

Bids shall be filed at the place and before the time specified in Receipt and Opening of Bids, above.

Properly executed bid security shall be placed in a sealed envelope and shall be attached to the outside of the envelope containing the bid.

Bid signatures will be checked.

All addenda, including a mechanism to confirm receipt, shall be issued by the Town by any means deemed suitable to the Town to all bidders no later than five days prior to the date established for the submission of bids. All bidders shall include with their bids the written acknowledgement form provided in Section 00300, FORM OF GENERAL BID. Failure of any bidder to receive any such addendum or interpretation shall not relieve such bidder from any obligation under his bid as submitted.

The total dollar amount of each bid will be read, and the three apparent lowest bids will be selected for further consideration. These three apparent low bids will be read aloud for the benefit of the other bidders and the bid opening procedure will be closed. Following the bid opening, all bids shall be made available as a public record.

5. Telegraphic Modification

Any bidder may modify his bid by telegraphic communication at any time prior to the scheduled closing time for receipt of bids, provided such telegraphic communication is received by the Owner prior to the closing time, and, provided further, the Owner is satisfied that a written confirmation of the telegraphic modification over the signature of the bidder was mailed prior to the closing time.

The telegraphic communication shall not reveal the bid price but shall provide the addition or subtraction or other modification so that the final prices or terms will not be known by the Owner until the sealed bid is opened. If written confirmation is not received within two days from the closing time, no consideration will be given to the telegraphic communication.

6. Ability and Experience of Bidder

No award will be made to any bidder who cannot satisfy the Owner that he has sufficient ability and experience in this class of work and sufficient capital and plant to enable him to prosecute and complete the work successfully within the time named. The Owner's decision or judgment on these matters will be final, conclusive, and binding.

The Owner may make such investigations as he deems necessary, and the bidder shall furnish to the Owner, under oath if so required, all such information and data for this purpose as the Owner may request.

7. Conditions of Work

Each bidder must familiarize himself fully with the conditions relating to the construction of the project and the employment of labor thereon. Failure to do so will not relieve a successful bidder of his obligation to furnish all material and labor necessary to carry out the provisions of his contract. Insofar as possible the Contractor, in carrying out his work, must employ such methods or means as will not cause any interruption of or interference with the work of any other Contractor.

8. Addenda and Interpretations

No interpretation of the meaning of the plans, specifications or other prebid documents will be made to any bidder orally. All information given to bidders other than by means of the plans, specifications, or by addenda, as described below, is given informally and shall not be used as the basis of a claim against the Owner.

Every request for such interpretation should be in writing addressed to the Director of Engineering, 55 River Street, Dedham, MA 02026, and to be given consideration must be received at least seven days prior to the date fixed for the opening of bids. Any and all such interpretations and any supplemental instructions will be in the form of a written

addenda to the specifications and issued as described above in Part 4, "Bid Opening Procedure". Failure of any bidder to receive any such addendum or interpretation shall not relieve such bidder from any obligation under his bid as submitted. All addenda so issued shall become part of the Contract Documents.

9. Security for Faithful Performance

Simultaneously with his delivery of the executed Contract, the Contractor shall furnish a surety bond or bonds as security for faithful performance of this contract and for the payment of all persons performing labor and materials under this contract as specified in Section 00700, GENERAL CONDITIONS included herein. The surety on such bond or bonds shall be a surety company qualified to do business under the laws of the Commonwealth and satisfactory to the Owner. The bonds shall remain in force for one year after final acceptance of the work by the Owner, unless the Owner, in writing, releases the Contractor from the obligation sooner.

10. Power of Attorney

Attorneys-in-fact who sign Contract bonds must file with each bond a certified and effectively dated copy of their power of attorney.

11. Laws and Regulations

The bidder's attention is directed to the fact that all applicable State laws, municipal ordinances, and the rules and regulations of all authorities having jurisdiction over construction of the project shall apply to the contract throughout, and they will be deemed to be included in the Contract the same as though herein written out in full. Attention is directed to Section 00850 and to other applicable sections of this specification.

12. Liquidated Damages for Failure to Enter into Contract

The successful bidder, upon his failure or refusal to execute and deliver the Contract and bonds required within 10 days after he/she has received notice of the acceptance of his/her bid, shall forfeit to the Owner, as liquidated damages for such failure or refusal, a portion of security deposited with his/her bid, but the amount forfeited shall not exceed the difference between his/her bid price and the bid price of the next lowest responsible and eligible bidder. In case of death, disability, bonafide clerical or mechanical error of a substantial nature, or other similar unforeseen circumstances affecting the bidder, his/her bid deposit will be returned.

13. Obligation of Bidder

At the time of the opening of bids each bidder will be presumed to have inspected the site and to have read and to be thoroughly familiar with the Contract Documents (including



all addenda). The failure or omission of any bidder to examine any form, instrument, or document shall in no way relieve any bidder from any obligation in respect of his bid.

14. Information Not Guaranteed

All information given in the Contract Documents relating to subsurface and other conditions, natural phenomena, existing pipes, and other structures is from the best sources at present available to the Owner. All such information is furnished only for the information and convenience of bidders and is not guaranteed.

It is agreed and understood that the Owner does not warrant or guarantee that the subsurface or other conditions, natural phenomena, existing pipes, or other structures encountered during construction will be the same as those indicated in the Contract Documents.

It is further agreed and understood that no bidder or Contractor shall use or be entitled to use any of the information made available to him or obtained in any examination made by him in any manner as a basis of or ground for any claim or demand against the Owner or the Engineer, arising from or by reason of any variance which may exist between the information made available and the actual subsurface or other structures actually encountered during the construction work, except as may otherwise be expressly provided for in the Contract Documents.

15. Bid Security

Each bid must be accompanied by a certified check, a bid bond, cash, a treasurer's or cashier's check, payable to the Owner, in the amount stated in Section 00020, INVITATION TO BID. Such checks will be returned to all except the three lowest responsible and eligible bidders within five days, Saturdays, Sundays, and legal holidays excluded, after the opening of bids, and the remaining checks will be returned promptly after the Owner and the accepted bidder have executed the Contract, or if no notice of intent to award has been presented to the selected contractor within 30 days, Saturdays, Sundays and holidays excluded, after the date of the opening of bids, upon demand of the bidder at any time thereafter.

16. Right to Reject Bid

The Owner reserves the right to waive any informalities or reject any and all bids, should the Owner deem it to be in the public interest to do so.

The Owner may also reject bids which in its sole judgment are either incomplete, conditional, obscure or not responsive or which contain additions not called for, erasures not properly initialed, alterations, or similar irregularities, or the Owner may waive such omissions, conditions or irregularities.

The Owner also reserves the right to reject the bid of any bidder that the Owner considers to be unqualified based on the criteria set forth in Article 6 herein.

17. Time for Completion

The bidder must agree to commence work within ten (10) days of the date of the Notice to Proceed and to fully complete the project within the time limit stated in Section 00300, FORM OF GENERAL BID.

18. Comparison of Bids

Bids will be compared on the basis of the quantities and unit and lump sum prices set forth in the bid forms.

In the event that there is a discrepancy in Section 00300, FORM OF GENERAL BID between the lump sum or unit prices written in words and figures, the prices written in words will govern.

The Owner agrees to examine and consider each FORM OF GENERAL BID submitted in consideration of the qualifications of the bidder and the bidder's agreements, as hereinabove set forth and as set forth in Section 00300, FORM OF GENERAL BID.

19. Award of Contract

The Contract will be awarded to "the lowest responsible and eligible bidder" pursuant to General Laws Chapter 30, Section 39M, as amended. Such a bidder shall possess the skill, ability and integrity necessary for the faithful performance of the work, shall be able to furnish labor that can work in harmony with all other elements of labor employed, or to be employed, in the work, and shall otherwise comply with all applicable provisions of law.

The term of this contract shall extend from April 21, 2022 through December 31, 2022. The Town, at its sole discretion, shall have the option to extend for one (1) additional year period, January 1, 2023 through December 31, 2023, with no changes in the contract price or terms and conditions, and at its sole discretion with consent of the contractor, the option to extend for an additional one (1) year period, January 1, 2024 through December 31, 2024 with no changes in the contract price or terms and conditions.

Please be advised that funding for this project has not yet been obtained; therefore, any contract awarded pursuant to this invitation for Bids shall be subject to and contingent upon appropriation of sufficient funds by Town Meeting.

20. Statutes Regulating Competitive Bidding

Any bid which does not comply with the provisions of Massachusetts General Laws Chapter 30, Section 39M as amended, need not be accepted and the Owner may reject every such bid.

21. Wage Rates

Prevailing Wage Rates as determined by the Commissioner of Department of Labor and Industries under the provision of the Massachusetts General Laws, Chapter 149, Section 26 to 27G, as amended, apply to this project. It is the responsibility of the contractor, before bid opening, to request if necessary, any additional information on Prevailing Wage Rates for those tradespeople who may be employed for the proposed work under this contract.

State schedules of Prevailing wage rates are included in the Supplemental General Conditions section of the contract documents.

22. Contractor Records

The Contractor shall comply with the provisions of Massachusetts General Laws, Chapter 30, Section 39R, concerning Contractor records.

23. Insurance

The Contractor shall carry and continuously maintain until completion of the Contract, insurance as specified in the Supplemental General Conditions and in such form as shall protect him performing work covered by this Contract, or the Town of Dedham and its employees, agents and officials, from all claims and liability for damages for bodily injury, including accidental death, and for property damage, which may arise from operations under this Contract. The Contractor covenants and agrees to hold the Town and its employees, agents and officials harmless from loss or damage due to claims for personal injury and/or property damage arising from, or in connection with operations under this Contract.

24. Affirmative Action/Equal Employment Opportunity Laws and Regulations

The Town of Dedham is an affirmative action/equal opportunity owner/purchaser. The bidder's attention is directed to all applicable State Laws, Town Bylaws, and rules and regulations regarding affirmative action/equal employment opportunity requirements. Failure of a bidder to comply with any such law, bylaw, rule or regulation shall constitute grounds for the Town to reject a bid or to otherwise reject or terminate the award of the contract pursuant to these contract documents.

SECTION 00300

FORM OF GENERAL BID

Bid of \_\_\_\_\_ (hereinafter called "Bidder")\*

(\_\_\_\_) a corporation, organized and existing under the laws of the state of  
\_\_\_\_\_

(\_\_\_\_) a partnership

(\_\_\_\_) a joint venture

(\_\_\_\_) an individual  
doing business as \_\_\_\_\_

To the Town of Dedham, Massachusetts (hereinafter called "Owner").

Gentlemen:

The Bidder, in compliance with your invitation for bids for CY2022 ASPHALT PAVING AND RESURFACING, having examined the plans and specifications with related documents and the site of the proposed work, and being familiar with all of the conditions surrounding the construction of the proposed project including the availability of materials and labor, hereby proposes to furnish all labor, materials, and supplies, and to construct the project in accordance with the contract documents within the time set forth below, and at the prices stated below. These prices are to cover all expenses incurred in performing the work required under the contract documents, of which this proposal is a part.

The Bidder hereby agrees to commence work under this contract on or before a date to be specified in written "Notice to Proceed" of the Owner, and to fully complete the project by December 31, 2022. The Bidder further agrees to pay as liquidated damages the sum of one thousand (\$1,000) Dollars for each consecutive calendar day thereafter as hereinafter provided in Section 00700 GENERAL CONDITIONS.

\_\_\_\_\_  
\*Insert corporation, partnership or individual as applicable.

Bidder acknowledges receipt of the following addenda:

No. \_\_\_\_\_ Dated: \_\_\_\_\_

No. \_\_\_\_\_ Dated: \_\_\_\_\_

No. \_\_\_\_\_ Dated: \_\_\_\_\_

No. \_\_\_\_\_ Dated: \_\_\_\_\_

The Bidder agrees to perform the base bid work described in the specifications and shown on the plans for the following lump sum or unit prices:

Item Number	Estimated Quantity	Brief Description Unit or Lump Sum Price Bid In Both Words and Figures	Total Figure
100.15	80	Gradall & Operator, per hour  at _____ dollars and  _____ cents (\$ _____)	\$ _____
120.1	750	Unclassified Excavation, per cubic yard  at _____ dollars and  _____ cents (\$ _____)	\$ _____
129.	50,000	Asphalt Pavement Excavation by Cold Planer, per square yard  at _____ dollars and  _____ cents (\$ _____)	\$ _____
129.2	1,000	Old Pavement Excavation, per square yard  at _____ dollars and  _____ cents (\$ _____)	\$ _____
156.	25	Crushed Stone, per ton  at _____ dollars and  _____ cents (\$ _____)	\$ _____
170.	1,000	Fine Grading and Compacting, per square yard  at _____ dollars and  _____ cents (\$ _____)	\$ _____
220.	175	Drainage Structure Adjusted, per each  at _____ dollars and  _____ cents (\$ _____)	\$ _____

Item Number	Estimated Quantity	Brief Description Unit or Lump Sum Price Bid In Both Words and Figures	Total Figure
220.2	10	Drainage Structure Rebuilt, per foot  at _____ dollars and  _____ cents (\$ _____)	\$ _____
220.5	30	Drainage Structure Remodeled, per each  at _____ dollars and  _____ cents (\$ _____)	\$ _____
220.6	10	Sanitary Structure Rebuilt, per foot  at _____ dollars and  _____ cents (\$ _____)	\$ _____
220.7	85	Sanitary Structure Adjusted, per each  at _____ dollars and  _____ cents (\$ _____)	\$ _____
220.8	45	Sanitary Structure Remodeled, per each  at _____ dollars and  _____ cents (\$ _____)	\$ _____
358.	50	Gate Box Adjusted, per each  at _____ dollars and  _____ cents (\$ _____)	\$ _____
381.3	25	Service Box Adjusted, per each  at _____ dollars and  _____ cents (\$ _____)	\$ _____

Item Number	Estimated Quantity	Brief Description Unit or Lump Sum Price Bid In Both Words and Figures	Total Figure
403.	28,000	Reclaimed Pavement for Base Course and/or Sub-base, per square yard  at _____ dollars and  _____ cents (\$ _____)	\$ _____
460.01	0	Asphalt Pavement – Marshall Mix, per ton  at _____ dollars and  _____ cents (\$ _____)	\$ _____
460.02	12,500	Asphalt Pavement – Superpave, per ton  at _____ dollars and  _____ cents (\$ _____)	\$ _____
464.	7,800	Bitumen for Tack Coat, per gallon  at _____ dollars and  _____ cents (\$ _____)	\$ _____
464.5	2,500	Hot Poured Rubberized Asphalt Sealer, per foot  At _____ dollars and  _____ cents (\$ _____)	\$ _____
470.2	3,500	Asphalt Berm, Type A-Modified, per foot  at _____ dollars and  _____ cents (\$ _____)	\$ _____
472.1	250	Asphalt for Miscellaneous Work, per ton  at _____ dollars and  _____ cents (\$ _____)	\$ _____



Item Number	Estimated Quantity	Brief Description Unit or Lump Sum Price Bid In Both Words and Figures	Total Figure
482.3	5,000	Sawing Asphalt Pavement, per foot  at _____ dollars and  _____ cents (\$ _____)	\$ _____
482.34	100	Sawing Cement Concrete, per foot  at _____ dollars and  _____ cents (\$ _____)	\$ _____
506.	500	Granite Curb Type VB – Straight, per foot  at _____ dollars and  _____ cents (\$ _____)	\$ _____
506.1	100	Granite Curb Type VB – Curved, per foot  at _____ dollars and  _____ cents (\$ _____)	\$ _____
509.	25	Granite Transition Curb for Wheelchair Ramps – Straight, per foot  at _____ dollars and  _____ cents (\$ _____)	\$ _____
509.1	150	Granite Transition Curb for Wheelchair Ramps – Curved, per foot  at _____ dollars and  _____ cents (\$ _____)	\$ _____
509.2	2	Sloped to Vertical Granite Transition Piece, per each  at _____ dollars and  _____ cents (\$ _____)	\$ _____

Item Number	Estimated Quantity	Brief Description Unit or Lump Sum Price Bid In Both Words and Figures	Total Figure
570.3	1,000	Asphalt Curb – Type 3, per foot  at _____ dollars and  _____ cents (\$ _____)	\$ _____
580.	250	Curb Removed and Reset, per foot  at _____ dollars and  _____ cents (\$ _____)	\$ _____
581.	2	Curb Inlet Removed and Reset, per each  at _____ dollars and  _____ cents (\$ _____)	\$ _____
590.	100	Curb Removed and Stacked, per foot  at _____ dollars and  _____ cents (\$ _____)	\$ _____
701.	500	Cement Concrete Sidewalk, per square yard  at _____ dollars and  _____ cents (\$ _____)	\$ _____
701.1	100	Cement Concrete Sidewalk at Driveways, per square yard  at _____ dollars and  _____ cents (\$ _____)	\$ _____
701.2	100	Cement Concrete Sidewalk at Wheelchair Ramps, per square yard  at _____ dollars and  _____ cents (\$ _____)	\$ _____

Item Number	Estimated Quantity	Brief Description Unit or Lump Sum Price Bid In Both Words and Figures	Total Figure
702.	750	Asphalt Walk Surface, per ton  at _____ dollars and  _____ cents (\$ _____)	\$ _____
703.	350	Asphalt Driveways, per ton  at _____ dollars and  _____ cents (\$ _____)	\$ _____
751.	500	Loam Borrow, per cubic yard  at _____ dollars and  _____ cents (\$ _____)	\$ _____
765.	3,500	Seeding, per square yard  at _____ dollars and  _____ cents (\$ _____)	\$ _____

Total Bid in Words \_\_\_\_\_

Total Bid in Figures \$ \_\_\_\_\_

Name of Bidder: \_\_\_\_\_

The above unit prices shall include all labor, materials, bailing, shoring, removal, overhead, profit, insurance, etc., to cover the finished work of the several kinds called for.

The Bidder understands that all bids for this project are subject to the applicable bidding laws of the Commonwealth of Massachusetts, including General Laws Chapter 30, Section 39M, as amended.

The Bidder understands that the Owner reserves the right to reject any or all bids and to waive any informalities in the bidding.

The Bidder agrees that this bid shall be good and may not be withdrawn for a period of 30 days, Saturdays, Sundays and legal holidays excluded, after the opening of bids.

Within 10 days of receipt of the written notice of acceptance of this bid, the Bidder will execute the formal Agreement attached in Section 00500 CONTRACT.

Bid security is attached in the sum of five percent (5%) of the total bid in accordance with the conditions of Section 00100 INSTRUCTIONS TO BIDDERS. The bid security may become the property of the Owner in the event the contract and bond are not executed within the time set forth above.

The selected Contractor shall furnish a performance bond and a payment bond in an amount at least equal to one hundred percent (100%) of the contract prices in accordance with Section 00610 PERFORMANCE BOND, Section 00620 PAYMENT BOND, and as stipulated in Section 00700 GENERAL CONDITIONS of these specifications.

The undersigned offers the following information as evidence of his qualifications to perform the work as bid upon according to all the requirements of the plans and specifications.

1. Have been in business under present name for \_\_\_\_ years.
2. The names and addresses of all persons interested in the bid (if made by a partnership or corporation) as Principals, are as follows:

---

---

---

---

---

---

(attach supplementary list if necessary)

3. The bidder is requested to state below what work of a similar character to that included in the proposed contract he has done and state below **ALL** work has been awarded and/or completed within the last 3 years, and give references that will enable the Owner to judge his experience, skill and business standing (add supplementary page(s) if necessary).

Completion    Project    Contract    Design    Reference    Telephone  
Date        Name        Amount    Engineer    Name        No.

a. \_\_\_\_\_  
\_\_\_\_\_

b. \_\_\_\_\_  
\_\_\_\_\_

c. \_\_\_\_\_  
\_\_\_\_\_

d. \_\_\_\_\_  
\_\_\_\_\_

e. \_\_\_\_\_  
\_\_\_\_\_

f. \_\_\_\_\_  
\_\_\_\_\_

4. Bank reference \_\_\_\_\_  
(Name)

\_\_\_\_\_ (Bank)

\_\_\_\_\_ (Address)

\_\_\_\_\_ (Telephone No.)

Pursuant to M.G.L. CH. 62C, Sec 49A, I certify under the penalties of perjury that I, to my best knowledge and belief, have filed all state tax returns and paid all State Taxes Required under law.

The undersigned Bidder hereby certifies that he is able to furnish labor that can work in harmony with all other elements of labor employed or to be employed in the work and that all employees to be employed at the worksite will have successfully completed a course in construction safety and health approved by the United States Occupational Safety and Health Administration that is at least 10 hours in duration at the time the employee begins work and who shall furnish documentation of successful completion of said course with the first certified payroll report for each employee.

The undersigned Bidder hereby certifies he/she will comply with the minority workforce percentage ratio and specific affirmative action steps contained in the EEO/AA provisions of this Contract, including compliance with the Minority/Woman Business Enterprise policy as required under these contract provisions. The contractor receiving the award of the contract shall be required to obtain from each of its subcontractors a copy of the certification by said subcontractor, regardless of tier, that it will comply with the minority workforce ratio and specific affirmative action steps contained in these EEO/AA contract provisions and submit it to the contracting agency prior to the award of such subcontract.

The undersigned certifies under penalties of perjury that this bid is in all respects bona fide, fair and made without collusion or fraud with any other person. As used in this paragraph the word "person" shall mean any natural person, joint venture, partnership, corporation or other business or legal entity.

Respectfully submitted:

Date: \_\_\_\_\_

By: \_\_\_\_\_  
(Signature)

(SEAL - if bid is by  
a corporation)

\_\_\_\_\_  
(Name of Bidder)

\_\_\_\_\_  
(Title)

\_\_\_\_\_  
(Business Address)

\_\_\_\_\_  
(City and State)

\_\_\_\_\_  
(Telephone Number)

SECTION 00500

AGREEMENT

THIS AGREEMENT, made this \_\_\_\_\_ day of \_\_\_\_\_,  
20\_\_\_\_, by and between the party of the first part, the Town of Dedham, hereinafter called  
"OWNER," acting herein through its Town Manager, and the party of the second part,  
\_\_\_\_\_ doing business as \*(an individual)  
(a partnership) (a joint venture) (a corporation) located in the \*  
(City) (Town) of \_\_\_\_\_, County of \_\_\_\_\_, and State of  
\_\_\_\_\_, hereinafter called "CONTRACTOR."

WITNESSETH: That for and in consideration of the payments and agreements  
hereinafter mentioned, to be made and performed by the OWNER, the CONTRACTOR hereby  
agrees with the OWNER to commence and complete the project described as follows:

CY2022 ASPHALT PAVING AND RESURFACING

hereinafter called the project, for the sum of

\_\_\_\_\_ Dollars

(\$ \_\_\_\_\_) and all extra work in connection therewith, under the terms as stated in  
the Contract Documents; and at his (its or their) own proper cost and expense to furnish all the  
materials, supplies, machinery equipment, tools, superintendence, labor, insurance, and other  
accessories and services necessary to complete the said project in accordance with the conditions  
and prices stated in Section 00300 FORM OF GENERAL BID, Section 00700 GENERAL  
CONDITIONS, and Section 00800 SUPPLEMENTAL GENERAL CONDITIONS, the plans,  
which include all maps, plates, blue prints, and the specifications and Contract Documents as  
prepared by the Owner.

\_\_\_\_\_  
\*Strike out inapplicable term.

The CONTRACTOR hereby agrees to commence work under this Contract on or before a date to be specified in written "Notice to Proceed" of the OWNER.

The CONTRACTOR further agrees to fully complete the project by December 31, 2022.

The CONTRACTOR further agrees to pay as liquidated damages the sum of \$1,000 for each consecutive calendar day thereafter as provided in the Liquidated Damages Paragraph of Section 00700 GENERAL CONDITIONS.

The CONTRACTOR agrees not to discriminate against or exclude any person from participation herein on grounds of race, religion, color, sex, age or national origin; and that it shall take affirmative actions to insure that applicants are employed, and that employees are treated during their employment, without regard to race, religion, color, sex, age, handicapped status, or national origin.

The CONTRACTOR agrees not to participate in or cooperate with an international boycott, as defined in Section 999 (b)(3) and (4) of the Internal Revenue Code of 1954, as amended, or engage in conduct declared to be unlawful by Section 2 of Chapter 151E of the Massachusetts General Laws.

The OWNER agrees to pay the CONTRACTOR in current funds for the performance of the contract, subject to additions and deductions, as provided in Section 00700 GENERAL CONDITIONS, and to make payments on account thereof as provided in the Estimates and Payments Paragraph of Section 00700 GENERAL CONDITIONS.

IN WITNESS WHEREOF, the parties to these presents have executed this contract in four (4) counterparts, each of which shall be deemed an original, in the year and day first above mentioned.



AGREED:

**TOWN OF DEDHAM, MASSACHUSETTS**  
(Owner)

By \_\_\_\_\_

\_\_\_\_\_  
(Name)

\_\_\_\_\_  
(Title)

**CONTRACTOR:** \_\_\_\_\_

By \_\_\_\_\_

\_\_\_\_\_  
(Name)

\_\_\_\_\_  
(Title)

\_\_\_\_\_  
(Address)

\_\_\_\_\_  
(City and State)

Approved as to Form:

By \_\_\_\_\_

(Owner's Counsel)

In accordance with M.G.L. C.44, Section 31C, this is to certify that an appropriation in the amount of this contract is available therefor and that the \_\_\_\_\_ has been authorized to execute the contract and approve all requisitions and change orders.

By \_\_\_\_\_

(Owner's Director of Finance or Accountant)

\_\_\_\_\_  
(Name)

CERTIFICATE OF VOTE  
(to be filed if Contractor is a Corporation)

I, \_\_\_\_\_, hereby certify that I am the duly qualified  
(Secretary of the Corporation)

and acting Secretary of \_\_\_\_\_ and I further certify that a meeting of the  
(Name of Corporation)

Directors of said Company, duly called and held on \_\_\_\_\_, at which  
(Date of Meeting)

all Directors were present and voting, the following vote was unanimously passed:

VOTED: To authorize and empower

\_\_\_\_\_

\_\_\_\_\_

\_\_\_\_\_

\_\_\_\_\_

\_\_\_\_\_

Anyone acting singly, to execute Forms of General Bid, Contracts or Bonds on behalf of the Corporation.

I further certify that the above vote is still in effect and has not been changed or modified in any respect.

By: \_\_\_\_\_  
(Secretary of Corporation)

A True Copy:

Attest: \_\_\_\_\_  
(Notary Public)

My Commission Expires: \_\_\_\_\_  
(Date)

Contractor's Certification

A Contractor will not be eligible for award of a contract unless such Contractor has submitted the following certification, which is deemed a part of the resulting contract:

CONTRACTOR'S CERTIFICATION

---

Name of the General Contractor

certifies that:

1. It intends to use the following listed construction trades in the work under the contract  
  

---

---
2. Will comply with the minority workforce ratio and specific affirmative action steps contained herein; and
3. Will obtain from each of its subcontractors and submit to the contracting or administering agency prior to the award of any subcontract under this contract the subcontractor's certification required by these bid conditions.
4. As evidenced by the signature of the Contractor's Authorized Signatory below, the Contractor certifies under the pains and penalties of perjury that the Contractor shall not knowingly use undocumented workers in connection with the performance of all Executive Branch contracts; that pursuant to federal requirements, the Contractor shall verify the immigration status of all workers assigned to such contracts without engaging in unlawful discrimination; and that the Contractor shall not knowingly or recklessly alter, falsify, or accept altered or falsified documents from any such worker(s). The Contractor understands and agrees that breach of any of these terms during the period of each contract may be regarded as a material breach, subjecting the Contractor to sanctions, including but not limited to monetary penalties, withholding of payments, contract suspension or termination.

---

Signature of Authorized  
Representative of Contractor

Subcontractor's Certification

Prior to the award of any subcontract, regardless of tier, the prospective subcontractor must execute and submit to the General Contractor the following certification, which will be deemed a part of the resulting subcontract:

SUBCONTRACTOR'S CERTIFICATION

---

Name of the Subcontractor

certifies that:

1. It intends to use the following listed construction trades in the work under contract  

---

---
2. Will comply with the minority workforce ratio and specific affirmative action steps contained herein; and
3. Will obtain from each of its subcontractors prior to the award of any subcontract under this contract the subcontractor's certification required by these bid conditions.

---

Signature of Authorized  
Representative of Subcontractor

SECTION 00610  
**PERFORMANCE BOND**

KNOW ALL MEN BY THESE PRESENTS: That we \_\_\_\_\_  
(Name of Contractor)

a \_\_\_\_\_ hereinafter called "Principal" and  
(Corporation, Partnership, Joint Venture or Individual)

\_\_\_\_\_ of \_\_\_\_\_, State of \_\_\_\_\_  
(Surety) (City)

hereinafter called the "Surety" and licensed by the State Division of Insurance to do business under the laws of the Commonwealth of Massachusetts, are held and firmly bound to the Town of Dedham, Massachusetts, hereinafter called "Owner", in the penal sum of \_\_\_\_\_ Dollars (\$ \_\_\_\_\_) in lawful money of the United States, for the payment of which sum well and truly to be made, we bind ourselves, our heirs, executors, administrators and successors, jointly and severally, firmly by these presents.

THE CONDITION OF THIS OBLIGATION is such that whereas the Principal has entered into a certain contract with the Owner (the "Construction Contract"), dated the \_\_\_\_\_ day of \_\_\_\_\_, 20\_\_\_\_, for the construction described as follows:

CY2022 ASPHALT PAVING AND RESURFACING.

NOW, THEREFORE, if the Principal shall well, truly and faithfully perform its duties, all the undertakings, covenants, terms, conditions, and agreements of the Construction Contract during the original term thereof, and any extensions thereof which may be granted by the Owner, with or without notice to the Surety, and if he shall satisfy all claims and demands incurred under the Construction Contract, and shall fully indemnify and save harmless the Owner from all costs and damages which it may suffer by reason of failure to do so, and shall reimburse and repay the Owner all outlay and expense which the Owner may incur in making good any default, then this obligation shall be void; otherwise, this obligation shall remain in full force and effect.

PROVIDED, FURTHER, that the Surety's obligation under this Bond shall arise after (1) the Owner has declared the Principal in default of the Construction Contract or (2) has declared that the Principal has failed, or is otherwise unable or unwilling, to execute the work consistent with, and in conformance to, the Construction Contract (collectively referred to as a "Contractor Default"). The determination of a Contractor Default shall be made solely by the Owner.

When the Surety's obligation under this Bond arises, the Surety, at its sole expense and at the consent and election of the Owner, shall immediately take one of following steps: (1) arrange for the Principal to perform and complete the work of the Construction Contract; (2) arrange for a contractor other than the Principal to perform and complete the work of the Construction

Contract; (3) reimburse the Owner, in a manner and at such time as the Owner shall decide, for all costs and expenses incurred by the Owner in performing and completing the work of the Construction Contract.

If the Surety does not proceed as provided in this Bond with due diligence and all deliberate speed, the Surety shall be deemed to be in default of this Bond, and the Owner shall be entitled to enforce any remedy available to the Owner.

After the Surety's obligation under this Bond arises, the Surety is obligated, to the limit of the amounts of this Bond, for (1) the correction of defective work and completion of the Construction Contract; (2) additional design, professional services, and legal costs, including attorney's fees, resulting from the Contractor Default or from the default of the Surety under this Bond; (3) any additional work beyond the Construction Contract made necessary by the Contractor Default or default of the Surety under this Bond; and (4) liquidated damages as provided in the Construction Contract, or if none are so specified, actual and foreseeable consequential damages resulting from the Contractor Default or default of the Surety under this Bond.

Any proceeding, legal or equitable, under this Bond shall be instituted in any court of competent jurisdiction in the Commonwealth of Massachusetts.

The Surety, for value received, hereby stipulates and agrees that no change, extension of time, alteration or addition to the terms of the Construction Contract or to the work to be performed thereunder or the specifications accompanying the same shall in any way affect its obligation on this bond, and it does hereby waive notice of any such change, extension of time, alteration or addition to the terms of the Construction Contract or to the work or to the specifications.

IN WITNESS WHEREOF, this instrument is executed in \_\_\_\_\_ ( ) counterparts, each one of which shall be deemed an original, this the \_\_\_\_\_ day of \_\_\_\_\_, 20\_\_.

ATTEST:

\_\_\_\_\_  
Principal

\_\_\_\_\_  
(Principal Secretary)

By \_\_\_\_\_  
\_\_\_\_\_  
\_\_\_\_\_

\_\_\_\_\_  
(Address-Zip Code)

\_\_\_\_\_ (SEAL)

Witness as to Principal

\_\_\_\_\_

\_\_\_\_\_

(Address-Zip Code)

ATTEST:

\_\_\_\_\_

By

\_\_\_\_\_

Surety

\_\_\_\_\_

(Attorney-in-Fact)

\_\_\_\_\_

\_\_\_\_\_

(Address-Zip Code)

\_\_\_\_\_

(SEAL)

Witness as to Surety

\_\_\_\_\_

\_\_\_\_\_

(Address-Zip Code)

NOTE: Date of Bond must not be prior to date of Contract. If Contractor is a Partnership, all partners should execute Bond.

SECTION 00620

PAYMENT BOND

KNOW ALL MEN BY THESE PRESENTS: That we \_\_\_\_\_

\_\_\_\_\_ a \_\_\_\_\_  
(Name of Contractor) (Corporation, Partnership, Joint Venture or Individual)

hereinafter called "Principal" and \_\_\_\_\_ of \_\_\_\_\_,  
(Surety)

State of \_\_\_\_\_ hereinafter called the "Surety" and licensed by the State  
(City and State)

Division of Insurance to do business under the laws of the Commonwealth of Massachusetts, are held and firmly bound to the Town of Dedham, Massachusetts, hereinafter called "Owner", in the penal sum of \_\_\_\_\_ Dollars (\$\_\_\_\_\_) in lawful money of the United States, for the payment of which sum well and truly to be made, we bind ourselves, our heirs, executors, administrators and successors, jointly and severally, firmly by these presents.

THE CONDITION OF THIS OBLIGATION is such that Whereas, the Principal entered into a certain contract with the Owner, dated the \_\_\_\_\_ day of \_\_\_\_\_, 20\_\_\_\_, a copy of which is hereto attached and made a part hereof for the construction described as follows:

CY2022 ASPHALT PAVING AND RESURFACING.

NOW, THEREFORE, if the Principal shall promptly make payment to all persons, firms, subcontractors, and corporations furnishing materials for or performing labor in the prosecution of the work provided for in such contract, and any authorized extension or modification thereof, including all amounts due for materials, lubricants, oil, gasoline, coal and coke, repairs on machinery, equipment and tools, consumed or used in connection with the construction of such work, and all insurance premiums on said work, and for all labor, performed in such work whether by subcontractor or otherwise, then this obligation shall be void; otherwise to remain in full force and effect.

PROVIDED, FURTHER, that the said Surety, for value received hereby stipulates and agrees that no change, extension of time, alteration or addition to the terms of the contract or to the work to be performed thereunder or the specifications accompanying the same shall in any way affect its obligation on this bond, and it does hereby waive notice of any such change, extension of time, alteration or addition to the terms of this contract or to the work or to the specifications.



PROVIDED, FURTHER, that no final settlement between the Owner and the Contractor shall abridge the right of any beneficiary hereunder, whose claim may be unsatisfied.

IN WITNESS WHEREOF, this instrument is executed in \_\_\_\_ ( ) counterparts, each one of which shall be deemed an original, this the \_\_\_\_\_ day of \_\_\_\_\_, 20\_\_.

ATTEST:

		_____
		Principal
_____	By	_____
(Principal Secretary)		_____
		_____
		_____
		(Address-Zip Code)

\_\_\_\_\_ (SEAL)  
 Witness as to Principal

\_\_\_\_\_

\_\_\_\_\_ (Address-Zip Code)

ATTEST:

		_____
		Surety
_____	By	_____
		(Attorney-in-Fact)
		_____
		_____
		(Address-Zip Code)

\_\_\_\_\_ (SEAL)  
 Witness as to Surety

\_\_\_\_\_

\_\_\_\_\_ (Address-Zip Code)

NOTE: Date of Bond must not be prior to date of Contract. If Contractor is a Partnership, all partners should execute Bond.

**SECTION 00650  
CERTIFICATE OF INSURANCE**

<b>Type of Insurance</b>	<b>Limit Requirements &amp; Notes</b>
General Liability	<p>\$1,000,000 Per Occurrence \$2,000,000 General Aggregate \$2,000,000 Products/Completed Operations Aggregate</p> <p>General Liability coverage must be maintained on an Occurrence basis, and must be amended to state that the Aggregate Limit applies on a Per Project basis. Explosion, collapse and underground property damage (XCU) hazards must be included. Town of Dedham shall be included as Additional Insured with respect to ongoing and completed operations via endorsements CG 2010 10/01 and CG 2037 10/01 or equivalent, and this policy shall be Primary and Non-Contributory with respect to any other insurance available to Additional Insureds. A Waiver of Subrogation shall be provided in favor of Town of Dedham.</p>
Auto Liability	<p>\$1,000,000 Combined Single Limit – Bodily Injury &amp; Property Damage</p> <p>Auto Liability coverage shall be afforded for all owned, non-owned and hired vehicles used in the performance of the work. Town of Dedham shall be included as Additional Insured, and this policy shall be Primary and Non-Contributory with respect to any other insurance available to Additional Insureds. A Waiver of Subrogation shall be provided in favor of Town of Dedham.</p>
Workers' Compensation & Employers' Liability	<p>Part I: Statutory Limits Part II: \$500,000 Each Accident           \$500,000 Disease Per Employee           \$500,000 Disease Policy Aggregate</p> <p>A Waiver of Subrogation shall be provided in favor of Town of Dedham.</p>
Umbrella/Excess Liability	<p>\$5,000,000 Per Occurrence \$5,000,000 Aggregate</p> <p>The Contractor shall provide Umbrella Liability coverage in a form at least as broad as primary coverages required in this Exhibit with respect to General Liability, Auto Liability and Employers' Liability. Additional Insured status shall be provided to Town of Dedham as provided by primary coverages. Waivers of Subrogation shall be provided in favor of Town of Dedham as provided by primary coverages. This policy shall be primary/non-contributory with respect to any other insurance available to Additional Insured(s).</p>
Pollution/Environmental Liability	<p>\$1,000,000 Each Claim \$1,000,000 Aggregate</p> <p>Additional Insured status shall be provided to Town of Dedham, and this policy shall be Primary and Non-Contributory with respect to any other insurance available to Additional Insured(s). A Waiver of Subrogation shall be provided in favor of Town of Dedham.</p>
Riggers' Liability	<p>Contractor and/or its subcontractor(s) shall carry Riggers Liability Insurance with limits no less than \$1,000,000 per occurrence if Contractor's Work involves moving, lifting, lowering, rigging or hoisting of property or equipment belonging to others. Such insurance shall insure against physical loss or damage to the property or equipment. Owner and Contractor shall be listed as additional insured on such policies.</p>
Additional Types of Insurance	<p>The Contractor shall provide such other types of insurance as may be required at Town of Dedham's discretion.</p>

CONTRACTUAL LIABILITY

To the fullest extent permitted by Laws and Regulations, CONTRACTOR shall indemnify, and hold harmless OWNER and its consultants, agents and employees from and against all claims, damages, losses and expenses, direct, indirect or consequential (including but not limited to fees and charges of engineers, architects, attorneys and other professionals and court and arbitration costs) arising out of or resulting from performance of the Work, provided that any such claim, damage, loss or expense(s) is attributable to bodily injury, sickness, disease or death, or to injury to or destruction of tangible property (other than the Work itself) including the loss of use resulting therefrom and (b) is caused in whole or in part by any negligent act or omission of CONTRACTOR, any subcontractor, any person or organization directly or indirectly employed by any of them to perform or furnish any of the Work or anyone for whose acts any of them may be liable, regardless of whether or not it is caused in part by a party indemnified hereunder or arises by or is imposed by Law and Regulations regardless of the negligence of any such party.

In any and all claims against OWNER or any of its consultants, agents or employees by any employee of CONTRACTOR, and subcontractor, any person or organization directly or indirectly employed by any of them to perform or furnish any of the Work or anyone for whose acts any of them may be liable, the indemnification obligation under the above paragraph shall not be limited in any way by any limitation on the amount or type of damages, compensation or benefits payable by or for CONTRACTOR or any such subcontractor or other person or organization under workers' or workmen's compensation acts, disability benefit acts or other employee benefits acts.

Policies B, C, D, and E shall remain in effect during the one year correction period.

Such insurance as is herein certified applies to all operations of the insured in connection with, and necessary and incidental to, the work herein described at the locations stated.

It is hereby understood and agreed that the above policies will not be restrictively amended, materially changed nor canceled without 30 days advance notice by registered mail to OWNER.

---

Authorized Representative Signature  
(Include Evidence of Authorization)

---

Address

SECTION 00700  
GENERAL CONDITIONS

**TABLE OF CONTENTS**

<u>Article 1 – Definitions and Terminology</u> .....	1
1.01 Defined Terms .....	1
1.02 Terminology.....	5
<u>Article 2 – Preliminary Matters</u> .....	7
2.01 Delivery of Bonds and Evidence of Insurance .....	7
2.02 Copies of Documents .....	7
2.03 Before Starting Construction .....	7
2.04 Preconstruction Conference; Designation of Authorized Representatives .....	8
2.05 Initial Acceptance of Schedules.....	8
2.06 Electronic Transmittals .....	8
<u>Article 3 – Documents: Intent, Requirements, Reuse</u> .....	9
3.01 Intent .....	9
3.02 Reference Standards.....	9
3.03 Reporting and Resolving Discrepancies .....	9
3.04 Requirements of the Contract Documents .....	10
3.05 Reuse of Documents .....	11
<u>Article 4 – Commencement and Progress of the Work</u> .....	11
4.01 Commencement of Contract Times; Notice to Proceed .....	11
4.02 Starting the Work.....	11
4.03 Reference Points .....	12
4.04 Progress Schedule .....	12
4.05 Delays in Contractor’s Progress.....	12
<u>Article 5 – Availability of Lands; Subsurface and Physical Conditions; Hazardous Environmental Conditions</u> .....	13
5.01 Availability of Lands .....	13
5.02 Use of Site and Other Areas.....	13
5.03 Subsurface and Physical Conditions.....	15
5.04 Differing Subsurface or Physical Conditions .....	15
5.05 Underground Facilities.....	17

5.06	Hazardous Environmental Conditions at Site .....	19
<u>Article 6 – Bonds and Insurance</u> .....		21
6.01	Performance, Payment, and Other Bonds .....	21
6.02	Insurance—General Provisions .....	22
6.03	Contractor’s Insurance .....	23
6.04	Owner’s Liability Insurance .....	25
6.05	Property Insurance .....	26
6.06	Waiver of Rights .....	28
6.07	Receipt and Application of Property Insurance Proceeds.....	29
<u>Article 7 – Contractor’s Responsibilities</u> .....		29
7.01	Supervision and Superintendence .....	29
7.02	Labor; Working Hours .....	30
7.03	Services, Materials, and Equipment.....	30
7.04	“Or Equals” .....	30
7.05	Substitutes .....	31
7.06	Concerning Subcontractors, Suppliers, and Others .....	33
7.07	Patent Fees and Royalties .....	35
7.08	Permits .....	35
7.09	Taxes .....	36
7.10	Laws and Regulations .....	36
7.11	Record Documents.....	36
7.12	Safety and Protection .....	37
7.13	Safety Representative.....	38
7.14	Hazard Communication Programs.....	38
7.15	Emergencies.....	38
7.16	Shop Drawings, Samples, and Other Submittals .....	38
7.17	Contractor’s General Warranty and Guarantee.....	41
7.18	Indemnification .....	41
7.19	Delegation of Professional Design Services .....	42
<u>Article 8 – Other Work at the Site</u> .....		42
8.01	Other Work .....	42
8.02	Coordination .....	42
8.03	Legal Relationships.....	42

<u>Article 9 – Owner’s Responsibilities</u> .....	45
9.01 Communications to Contractor .....	45
9.02 Replacement of Engineer .....	45
9.03 Furnish Data.....	45
9.04 Pay When Due .....	45
9.05 Lands and Easements; Reports, Tests, and Drawings.....	45
9.06 Insurance .....	46
9.07 Change Orders .....	46
9.08 Inspections, Tests, and Approvals .....	46
9.09 Limitations on Owner’s Responsibilities.....	46
9.10 Undisclosed Hazardous Environmental Condition.....	46
9.11 Evidence of Financial Arrangements.....	46
9.12 Safety Programs .....	46
<u>Article 10 – Engineer’s Status During Construction</u> .....	46
10.01 Owner’s Representative.....	46
10.02 Visits to Site.....	47
10.03 Project Representative .....	47
10.04 Rejecting Defective Work.....	47
10.05 Shop Drawings, Change Orders and Payments .....	47
10.06 Determinations for Unit Price Work.....	48
10.07 Decisions on Requirements of Contract Documents and Acceptability of Work ...	48
10.08 Limitations on Engineer’s Authority and Responsibilities.....	48
10.09 Compliance with Safety Program .....	48
<u>Article 11 – Amending the Contract Documents; Changes in the Work</u> .....	49
11.01 Amending and Supplementing Contract Documents.....	49
11.02 Owner-Authorized Changes in the Work .....	49
11.03 Unauthorized Changes in the Work.....	50
11.04 Change of Contract Price .....	50
11.05 Change of Contract Times .....	51
11.06 Change Proposals.....	51
11.07 Execution of Change Orders .....	52
11.08 Notification to Surety.....	53
<u>Article 12 – Claims</u> .....	53

12.01	Claims .....	53
<u>Article 13 – Cost of the Work; Allowances; Unit Price Work .....</u>		54
13.01	Cost of the Work .....	54
13.02	Allowances .....	57
13.03	Unit Price Work .....	58
<u>Article 14 – Tests and Inspections; Correction, Removal or Acceptance of Defective Work .....</u>		59
14.01	Access to Work .....	59
14.02	Tests, Inspections, and Approvals .....	59
14.03	Defective Work .....	60
14.04	Acceptance of Defective Work .....	60
14.05	Uncovering Work .....	61
14.06	Owner May Stop the Work .....	61
14.07	Owner May Correct Defective Work .....	61
<u>Article 15 – Payments to Contractor; Set-Offs; Completion; Correction Period .....</u>		62
15.01	Progress Payments .....	62
15.02	Contractor’s Warranty of Title .....	66
15.03	Substantial Completion .....	66
15.04	Partial Use or Occupancy .....	67
15.05	Final Inspection .....	67
15.06	Final Payment .....	68
15.07	Waiver of Claims .....	69
15.08	Correction Period .....	69
<u>Article 16 – Suspension of Work and Termination .....</u>		70
16.01	Owner May Suspend Work .....	70
16.02	Owner May Terminate for Cause .....	70
16.03	Owner May Terminate For Convenience .....	72
16.04	Contractor May Stop Work or Terminate .....	72
<u>Article 17 – Final Resolution of Disputes .....</u>		73
17.01	Methods and Procedures .....	73
<u>Article 18 – Miscellaneous .....</u>		73
18.01	Giving Notice .....	73
18.02	Computation of Times .....	73
18.03	Cumulative Remedies .....	73

18.04	Limitation of Damages .....	74
18.05	No Waiver.....	74
18.06	Survival of Obligations .....	74
18.07	Controlling Law .....	74
18.08	Headings.....	74



SECTION 00700

**GENERAL CONDITIONS OF THE CONTRACT FOR CONSTRUCTION**

**ARTICLE 1 – DEFINITIONS AND TERMINOLOGY**

1.01 *Defined Terms*

- A. Wherever used in the Bidding Requirements or Contract Documents, a term printed with initial capital letters, including the term's singular and plural forms, will have the meaning indicated in the definitions below. In addition to terms specifically defined, terms with initial capital letters in the Contract Documents include references to identified articles and paragraphs, and the titles of other documents or forms.
1. *Addenda*—Written or graphic instruments issued prior to the opening of Bids which clarify, correct, or change the Bidding Requirements or the proposed Contract Documents.
  2. *Agreement*—The written instrument, executed by Owner and Contractor, that sets forth the Contract Price and Contract Times, identifies the parties and the Engineer, and designates the specific items that are Contract Documents.
  3. *Application for Payment*—The form acceptable to Engineer which is to be used by Contractor during the course of the Work in requesting progress or final payments and which is to be accompanied by such supporting documentation as is required by the Contract Documents.
  4. *Bid*—The offer of a Bidder submitted on the prescribed form setting forth the prices for the Work to be performed.
  5. *Bidder*—An individual or entity that submits a Bid to Owner.
  6. *Bidding Documents*—The Bidding Requirements, the proposed Contract Documents, and all Addenda.
  7. *Bidding Requirements*—The advertisement or invitation to bid, Instructions to Bidders, Bid Bond or other Bid security, if any, the Bid Form, and the Bid with any attachments.
  8. *Change Order*—A document which is signed by Contractor and Owner and authorizes an addition, deletion, or revision in the Work or an adjustment in the Contract Price or the Contract Times, or other revision to the Contract, issued on or after the Effective Date of the Contract.
  9. *Change Proposal*—A written request by Contractor, duly submitted in compliance with the procedural requirements set forth herein, seeking an adjustment in Contract Price or Contract Times, or both; contesting an initial decision by Engineer concerning the requirements of the Contract Documents or the acceptability of Work under the Contract Documents; challenging a set-off

against payments due; or seeking other relief with respect to the terms of the Contract.

10. *Claim*—(a) A demand or assertion by Owner directly to Contractor, duly submitted in compliance with the procedural requirements set forth herein: seeking an adjustment of Contract Price or Contract Times, or both; contesting an initial decision by Engineer concerning the requirements of the Contract Documents or the acceptability of Work under the Contract Documents; contesting Engineer’s decision regarding a Change Proposal; seeking resolution of a contractual issue that Engineer has declined to address; or seeking other relief with respect to the terms of the Contract; or (b) a demand or assertion by Contractor directly to Owner, duly submitted in compliance with the procedural requirements set forth herein, contesting Engineer’s decision regarding a Change Proposal; or seeking resolution of a contractual issue that Engineer has declined to address. A demand for money or services by a third party is not a Claim.
11. *Constituent of Concern*—Asbestos, petroleum, radioactive materials, polychlorinated biphenyls (PCBs), hazardous waste, and any substance, product, waste, or other material of any nature whatsoever that is or becomes listed, regulated, or addressed pursuant to (a) the Comprehensive Environmental Response, Compensation and Liability Act, 42 U.S.C. §§9601 et seq. (“CERCLA”); (b) the Hazardous Materials Transportation Act, 49 U.S.C. §§5101 et seq.; (c) the Resource Conservation and Recovery Act, 42 U.S.C. §§6901 et seq. (“RCRA”); (d) the Toxic Substances Control Act, 15 U.S.C. §§2601 et seq.; (e) the Clean Water Act, 33 U.S.C. §§1251 et seq.; (f) the Clean Air Act, 42 U.S.C. §§7401 et seq.; or (g) any other federal, state, or local statute, law, rule, regulation, ordinance, resolution, code, order, or decree regulating, relating to, or imposing liability or standards of conduct concerning, any hazardous, toxic, or dangerous waste, substance, or material.
12. *Contract*—The entire and integrated written contract between the Owner and Contractor concerning the Work.
13. *Contract Documents*—Those items so designated in the Agreement, and which together comprise the Contract.
14. *Contract Price*—The money that Owner has agreed to pay Contractor for completion of the Work in accordance with the Contract Documents. .
15. *Contract Times*—The number of days or the dates by which Contractor shall: (a) achieve Milestones, if any; (b) achieve Substantial Completion; and (c) complete the Work.
16. *Contractor*—The individual or entity with which Owner has contracted for performance of the Work.
17. *Cost of the Work*—See Paragraph 13.01 for definition.
18. *Drawings*—The part of the Contract that graphically shows the scope, extent, and character of the Work to be performed by Contractor.

19. *Effective Date of the Contract*—The date, indicated in the Agreement, on which the Contract becomes effective.
20. *Engineer*—The individual or entity named as such in the Agreement.
21. *Field Order*—A written order issued by Engineer which requires minor changes in the Work but does not change the Contract Price or the Contract Times.
22. *Hazardous Environmental Condition*—The presence at the Site of Constituents of Concern in such quantities or circumstances that may present a danger to persons or property exposed thereto. The presence at the Site of materials that are necessary for the execution of the Work, or that are to be incorporated in the Work, and that are controlled and contained pursuant to industry practices, Laws and Regulations, and the requirements of the Contract, does not establish a Hazardous Environmental Condition.
23. *Laws and Regulations; Laws or Regulations*—Any and all applicable laws, statutes, rules, regulations, ordinances, codes, and orders of any and all governmental bodies, agencies, authorities, and courts having jurisdiction.
24. *Liens*—Charges, security interests, or encumbrances upon Contract-related funds, real property, or personal property.
25. *Milestone*—A principal event in the performance of the Work that the Contract requires Contractor to achieve by an intermediate completion date or by a time prior to Substantial Completion of all the Work.
26. *Notice of Award*—The written notice by Owner to a Bidder of Owner's acceptance of the Bid.
27. *Notice to Proceed*—A written notice by Owner to Contractor fixing the date on which the Contract Times will commence to run and on which Contractor shall start to perform the Work.
28. *Owner*—The individual or entity with which Contractor has contracted regarding the Work, and which has agreed to pay Contractor for the performance of the Work, pursuant to the terms of the Contract.
29. *Progress Schedule*—A schedule, prepared and maintained by Contractor, describing the sequence and duration of the activities comprising the Contractor's plan to accomplish the Work within the Contract Times.
30. *Project*—The total undertaking to be accomplished for Owner by engineers, contractors, and others, including planning, study, design, construction, testing, commissioning, and start-up, and of which the Work to be performed under the Contract Documents is a part.
31. *Project Manual*—The written documents prepared for, or made available for, procuring and constructing the Work, including but not limited to the Bidding Documents or other construction procurement documents, geotechnical and existing conditions information, the Agreement, bond forms, General Conditions, Supplementary Conditions, and Specifications. The contents of the Project Manual may be bound in one or more volumes.

32. *Resident Project Representative*—The authorized representative of Engineer assigned to assist Engineer at the Site. As used herein, the term Resident Project Representative or “RPR” includes any assistants or field staff of Resident Project Representative.
33. *Samples*—Physical examples of materials, equipment, or workmanship that are representative of some portion of the Work and that establish the standards by which such portion of the Work will be judged.
34. *Schedule of Submittals*—A schedule, prepared and maintained by Contractor, of required submittals and the time requirements for Engineer’s review of the submittals and the performance of related construction activities.
35. *Schedule of Values*—A schedule, prepared and maintained by Contractor, allocating portions of the Contract Price to various portions of the Work and used as the basis for reviewing Contractor’s Applications for Payment.
36. *Shop Drawings*—All drawings, diagrams, illustrations, schedules, and other data or information that are specifically prepared or assembled by or for Contractor and submitted by Contractor to illustrate some portion of the Work. Shop Drawings, whether approved or not, are not Drawings and are not Contract Documents.
37. *Site*—Lands or areas indicated in the Contract Documents as being furnished by Owner upon which the Work is to be performed, including rights-of-way and easements, and such other lands furnished by Owner which are designated for the use of Contractor.
38. *Specifications*—The part of the Contract that consists of written requirements for materials, equipment, systems, standards, and workmanship as applied to the Work, and certain administrative requirements and procedural matters applicable to the Work.
39. *Subcontractor*—An individual or entity having a direct contract with Contractor or with any other Subcontractor for the performance of a part of the Work.
40. *Substantial Completion*—The time at which the Work (or a specified part thereof) has progressed to the point where, in the opinion of Engineer, the Work (or a specified part thereof) is sufficiently complete, in accordance with the Contract Documents, so that the Work (or a specified part thereof) can be utilized for the purposes for which it is intended. The terms “substantially complete” and “substantially completed” as applied to all or part of the Work refer to Substantial Completion thereof.
41. *Successful Bidder*—The Bidder whose Bid the Owner accepts, and to which the Owner makes an award of contract, subject to stated conditions.
42. *Supplementary Conditions*—The part of the Contract that amends or supplements these General Conditions.
43. *Supplier*—A manufacturer, fabricator, supplier, distributor, materialman, or vendor having a direct contract with Contractor or with any Subcontractor to

furnish materials or equipment to be incorporated in the Work by Contractor or a Subcontractor.

44. *Technical Data*—Those items expressly identified as Technical Data in the Supplementary Conditions, with respect to either (a) subsurface conditions at the Site, or physical conditions relating to existing surface or subsurface structures at the Site (except Underground Facilities) or (b) Hazardous Environmental Conditions at the Site. If no such express identifications of Technical Data have been made with respect to conditions at the Site, then the data contained in boring logs, recorded measurements of subsurface water levels, laboratory test results, and other factual, objective information regarding conditions at the Site that are set forth in any geotechnical or environmental report prepared for the Project and made available to Contractor are hereby defined as Technical Data with respect to conditions at the Site under Paragraphs 5.03, 5.04, and 5.06.
45. *Underground Facilities*—All underground pipelines, conduits, ducts, cables, wires, manholes, vaults, tanks, tunnels, or other such facilities or attachments, and any encasements containing such facilities, including but not limited to those that convey electricity, gases, steam, liquid petroleum products, telephone or other communications, fiber optic transmissions, cable television, water, wastewater, storm water, other liquids or chemicals, or traffic or other control systems.
46. *Unit Price Work*—Work to be paid for on the basis of unit prices.
47. *Work*—The entire construction or the various separately identifiable parts thereof required to be provided under the Contract Documents. Work includes and is the result of performing or providing all labor, services, and documentation necessary to produce such construction; furnishing, installing, and incorporating all materials and equipment into such construction; and may include related services such as testing, start-up, and commissioning, all as required by the Contract Documents.
48. *Work Change Directive*—A written directive to Contractor issued on or after the Effective Date of the Contract, signed by Owner and recommended by Engineer, ordering an addition, deletion, or revision in the Work.

## 1.02 Terminology

- A. The words and terms discussed in the following paragraphs are not defined but, when used in the Bidding Requirements or Contract Documents, have the indicated meaning.
- B. *Intent of Certain Terms or Adjectives:*
  1. The Contract Documents include the terms “as allowed,” “as approved,” “as ordered,” “as directed” or terms of like effect or import to authorize an exercise of professional judgment by Engineer. In addition, the adjectives “reasonable,” “suitable,” “acceptable,” “proper,” “satisfactory,” or adjectives of like effect or import are used to describe an action or determination of Engineer as to the Work. It is intended that such exercise of professional judgment, action, or determination will be solely to evaluate, in general, the Work for compliance

with the information in the Contract Documents and with the design concept of the Project as a functioning whole as shown or indicated in the Contract Documents (unless there is a specific statement indicating otherwise). The use of any such term or adjective is not intended to and shall not be effective to assign to Engineer any duty or authority to supervise or direct the performance of the Work, or any duty or authority to undertake responsibility contrary to the provisions of Article 10 or any other provision of the Contract Documents.

C. *Day:*

1. The word “day” means a calendar day of 24 hours measured from midnight to the next midnight.

D. *Defective:*

1. The word “defective,” when modifying the word “Work,” refers to Work that is unsatisfactory, faulty, or deficient in that it:
  - a. does not conform to the Contract Documents; or
  - b. does not meet the requirements of any applicable inspection, reference standard, test, or approval referred to in the Contract Documents; or
  - c. has been damaged prior to Engineer’s recommendation of final payment (unless responsibility for the protection thereof has been assumed by Owner at Substantial Completion in accordance with Paragraph 15.03 or 15.04).

E. *Furnish, Install, Perform, Provide:*

1. The word “furnish,” when used in connection with services, materials, or equipment, shall mean to supply and deliver said services, materials, or equipment to the Site (or some other specified location) ready for use or installation and in usable or operable condition.
2. The word “install,” when used in connection with services, materials, or equipment, shall mean to put into use or place in final position said services, materials, or equipment complete and ready for intended use.
3. The words “perform” or “provide,” when used in connection with services, materials, or equipment, shall mean to furnish and install said services, materials, or equipment complete and ready for intended use.
4. If the Contract Documents establish an obligation of Contractor with respect to specific services, materials, or equipment, but do not expressly use any of the four words “furnish,” “install,” “perform,” or “provide,” then Contractor shall furnish and install said services, materials, or equipment complete and ready for intended use.

- F. Unless stated otherwise in the Contract Documents, words or phrases that have a well-known technical or construction industry or trade meaning are used in the Contract Documents in accordance with such recognized meaning.

## ARTICLE 2 – PRELIMINARY MATTERS

### 2.01 *Delivery of Bonds and Evidence of Insurance*

- A. *Bonds*: When Contractor delivers the executed counterparts of the Agreement to Owner, Contractor shall also deliver to Owner such bonds as Contractor may be required to furnish.
- B. *Evidence of Contractor's Insurance*: When Contractor delivers the executed counterparts of the Agreement to Owner, Contractor shall also deliver to Owner, with copies to each named insured and additional insured (as identified in the Supplementary Conditions or elsewhere in the Contract), the certificates and other evidence of insurance required to be provided by Contractor in accordance with Article 6.
- C. *Evidence of Owner's Insurance*: After receipt of the executed counterparts of the Agreement and all required bonds and insurance documentation, Owner shall promptly deliver to Contractor, with copies to each named insured and additional insured (as identified in the Supplementary Conditions or otherwise), the certificates and other evidence of insurance required to be provided by Owner under Article 6.

### 2.02 *Copies of Documents*

- A. Owner shall furnish to Contractor four printed copies of the Contract (including one fully executed counterpart of the Agreement), and one copy in electronic portable document format (PDF). Additional printed copies will be furnished upon request at the cost of reproduction.
- B. Owner shall maintain and safeguard at least one original printed record version of the Contract, including Drawings and Specifications signed and sealed by Engineer and other design professionals. Owner shall make such original printed record version of the Contract available to Contractor for review. Owner may delegate the responsibilities under this provision to Engineer.

### 2.03 *Before Starting Construction*

- A. *Preliminary Schedules*: Within 10 days after the Effective Date of the Contract (or as otherwise specifically required by the Contract Documents), Contractor shall submit to Engineer for timely review:
  - 1. a preliminary Progress Schedule indicating the times (numbers of days or dates) for starting and completing the various stages of the Work, including any Milestones specified in the Contract;
  - 2. a preliminary Schedule of Submittals; and
  - 3. a preliminary Schedule of Values for all of the Work which includes quantities and prices of items which when added together equal the Contract Price and subdivides the Work into component parts in sufficient detail to serve as the basis for progress payments during performance of the Work. Such prices will include an appropriate amount of overhead and profit applicable to each item of Work.

2.04 *Preconstruction Conference; Designation of Authorized Representatives*

- A. Before any Work at the Site is started, a conference attended by Owner, Contractor, Engineer, and others as appropriate will be held to establish a working understanding among the parties as to the Work and to discuss the schedules referred to in Paragraph 2.03.A, procedures for handling Shop Drawings, Samples, and other submittals, processing Applications for Payment, electronic or digital transmittals, and maintaining required records.
- B. At this conference Owner and Contractor each shall designate, in writing, a specific individual to act as its authorized representative with respect to the services and responsibilities under the Contract. Such individuals shall have the authority to transmit and receive information, render decisions relative to the Contract, and otherwise act on behalf of each respective party.

2.05 *Initial Acceptance of Schedules*

- A. At least 10 days before submission of the first Application for Payment a conference, attended by Contractor, Engineer, and others as appropriate, will be held to review for acceptability to Engineer as provided below the schedules submitted in accordance with Paragraph 2.03.A. Contractor shall have an additional 10 days to make corrections and adjustments and to complete and resubmit the schedules. No progress payment shall be made to Contractor until acceptable schedules are submitted to Engineer.
  - 1. The Progress Schedule will be acceptable to Engineer if it provides an orderly progression of the Work to completion within the Contract Times. Such acceptance will not impose on Engineer responsibility for the Progress Schedule, for sequencing, scheduling, or progress of the Work, nor interfere with or relieve Contractor from Contractor's full responsibility therefor.
  - 2. Contractor's Schedule of Submittals will be acceptable to Engineer if it provides a workable arrangement for reviewing and processing the required submittals.
  - 3. Contractor's Schedule of Values will be acceptable to Engineer as to form and substance if it provides a reasonable allocation of the Contract Price to the component parts of the Work.

2.06 *Electronic Transmittals*

- A. Except as otherwise stated elsewhere in the Contract, the Owner, Engineer, and Contractor may transmit, and shall accept, Project-related correspondence, text, data, documents, drawings, information, and graphics, including but not limited to Shop Drawings and other submittals, in electronic media or digital format, either directly, or through access to a secure Project website.
- B. If the Contract does not establish protocols for electronic or digital transmittals, then Owner, Engineer, and Contractor shall jointly develop such protocols.
- C. When transmitting items in electronic media or digital format, the transmitting party makes no representations as to long term compatibility, usability, or readability of the items resulting from the recipient's use of software application packages,



operating systems, or computer hardware differing from those used in the drafting or transmittal of the items, or from those established in applicable transmittal protocols.

### **ARTICLE 3 – DOCUMENTS: INTENT, REQUIREMENTS, REUSE**

#### **3.01 *Intent***

- A. The Contract Documents are complementary; what is required by one is as binding as if required by all.
- B. It is the intent of the Contract Documents to describe a functionally complete project (or part thereof) to be constructed in accordance with the Contract Documents.
- C. Unless otherwise stated in the Contract Documents, if there is a discrepancy between the electronic or digital versions of the Contract Documents (including any printed copies derived from such electronic or digital versions) and the printed record version, the printed record version shall govern.
- D. The Contract supersedes prior negotiations, representations, and agreements, whether written or oral.
- E. Engineer will issue clarifications and interpretations of the Contract Documents as provided herein.

#### **3.02 *Reference Standards***

- A. Standards Specifications, Codes, Laws and Regulations
  - 1. Reference in the Contract Documents to standard specifications, manuals, reference standards, or codes of any technical society, organization, or association, or to Laws or Regulations, whether such reference be specific or by implication, shall mean the standard specification, manual, reference standard, code, or Laws or Regulations in effect at the time of opening of Bids (or on the Effective Date of the Contract if there were no Bids), except as may be otherwise specifically stated in the Contract Documents.
  - 2. No provision of any such standard specification, manual, reference standard, or code, or any instruction of a Supplier, shall be effective to change the duties or responsibilities of Owner, Contractor, or Engineer, or any of their subcontractors, consultants, agents, or employees, from those set forth in the part of the Contract Documents prepared by or for Engineer. No such provision or instruction shall be effective to assign to Owner, Engineer, or any of their officers, directors, members, partners, employees, agents, consultants, or subcontractors, any duty or authority to supervise or direct the performance of the Work or any duty or authority to undertake responsibility inconsistent with the provisions of the part of the Contract Documents prepared by or for Engineer.

#### **3.03 *Reporting and Resolving Discrepancies***

- A. *Reporting Discrepancies:*
  - 1. *Contractor's Verification of Figures and Field Measurements:* Before undertaking each part of the Work, Contractor shall carefully study the Contract

Documents, and check and verify pertinent figures and dimensions therein, particularly with respect to applicable field measurements. Contractor shall promptly report in writing to Engineer any conflict, error, ambiguity, or discrepancy that Contractor discovers, or has actual knowledge of, and shall not proceed with any Work affected thereby until the conflict, error, ambiguity, or discrepancy is resolved, by a clarification or interpretation by Engineer, or by an amendment or supplement to the Contract Documents issued pursuant to Paragraph 11.01.

2. *Contractor's Review of Contract Documents:* If, before or during the performance of the Work, Contractor discovers any conflict, error, ambiguity, or discrepancy within the Contract Documents, or between the Contract Documents and (a) any applicable Law or Regulation, (b) actual field conditions, (c) any standard specification, manual, reference standard, or code, or (d) any instruction of any Supplier, then Contractor shall promptly report it to Engineer in writing. Contractor shall not proceed with the Work affected thereby (except in an emergency as required by Paragraph 7.15) until the conflict, error, ambiguity, or discrepancy is resolved, by a clarification or interpretation by Engineer, or by an amendment or supplement to the Contract Documents issued pursuant to Paragraph 11.01.
3. Contractor shall not be liable to Owner or Engineer for failure to report any conflict, error, ambiguity, or discrepancy in the Contract Documents unless Contractor had actual knowledge thereof.

B. *Resolving Discrepancies:*

1. Except as may be otherwise specifically stated in the Contract Documents, the provisions of the part of the Contract Documents prepared by or for Engineer shall take precedence in resolving any conflict, error, ambiguity, or discrepancy between such provisions of the Contract Documents and:
  - a. the provisions of any standard specification, manual, reference standard, or code, or the instruction of any Supplier (whether or not specifically incorporated by reference as a Contract Document); or
  - b. the provisions of any Laws or Regulations applicable to the performance of the Work (unless such an interpretation of the provisions of the Contract Documents would result in violation of such Law or Regulation).

3.04 *Requirements of the Contract Documents*

- A. During the performance of the Work and until final payment, Contractor and Owner shall submit to the Engineer all matters in question concerning the requirements of the Contract Documents (sometimes referred to as requests for information or interpretation—RFIs), or relating to the acceptability of the Work under the Contract Documents, as soon as possible after such matters arise. Engineer will be the initial interpreter of the requirements of the Contract Documents, and judge of the acceptability of the Work thereunder.
- B. Engineer will, with reasonable promptness, render a written clarification, interpretation, or decision on the issue submitted, or initiate an amendment or

supplement to the Contract Documents. Engineer's written clarification, interpretation, or decision will be final and binding on Contractor, unless it appeals by submitting a Change Proposal, and on Owner, unless it appeals by filing a Claim.

- C. If a submitted matter in question concerns terms and conditions of the Contract Documents that do not involve (1) the performance or acceptability of the Work under the Contract Documents, (2) the design (as set forth in the Drawings, Specifications, or otherwise), or (3) other engineering or technical matters, then Engineer will promptly give written notice to Owner and Contractor that Engineer is unable to provide a decision or interpretation. If Owner and Contractor are unable to agree on resolution of such a matter in question, either party may pursue resolution as provided in Article 12.

### 3.05 *Reuse of Documents*

A. Contractor and its Subcontractors and Suppliers shall not:

1. have or acquire any title to or ownership rights in any of the Drawings, Specifications, or other documents (or copies of any thereof) prepared by or bearing the seal of Engineer or its consultants, including electronic media editions, or reuse any such Drawings, Specifications, other documents, or copies thereof on extensions of the Project or any other project without written consent of Owner and Engineer and specific written verification or adaptation by Engineer; or
2. have or acquire any title or ownership rights in any other Contract Documents, reuse any such Contract Documents for any purpose without Owner's express written consent, or violate any copyrights pertaining to such Contract Documents.

B. The prohibitions of this Paragraph 3.05 will survive final payment, or termination of the Contract. Nothing herein shall preclude Contractor from retaining copies of the Contract Documents for record purposes.

## **ARTICLE 4 – COMMENCEMENT AND PROGRESS OF THE WORK**

### 4.01 *Commencement of Contract Times; Notice to Proceed*

A. The Contract Times will commence to run on the thirtieth day after the Effective Date of the Contract or, if a Notice to Proceed is given, on the day indicated in the Notice to Proceed. A Notice to Proceed may be given at any time within 30 days after the Effective Date of the Contract. In no event will the Contract Times commence to run later than the sixtieth day after the day of Bid opening or the thirtieth day after the Effective Date of the Contract, whichever date is earlier.

### 4.02 *Starting the Work*

A. Contractor shall start to perform the Work on the date when the Contract Times commence to run. No Work shall be done at the Site prior to such date.

#### 4.03 *Reference Points*

- A. Owner shall provide engineering surveys to establish reference points for construction which in Engineer's judgment are necessary to enable Contractor to proceed with the Work. Contractor shall be responsible for laying out the Work, shall protect and preserve the established reference points and property monuments, and shall make no changes or relocations without the prior written approval of Owner. Contractor shall report to Engineer whenever any reference point or property monument is lost or destroyed or requires relocation because of necessary changes in grades or locations, and shall be responsible for the accurate replacement or relocation of such reference points or property monuments by professionally qualified personnel.

#### 4.04 *Progress Schedule*

- A. Contractor shall adhere to the Progress Schedule established in accordance with Paragraph 2.05 as it may be adjusted from time to time as provided below.
  - 1. Contractor shall submit to Engineer for acceptance (to the extent indicated in Paragraph 2.05) proposed adjustments in the Progress Schedule that will not result in changing the Contract Times.
  - 2. Proposed adjustments in the Progress Schedule that will change the Contract Times shall be submitted in accordance with the requirements of Article 11.
- B. Contractor shall carry on the Work and adhere to the Progress Schedule during all disputes or disagreements with Owner. No Work shall be delayed or postponed pending resolution of any disputes or disagreements, or during any appeal process, except as permitted by Paragraph 16.04, or as Owner and Contractor may otherwise agree in writing.

#### 4.05 *Delays in Contractor's Progress*

- A. If Owner, Engineer, or anyone for whom Owner is responsible, delays, disrupts, or interferes with the performance or progress of the Work, then Contractor shall be entitled to an equitable adjustment in the Contract Times and Contract Price. Contractor's entitlement to an adjustment of the Contract Times is conditioned on such adjustment being essential to Contractor's ability to complete the Work within the Contract Times.
- B. Contractor shall not be entitled to an adjustment in Contract Price or Contract Times for delay, disruption, or interference caused by or within the control of Contractor. Delay, disruption, and interference attributable to and within the control of a Subcontractor or Supplier shall be deemed to be within the control of Contractor.
- C. If Contractor's performance or progress is delayed, disrupted, or interfered with by unanticipated causes not the fault of and beyond the control of Owner, Contractor, and those for which they are responsible, then Contractor shall be entitled to an equitable adjustment in Contract Times. Contractor's entitlement to an adjustment of the Contract Times is conditioned on such adjustment being essential to Contractor's ability to complete the Work within the Contract Times. Such an adjustment shall be Contractor's sole and exclusive remedy for the delays, disruption, and interference

described in this paragraph. Causes of delay, disruption, or interference that may give rise to an adjustment in Contract Times under this paragraph include but are not limited to the following:

1. severe and unavoidable natural catastrophes such as fires, floods, epidemics, and earthquakes;
  2. abnormal weather conditions;
  3. acts or failures to act of utility owners (other than those performing other work at or adjacent to the Site by arrangement with the Owner, as contemplated in Article 8); and
  4. acts of war or terrorism.
- D. Delays, disruption, and interference to the performance or progress of the Work resulting from the existence of a differing subsurface or physical condition, an Underground Facility that was not shown or indicated by the Contract Documents, or not shown or indicated with reasonable accuracy, and those resulting from Hazardous Environmental Conditions, are governed by Article 5.
- E. Paragraph 8.03 governs delays, disruption, and interference to the performance or progress of the Work resulting from the performance of certain other work at or adjacent to the Site.
- F. Contractor shall not be entitled to an adjustment in Contract Price or Contract Times for any delay, disruption, or interference if such delay is concurrent with a delay, disruption, or interference caused by or within the control of Contractor.
- G. Contractor must submit any Change Proposal seeking an adjustment in Contract Price or Contract Times under this paragraph within 30 days of the commencement of the delaying, disrupting, or interfering event.

## **ARTICLE 5 – AVAILABILITY OF LANDS; SUBSURFACE AND PHYSICAL CONDITIONS; HAZARDOUS ENVIRONMENTAL CONDITIONS**

### *5.01 Availability of Lands*

- A. Owner shall furnish the Site. Owner shall notify Contractor of any encumbrances or restrictions not of general application but specifically related to use of the Site with which Contractor must comply in performing the Work.
- B. Upon reasonable written request, Owner shall furnish Contractor with a current statement of record legal title and legal description of the lands upon which permanent improvements are to be made and Owner's interest therein as necessary for giving notice of or filing a mechanic's or construction lien against such lands in accordance with applicable Laws and Regulations.
- C. Contractor shall provide for all additional lands and access thereto that may be required for temporary construction facilities or storage of materials and equipment.

## 5.02 *Use of Site and Other Areas*

### A. *Limitation on Use of Site and Other Areas:*

1. Contractor shall confine construction equipment, temporary construction facilities, the storage of materials and equipment, and the operations of workers to the Site, adjacent areas that Contractor has arranged to use through construction easements or otherwise, and other adjacent areas permitted by Laws and Regulations, and shall not unreasonably encumber the Site and such other adjacent areas with construction equipment or other materials or equipment. Contractor shall assume full responsibility for (a) damage to the Site; (b) damage to any such other adjacent areas used for Contractor's operations; (c) damage to any other adjacent land or areas; and (d) for injuries and losses sustained by the owners or occupants of any such land or areas; provided that such damage or injuries result from the performance of the Work or from other actions or conduct of the Contractor or those for which Contractor is responsible.
  2. If a damage or injury claim is made by the owner or occupant of any such land or area because of the performance of the Work, or because of other actions or conduct of the Contractor or those for which Contractor is responsible, Contractor shall (a) take immediate corrective or remedial action as required by Paragraph 7.12, or otherwise; (b) promptly attempt to settle the claim as to all parties through negotiations with such owner or occupant, or otherwise resolve the claim by arbitration or other dispute resolution proceeding, or at law; and (c) to the fullest extent permitted by Laws and Regulations, indemnify and hold harmless Owner and Engineer, and the officers, directors, members, partners, employees, agents, consultants and subcontractors of each and any of them from and against any such claim, and against all costs, losses, and damages (including but not limited to all fees and charges of engineers, architects, attorneys, and other professionals and all court or arbitration or other dispute resolution costs) arising out of or relating to any claim or action, legal or equitable, brought by any such owner or occupant against Owner, Engineer, or any other party indemnified hereunder to the extent caused directly or indirectly, in whole or in part by, or based upon, Contractor's performance of the Work, or because of other actions or conduct of the Contractor or those for which Contractor is responsible.
- B. *Removal of Debris During Performance of the Work:* During the progress of the Work the Contractor shall keep the Site and other adjacent areas free from accumulations of waste materials, rubbish, and other debris. Removal and disposal of such waste materials, rubbish, and other debris shall conform to applicable Laws and Regulations.
- C. *Cleaning:* Prior to Substantial Completion of the Work Contractor shall clean the Site and the Work and make it ready for utilization by Owner. At the completion of the Work Contractor shall remove from the Site and adjacent areas all tools, appliances, construction equipment and machinery, and surplus materials and shall

restore to original condition all property not designated for alteration by the Contract Documents.

- D. *Loading of Structures*: Contractor shall not load nor permit any part of any structure to be loaded in any manner that will endanger the structure, nor shall Contractor subject any part of the Work or adjacent structures or land to stresses or pressures that will endanger them.

5.03 *Subsurface and Physical Conditions*

- A. *Reports and Drawings*: The Supplementary Conditions identify:

1. those reports known to Owner of explorations and tests of subsurface conditions at or adjacent to the Site;
2. those drawings known to Owner of physical conditions relating to existing surface or subsurface structures at the Site (except Underground Facilities); and
3. Technical Data contained in such reports and drawings.

- B. *Reliance by Contractor on Technical Data Authorized*: Contractor may rely upon the accuracy of the Technical Data expressly identified in the Supplementary Conditions with respect to such reports and drawings, but such reports and drawings are not Contract Documents. If no such express identification has been made, then Contractor may rely upon the accuracy of the Technical Data (as defined in Article 1) contained in any geotechnical or environmental report prepared for the Project and made available to Contractor. Except for such reliance on Technical Data, Contractor may not rely upon or make any claim against Owner or Engineer, or any of their officers, directors, members, partners, employees, agents, consultants, or subcontractors, with respect to:

1. the completeness of such reports and drawings for Contractor's purposes, including, but not limited to, any aspects of the means, methods, techniques, sequences, and procedures of construction to be employed by Contractor, and safety precautions and programs incident thereto; or
2. other data, interpretations, opinions, and information contained in such reports or shown or indicated in such drawings; or
3. any Contractor interpretation of or conclusion drawn from any Technical Data or any such other data, interpretations, opinions, or information.

5.04 *Differing Subsurface or Physical Conditions*

- A. *Notice by Contractor*: If Contractor believes that any subsurface or physical condition that is uncovered or revealed at the Site either:

1. is of such a nature as to establish that any Technical Data on which Contractor is entitled to rely as provided in Paragraph 5.03 is materially inaccurate; or
2. is of such a nature as to require a change in the Drawings or Specifications; or
3. differs materially from that shown or indicated in the Contract Documents; or

4. is of an unusual nature, and differs materially from conditions ordinarily encountered and generally recognized as inherent in work of the character provided for in the Contract Documents;

then Contractor shall, promptly after becoming aware thereof and before further disturbing the subsurface or physical conditions or performing any Work in connection therewith (except in an emergency as required by Paragraph 7.15), notify Owner and Engineer in writing about such condition. Contractor shall not further disturb such condition or perform any Work in connection therewith (except with respect to an emergency) until receipt of a written statement permitting Contractor to do so.

- B. *Engineer's Review:* After receipt of written notice as required by the preceding paragraph, Engineer will promptly review the subsurface or physical condition in question; determine the necessity of Owner's obtaining additional exploration or tests with respect to the condition; conclude whether the condition falls within any one or more of the differing site condition categories in Paragraph 5.04.A above; obtain any pertinent cost or schedule information from Contractor; prepare recommendations to Owner regarding the Contractor's resumption of Work in connection with the subsurface or physical condition in question and the need for any change in the Drawings or Specifications; and advise Owner in writing of Engineer's findings, conclusions, and recommendations.
- C. *Owner's Statement to Contractor Regarding Site Condition:* After receipt of Engineer's written findings, conclusions, and recommendations, Owner shall issue a written statement to Contractor (with a copy to Engineer) regarding the subsurface or physical condition in question, addressing the resumption of Work in connection with such condition, indicating whether any change in the Drawings or Specifications will be made, and adopting or rejecting Engineer's written findings, conclusions, and recommendations, in whole or in part.
- D. *Possible Price and Times Adjustments:*
  1. Contractor shall be entitled to an equitable adjustment in Contract Price or Contract Times, or both, to the extent that the existence of a differing subsurface or physical condition, or any related delay, disruption, or interference, causes an increase or decrease in Contractor's cost of, or time required for, performance of the Work; subject, however, to the following:
    - a. such condition must fall within any one or more of the categories described in Paragraph 5.04.A;
    - b. with respect to Work that is paid for on a unit price basis, any adjustment in Contract Price will be subject to the provisions of Paragraph 13.03; and,
    - c. Contractor's entitlement to an adjustment of the Contract Times is conditioned on such adjustment being essential to Contractor's ability to complete the Work within the Contract Times.



2. Contractor shall not be entitled to any adjustment in the Contract Price or Contract Times with respect to a subsurface or physical condition if:
  - a. Contractor knew of the existence of such condition at the time Contractor made a commitment to Owner with respect to Contract Price and Contract Times by the submission of a Bid or becoming bound under a negotiated contract, or otherwise; or
  - b. the existence of such condition reasonably could have been discovered or revealed as a result of any examination, investigation, exploration, test, or study of the Site and contiguous areas expressly required by the Bidding Requirements or Contract Documents to be conducted by or for Contractor prior to Contractor's making such commitment; or
  - c. Contractor failed to give the written notice as required by Paragraph 5.04.A.
3. If Owner and Contractor agree regarding Contractor's entitlement to and the amount or extent of any adjustment in the Contract Price or Contract Times, or both, then any such adjustment shall be set forth in a Change Order.
4. Contractor may submit a Change Proposal regarding its entitlement to or the amount or extent of any adjustment in the Contract Price or Contract Times, or both, no later than 30 days after Owner's issuance of the Owner's written statement to Contractor regarding the subsurface or physical condition in question.

5.05 *Underground Facilities*

- A. *Contractor's Responsibilities:* The information and data shown or indicated in the Contract Documents with respect to existing Underground Facilities at or adjacent to the Site is based on information and data furnished to Owner or Engineer by the owners of such Underground Facilities, including Owner, or by others. Unless it is otherwise expressly provided in the Supplementary Conditions:
  1. Owner and Engineer do not warrant or guarantee the accuracy or completeness of any such information or data provided by others; and
  2. the cost of all of the following will be included in the Contract Price, and Contractor shall have full responsibility for:
    - a. reviewing and checking all information and data regarding existing Underground Facilities at the Site;
    - b. locating all Underground Facilities shown or indicated in the Contract Documents as being at the Site;
    - c. coordination of the Work with the owners (including Owner) of such Underground Facilities, during construction; and
    - d. the safety and protection of all existing Underground Facilities at the Site, and repairing any damage thereto resulting from the Work.
- B. *Notice by Contractor:* If Contractor believes that an Underground Facility that is uncovered or revealed at the Site was not shown or indicated in the Contract

Documents, or was not shown or indicated with reasonable accuracy, then Contractor shall, promptly after becoming aware thereof and before further disturbing conditions affected thereby or performing any Work in connection therewith (except in an emergency as required by Paragraph 7.15), identify the owner of such Underground Facility and give written notice to that owner and to Owner and Engineer.

- C. *Engineer's Review:* Engineer will promptly review the Underground Facility and conclude whether such Underground Facility was not shown or indicated in the Contract Documents, or was not shown or indicated with reasonable accuracy; obtain any pertinent cost or schedule information from Contractor; prepare recommendations to Owner regarding the Contractor's resumption of Work in connection with the Underground Facility in question; determine the extent, if any, to which a change is required in the Drawings or Specifications to reflect and document the consequences of the existence or location of the Underground Facility; and advise Owner in writing of Engineer's findings, conclusions, and recommendations. During such time, Contractor shall be responsible for the safety and protection of such Underground Facility.
- D. *Owner's Statement to Contractor Regarding Underground Facility:* After receipt of Engineer's written findings, conclusions, and recommendations, Owner shall issue a written statement to Contractor (with a copy to Engineer) regarding the Underground Facility in question, addressing the resumption of Work in connection with such Underground Facility, indicating whether any change in the Drawings or Specifications will be made, and adopting or rejecting Engineer's written findings, conclusions, and recommendations in whole or in part.
- E. *Possible Price and Times Adjustments:*
  - 1. Contractor shall be entitled to an equitable adjustment in the Contract Price or Contract Times, or both, to the extent that any existing Underground Facility at the Site that was not shown or indicated in the Contract Documents, or was not shown or indicated with reasonable accuracy, or any related delay, disruption, or interference, causes an increase or decrease in Contractor's cost of, or time required for, performance of the Work; subject, however, to the following:
    - a. Contractor did not know of and could not reasonably have been expected to be aware of or to have anticipated the existence or actual location of the Underground Facility in question;
    - b. With respect to Work that is paid for on a unit price basis, any adjustment in Contract Price will be subject to the provisions of Paragraph 13.03;
    - c. Contractor's entitlement to an adjustment of the Contract Times is conditioned on such adjustment being essential to Contractor's ability to complete the Work within the Contract Times; and
    - d. Contractor gave the notice required in Paragraph 5.05.B.
  - 2. If Owner and Contractor agree regarding Contractor's entitlement to and the amount or extent of any adjustment in the Contract Price or Contract Times, or both, then any such adjustment shall be set forth in a Change Order.

3. Contractor may submit a Change Proposal regarding its entitlement to or the amount or extent of any adjustment in the Contract Price or Contract Times, or both, no later than 30 days after Owner's issuance of the Owner's written statement to Contractor regarding the Underground Facility in question.

5.06 *Hazardous Environmental Conditions at Site*

- A. *Reports and Drawings:* The Supplementary Conditions identify:
  1. those reports and drawings known to Owner relating to Hazardous Environmental Conditions that have been identified at or adjacent to the Site; and
  2. Technical Data contained in such reports and drawings.
- B. *Reliance by Contractor on Technical Data Authorized:* Contractor may rely upon the accuracy of the Technical Data expressly identified in the Supplementary Conditions with respect to such reports and drawings, but such reports and drawings are not Contract Documents. If no such express identification has been made, then Contractor may rely on the accuracy of the Technical Data (as defined in Article 1) contained in any geotechnical or environmental report prepared for the Project and made available to Contractor. Except for such reliance on Technical Data, Contractor may not rely upon or make any claim against Owner or Engineer, or any of their officers, directors, members, partners, employees, agents, consultants, or subcontractors with respect to:
  1. the completeness of such reports and drawings for Contractor's purposes, including, but not limited to, any aspects of the means, methods, techniques, sequences and procedures of construction to be employed by Contractor and safety precautions and programs incident thereto; or
  2. other data, interpretations, opinions and information contained in such reports or shown or indicated in such drawings; or
  3. any Contractor interpretation of or conclusion drawn from any Technical Data or any such other data, interpretations, opinions or information.
- C. Contractor shall not be responsible for removing or remediating any Hazardous Environmental Condition encountered, uncovered, or revealed at the Site unless such removal or remediation is expressly identified in the Contract Documents to be within the scope of the Work.
- D. Contractor shall be responsible for controlling, containing, and duly removing all Constituents of Concern brought to the Site by Contractor, Subcontractors, Suppliers, or anyone else for whom Contractor is responsible, and for any associated costs; and for the costs of removing and remediating any Hazardous Environmental Condition created by the presence of any such Constituents of Concern.
- E. If Contractor encounters, uncovers, or reveals a Hazardous Environmental Condition whose removal or remediation is not expressly identified in the Contract Documents as being within the scope of the Work, or if Contractor or anyone for whom Contractor is responsible creates a Hazardous Environmental Condition, then Contractor shall immediately: (1) secure or otherwise isolate such condition; (2) stop

all Work in connection with such condition and in any area affected thereby (except in an emergency as required by Paragraph 7.15); and (3) notify Owner and Engineer (and promptly thereafter confirm such notice in writing). Owner shall promptly consult with Engineer concerning the necessity for Owner to retain a qualified expert to evaluate such condition or take corrective action, if any. Promptly after consulting with Engineer, Owner shall take such actions as are necessary to permit Owner to timely obtain required permits and provide Contractor the written notice required by Paragraph 5.06.F. If Contractor or anyone for whom Contractor is responsible created the Hazardous Environmental Condition in question, then Owner may remove and remediate the Hazardous Environmental Condition, and impose a set-off against payments to account for the associated costs.

- F. Contractor shall not resume Work in connection with such Hazardous Environmental Condition or in any affected area until after Owner has obtained any required permits related thereto, and delivered written notice to Contractor either (1) specifying that such condition and any affected area is or has been rendered safe for the resumption of Work, or (2) specifying any special conditions under which such Work may be resumed safely.
- G. If Owner and Contractor cannot agree as to entitlement to or on the amount or extent, if any, of any adjustment in Contract Price or Contract Times, or both, as a result of such Work stoppage or such special conditions under which Work is agreed to be resumed by Contractor, then within 30 days of Owner's written notice regarding the resumption of Work, Contractor may submit a Change Proposal, or Owner may impose a set-off.
- H. If after receipt of such written notice Contractor does not agree to resume such Work based on a reasonable belief it is unsafe, or does not agree to resume such Work under such special conditions, then Owner may order the portion of the Work that is in the area affected by such condition to be deleted from the Work, following the contractual change procedures in Article 11. Owner may have such deleted portion of the Work performed by Owner's own forces or others in accordance with Article 8.
- I. To the fullest extent permitted by Laws and Regulations, Owner shall indemnify and hold harmless Contractor, Subcontractors, and Engineer, and the officers, directors, members, partners, employees, agents, consultants, and subcontractors of each and any of them from and against all claims, costs, losses, and damages (including but not limited to all fees and charges of engineers, architects, attorneys, and other professionals and all court or arbitration or other dispute resolution costs) arising out of or relating to a Hazardous Environmental Condition, provided that such Hazardous Environmental Condition (1) was not shown or indicated in the Drawings, Specifications, or other Contract Documents, identified as Technical Data entitled to limited reliance pursuant to Paragraph 5.06.B, or identified in the Contract Documents to be included within the scope of the Work, and (2) was not created by Contractor or by anyone for whom Contractor is responsible. Nothing in this Paragraph 5.06.I shall obligate Owner to indemnify any individual or entity from and against the consequences of that individual's or entity's own negligence.

- J. To the fullest extent permitted by Laws and Regulations, Contractor shall indemnify and hold harmless Owner and Engineer, and the officers, directors, members, partners, employees, agents, consultants, and subcontractors of each and any of them from and against all claims, costs, losses, and damages (including but not limited to all fees and charges of engineers, architects, attorneys, and other professionals and all court or arbitration or other dispute resolution costs) arising out of or relating to the failure to control, contain, or remove a Constituent of Concern brought to the Site by Contractor or by anyone for whom Contractor is responsible, or to a Hazardous Environmental Condition created by Contractor or by anyone for whom Contractor is responsible. Nothing in this Paragraph 5.06.J shall obligate Contractor to indemnify any individual or entity from and against the consequences of that individual's or entity's own negligence.
- K. The provisions of Paragraphs 5.03, 5.04, and 5.05 do not apply to the presence of Constituents of Concern or to a Hazardous Environmental Condition uncovered or revealed at the Site.

## **ARTICLE 6 – BONDS AND INSURANCE**

### *6.01 Performance, Payment, and Other Bonds*

- A. Contractor shall furnish a performance bond and a payment bond, each in an amount at least equal to the Contract Price, as security for the faithful performance and payment of all of Contractor's obligations under the Contract. These bonds shall remain in effect until one year after the date when final payment becomes due or until completion of the correction period specified in Paragraph 15.08, whichever is later, except as provided otherwise by Laws or Regulations, the Supplementary Conditions, or other specific provisions of the Contract. Contractor shall also furnish such other bonds as are required by the Supplementary Conditions or other specific provisions of the Contract.
- B. All bonds shall be in the form prescribed by the Contract except as provided otherwise by Laws or Regulations, and shall be executed by such sureties as are named in "Companies Holding Certificates of Authority as Acceptable Sureties on Federal Bonds and as Acceptable Reinsuring Companies" as published in Circular 570 (as amended and supplemented) by the Financial Management Service, Surety Bond Branch, U.S. Department of the Treasury. A bond signed by an agent or attorney-in-fact must be accompanied by a certified copy of that individual's authority to bind the surety. The evidence of authority shall show that it is effective on the date the agent or attorney-in-fact signed the accompanying bond.
- C. Contractor shall obtain the required bonds from surety companies that are duly licensed or authorized in the jurisdiction in which the Project is located to issue bonds in the required amounts.
- D. If the surety on a bond furnished by Contractor is declared bankrupt or becomes insolvent, or its right to do business is terminated in any state or jurisdiction where any part of the Project is located, or the surety ceases to meet the requirements above, then Contractor shall promptly notify Owner and Engineer and shall, within

20 days after the event giving rise to such notification, provide another bond and surety, both of which shall comply with the bond and surety requirements above.

- E. If Contractor has failed to obtain a required bond, Owner may exclude the Contractor from the Site and exercise Owner's termination rights under Article 16.
- F. Upon request, Owner shall provide a copy of the payment bond to any Subcontractor, Supplier, or other person or entity claiming to have furnished labor or materials used in the performance of the Work.

#### 6.02 *Insurance—General Provisions*

- A. Owner and Contractor shall obtain and maintain insurance as required in this Article and in the Supplementary Conditions.
- B. All insurance required by the Contract to be purchased and maintained by Owner or Contractor shall be obtained from insurance companies that are duly licensed or authorized, in the state or jurisdiction in which the Project is located, to issue insurance policies for the required limits and coverages. Unless a different standard is indicated in the Supplementary Conditions, all companies that provide insurance policies required under this Contract shall have an A.M. Best rating of A-VII or better.
- C. Contractor shall deliver to Owner, with copies to each named insured and additional insured (as identified in this Article, in the Supplementary Conditions, or elsewhere in the Contract), certificates of insurance establishing that Contractor has obtained and is maintaining the policies, coverages, and endorsements required by the Contract. Upon request by Owner or any other insured, Contractor shall also furnish other evidence of such required insurance, including but not limited to copies of policies and endorsements, and documentation of applicable self-insured retentions and deductibles. Contractor may block out (redact) any confidential premium or pricing information contained in any policy or endorsement furnished under this provision.
- D. Owner shall deliver to Contractor, with copies to each named insured and additional insured (as identified in this Article, the Supplementary Conditions, or elsewhere in the Contract), certificates of insurance establishing that Owner has obtained and is maintaining the policies, coverages, and endorsements required of Owner by the Contract (if any). Upon request by Contractor or any other insured, Owner shall also provide other evidence of such required insurance (if any), including but not limited to copies of policies and endorsements, and documentation of applicable self-insured retentions and deductibles. Owner may block out (redact) any confidential premium or pricing information contained in any policy or endorsement furnished under this provision.
- E. Failure of Owner or Contractor to demand such certificates or other evidence of the other party's full compliance with these insurance requirements, or failure of Owner or Contractor to identify a deficiency in compliance from the evidence provided, shall not be construed as a waiver of the other party's obligation to obtain and maintain such insurance.

- F. If either party does not purchase or maintain all of the insurance required of such party by the Contract, such party shall notify the other party in writing of such failure to purchase prior to the start of the Work, or of such failure to maintain prior to any change in the required coverage.
- G. If Contractor has failed to obtain and maintain required insurance, Owner may exclude the Contractor from the Site, impose an appropriate set-off against payment, and exercise Owner's termination rights under Article 16.
- H. Without prejudice to any other right or remedy, if a party has failed to obtain required insurance, the other party may elect to obtain equivalent insurance to protect such other party's interests at the expense of the party who was required to provide such coverage, and the Contract Price shall be adjusted accordingly.
- I. Owner does not represent that insurance coverage and limits established in this Contract necessarily will be adequate to protect Contractor or Contractor's interests.
- J. The insurance and insurance limits required herein shall not be deemed as a limitation on Contractor's liability under the indemnities granted to Owner and other individuals and entities in the Contract.

6.03 *Contractor's Insurance*

- A. *Workers' Compensation*: Contractor shall purchase and maintain workers' compensation and employer's liability insurance for:
  - 1. claims under workers' compensation, disability benefits, and other similar employee benefit acts.
  - 2. United States Longshoreman and Harbor Workers' Compensation Act and Jones Act coverage (if applicable).
  - 3. claims for damages because of bodily injury, occupational sickness or disease, or death of Contractor's employees (by stop-gap endorsement in monopolist worker's compensation states).
  - 4. Foreign voluntary worker compensation (if applicable).
- B. *Commercial General Liability—Claims Covered*: Contractor shall purchase and maintain commercial general liability insurance, covering all operations by or on behalf of Contractor, on an occurrence basis, against:
  - 1. claims for damages because of bodily injury, sickness or disease, or death of any person other than Contractor's employees.
  - 2. claims for damages insured by reasonably available personal injury liability coverage.
  - 3. claims for damages, other than to the Work itself, because of injury to or destruction of tangible property wherever located, including loss of use resulting therefrom.
- C. *Commercial General Liability—Form and Content*: Contractor's commercial liability policy shall be written on a 1996 (or later) ISO commercial general liability form (occurrence form) and include the following coverages and endorsements:

1. Products and completed operations coverage:
    - a. Such insurance shall be maintained for three years after final payment.
    - b. Contractor shall furnish Owner and each other additional insured (as identified in the Supplementary Conditions or elsewhere in the Contract) evidence of continuation of such insurance at final payment and three years thereafter.
  2. Blanket contractual liability coverage, to the extent permitted by law, including but not limited to coverage of Contractor's contractual indemnity obligations in Paragraph 7.18.
  3. Broad form property damage coverage.
  4. Severability of interest.
  5. Underground, explosion, and collapse coverage.
  6. Personal injury coverage.
  7. Additional insured endorsements that include both ongoing operations and products and completed operations coverage through ISO Endorsements CG 20 10 10 01 and CG 20 37 10 01 (together); or CG 20 10 07 04 and CG 20 37 07 04 (together); or their equivalent.
  8. For design professional additional insureds, ISO Endorsement CG 20 32 07 04, "Additional Insured—Engineers, Architects or Surveyors Not Engaged by the Named Insured" or its equivalent.
- D. *Automobile liability*: Contractor shall purchase and maintain automobile liability insurance against claims for damages because of bodily injury or death of any person or property damage arising out of the ownership, maintenance, or use of any motor vehicle. The automobile liability policy shall be written on an occurrence basis.
- E. *Umbrella or excess liability*: Contractor shall purchase and maintain umbrella or excess liability insurance written over the underlying employer's liability, commercial general liability, and automobile liability insurance described in the paragraphs above. Subject to industry-standard exclusions, the coverage afforded shall follow form as to each and every one of the underlying policies.
- F. *Contractor's pollution liability insurance*: Contractor shall purchase and maintain a policy covering third-party injury and property damage claims, including clean-up costs, as a result of pollution conditions arising from Contractor's operations and completed operations. This insurance shall be maintained for no less than three years after final completion.
- G. *Additional insureds*: The Contractor's commercial general liability, automobile liability, umbrella or excess, and pollution liability policies shall include and list as additional insureds Owner and Engineer, and any individuals or entities identified in the Supplementary Conditions; include coverage for the respective officers, directors, members, partners, employees, agents, consultants, and subcontractors of each and any of all such additional insureds; and the insurance afforded to these additional insureds shall provide primary coverage for all claims covered thereby



(including as applicable those arising from both ongoing and completed operations) on a non-contributory basis. Contractor shall obtain all necessary endorsements to support these requirements. All insurance provided by the Contractor shall be primary and non-contributory with respect to any other insurance available to Additional Insureds.

- H. *Waivers of Subrogation:* The Contractor's commercial general liability, automobile liability, workers' compensation, umbrella or excess liability and pollution liability policies shall provide a Waiver of Subrogation in favor of the Owner and respective officers, directors, members, partners, employees and agents.
- I. *Contractor's professional liability insurance:* If Contractor will provide or furnish professional services under this Contract, through a delegation of professional design services or otherwise, then Contractor shall be responsible for purchasing and maintaining applicable professional liability insurance. This insurance shall provide protection against claims arising out of performance of professional design or related services, and caused by a negligent error, omission, or act for which the insured party is legally liable. It shall be maintained throughout the duration of the Contract and for a minimum of two years after Substantial Completion. If such professional design services are performed by a Subcontractor, and not by Contractor itself, then the requirements of this paragraph may be satisfied through the purchasing and maintenance of such insurance by such Subcontractor.
- J. *General provisions:* The policies of insurance required by this Paragraph 6.03 shall:
  - 1. include at least the specific coverages provided in this Article.
  - 2. be written for not less than the limits of liability provided in this Article and in the Supplementary Conditions, or required by Laws or Regulations, whichever is greater.
  - 3. contain a provision or endorsement that the coverage afforded will not be canceled, materially changed, or renewal refused until at least 10 days prior written notice has been given to Contractor. Within three days of receipt of any such written notice, Contractor shall provide a copy of the notice to Owner, Engineer, and each other insured under the policy.
  - 4. remain in effect at least until final payment (and longer if expressly required in this Article) and at all times thereafter when Contractor may be correcting, removing, or replacing defective Work as a warranty or correction obligation, or otherwise, or returning to the Site to conduct other tasks arising from the Contract Documents.
  - 5. be appropriate for the Work being performed and provide protection from claims that may arise out of or result from Contractor's performance of the Work and Contractor's other obligations under the Contract Documents, whether it is to be performed by Contractor, any Subcontractor or Supplier, or by anyone directly or indirectly employed by any of them to perform any of the Work, or by anyone for whose acts any of them may be liable.

- K. The coverage requirements for specific policies of insurance must be met by such policies, and not by reference to excess or umbrella insurance provided in other policies.

6.04 *Owner's Liability Insurance*

- A. In addition to the insurance required to be provided by Contractor under Paragraph 6.03, Owner, at Owner's option, may purchase and maintain at Owner's expense Owner's own liability insurance as will protect Owner against claims which may arise from operations under the Contract Documents.
- B. Owner's liability policies, if any, operate separately and independently from policies required to be provided by Contractor, and Contractor cannot rely upon Owner's liability policies for any of Contractor's obligations to the Owner, Engineer, or third parties.

6.05 *Property Insurance*

- A. *Builder's Risk:* Unless otherwise provided in the Supplementary Conditions, Contractor shall purchase and maintain builder's risk insurance upon the Work on a completed value basis, in the amount of the full insurable replacement cost thereof (subject to such deductible amounts as may be provided in the Supplementary Conditions or required by Laws and Regulations). This insurance shall:
  - 1. include the Owner and Contractor as named insureds, and all Subcontractors, and any individuals or entities required by the Supplementary Conditions to be insured under such builder's risk policy, as insureds or named insureds. For purposes of the remainder of this Paragraph 6.05, Paragraphs 6.06 and 6.07, and any corresponding Supplementary Conditions, the parties required to be insured shall collectively be referred to as "insureds."
  - 2. be written on a builder's risk "all risk" policy form that shall at least include insurance for physical loss or damage to the Work, temporary buildings, falsework, and materials and equipment in transit, and shall insure against at least the following perils or causes of loss: fire; lightning; windstorm; riot; civil commotion; terrorism; vehicle impact; aircraft; smoke; theft; vandalism and malicious mischief; mechanical breakdown, boiler explosion, and artificially generated electric current; earthquake; volcanic activity, and other earth movement; flood; collapse; explosion; debris removal; demolition occasioned by enforcement of Laws and Regulations; water damage (other than that caused by flood); and such other perils or causes of loss as may be specifically required by the Supplementary Conditions. If insurance against mechanical breakdown, boiler explosion, and artificially generated electric current; earthquake; volcanic activity, and other earth movement; or flood, are not commercially available under builder's risk policies, by endorsement or otherwise, such insurance may be provided through other insurance policies acceptable to Owner and Contractor.
  - 3. cover, as insured property, at least the following: (a) the Work and all materials, supplies, machinery, apparatus, equipment, fixtures, and other property of a similar nature that are to be incorporated into or used in the preparation,

fabrication, construction, erection, or completion of the Work, including Owner-furnished or assigned property; (b) spare parts inventory required within the scope of the Contract; and (c) temporary works which are not intended to form part of the permanent constructed Work but which are intended to provide working access to the Site, or to the Work under construction, or which are intended to provide temporary support for the Work under construction, including scaffolding, form work, fences, shoring, falsework, and temporary structures.

4. cover expenses incurred in the repair or replacement of any insured property (including but not limited to fees and charges of engineers and architects).
  5. extend to cover damage or loss to insured property while in temporary storage at the Site or in a storage location outside the Site (but not including property stored at the premises of a manufacturer or Supplier).
  6. extend to cover damage or loss to insured property while in transit.
  7. allow for partial occupation or use of the Work by Owner, such that those portions of the Work that are not yet occupied or used by Owner shall remain covered by the builder's risk insurance.
  8. allow for the waiver of the insurer's subrogation rights, as set forth below.
  9. provide primary coverage for all losses and damages caused by the perils or causes of loss covered.
  10. not include a co-insurance clause.
  11. include an exception for ensuing losses from physical damage or loss with respect to any defective workmanship, design, or materials exclusions.
  12. include performance/hot testing and start-up.
  13. be maintained in effect, subject to the provisions herein regarding Substantial Completion and partial occupancy or use of the Work by Owner, until the Work is complete.
- B. *Notice of Cancellation or Change:* All the policies of insurance (and the certificates or other evidence thereof) required to be purchased and maintained in accordance with this Paragraph 6.05 will contain a provision or endorsement that the coverage afforded will not be canceled or materially changed or renewal refused until at least 10 days prior written notice has been given to the purchasing policyholder. Within three days of receipt of any such written notice, the purchasing policyholder shall provide a copy of the notice to each other insured.
- C. *Deductibles:* The purchaser of any required builder's risk or property insurance shall pay for costs not covered because of the application of a policy deductible.
- D. *Partial Occupancy or Use by Owner:* If Owner will occupy or use a portion or portions of the Work prior to Substantial Completion of all the Work as provided in Paragraph 15.04, then Owner (directly, if it is the purchaser of the builder's risk policy, or through Contractor) will provide notice of such occupancy or use to the builder's risk insurer. The builder's risk insurance shall not be canceled or permitted

to lapse on account of any such partial use or occupancy; rather, those portions of the Work that are occupied or used by Owner may come off the builder's risk policy, while those portions of the Work not yet occupied or used by Owner shall remain covered by the builder's risk insurance.

- E. *Additional Insurance*: If Contractor elects to obtain other special insurance to be included in or supplement the builder's risk or property insurance policies provided under this Paragraph 6.05, it may do so at Contractor's expense.
- F. *Insurance of Other Property*: If the express insurance provisions of the Contract do not require or address the insurance of a property item or interest, such as tools, construction equipment, or other personal property owned by Contractor, a Subcontractor, or an employee of Contractor or a Subcontractor, then the entity or individual owning such property item will be responsible for deciding whether to insure it, and if so in what amount.

#### 6.06 *Waiver of Rights*

- A. All policies purchased in accordance with Paragraph 6.05, expressly including the builder's risk policy, shall contain provisions to the effect that in the event of payment of any loss or damage the insurers will have no rights of recovery against any insureds thereunder, or against Engineer or its consultants, or their officers, directors, members, partners, employees, agents, consultants, or subcontractors. Owner and Contractor waive all rights against each other and the respective officers, directors, members, partners, employees, agents, consultants, and subcontractors of each and any of them, for all losses and damages caused by, arising out of, or resulting from any of the perils or causes of loss covered by such policies and any other property insurance applicable to the Work; and, in addition, waive all such rights against Engineer, its consultants, all Subcontractors, all individuals or entities identified in the Supplementary Conditions as insureds, and the officers, directors, members, partners, employees, agents, consultants, and subcontractors of each and any of them, under such policies for losses and damages so caused. None of the above waivers shall extend to the rights that any party making such waiver may have to the proceeds of insurance held by Owner or Contractor as trustee or fiduciary, or otherwise payable under any policy so issued.
- B. Owner waives all rights against Contractor, Subcontractors, and Engineer, and the officers, directors, members, partners, employees, agents, consultants and subcontractors of each and any of them, for:
  - 1. loss due to business interruption, loss of use, or other consequential loss extending beyond direct physical loss or damage to Owner's property or the Work caused by, arising out of, or resulting from fire or other perils whether or not insured by Owner; and
  - 2. loss or damage to the completed Project or part thereof caused by, arising out of, or resulting from fire or other insured peril or cause of loss covered by any property insurance maintained on the completed Project or part thereof by Owner during partial occupancy or use pursuant to Paragraph 15.04, after

Substantial Completion pursuant to Paragraph 15.03, or after final payment pursuant to Paragraph 15.06.

- C. Any insurance policy maintained by Owner covering any loss, damage or consequential loss referred to in Paragraph 6.06.B shall contain provisions to the effect that in the event of payment of any such loss, damage, or consequential loss, the insurers will have no rights of recovery against Contractor, Subcontractors, or Engineer, or the officers, directors, members, partners, employees, agents, consultants, or subcontractors of each and any of them.
- D. Contractor shall be responsible for assuring that the agreement under which a Subcontractor performs a portion of the Work contains provisions whereby the Subcontractor waives all rights against Owner, Contractor, all individuals or entities identified in the Supplementary Conditions as insureds, the Engineer and its consultants, and the officers, directors, members, partners, employees, agents, consultants, and subcontractors of each and any of them, for all losses and damages caused by, arising out of, relating to, or resulting from any of the perils or causes of loss covered by builder's risk insurance and any other property insurance applicable to the Work.

6.07 *Receipt and Application of Property Insurance Proceeds*

- A. Any insured loss under the builder's risk and other policies of insurance required by Paragraph 6.05 will be adjusted and settled with the named insured that purchased the policy. Such named insured shall act as fiduciary for the other insureds, and give notice to such other insureds that adjustment and settlement of a claim is in progress. Any other insured may state its position regarding a claim for insured loss in writing within 15 days after notice of such claim.
- B. Proceeds for such insured losses may be made payable by the insurer either jointly to multiple insureds, or to the named insured that purchased the policy in its own right and as fiduciary for other insureds, subject to the requirements of any applicable mortgage clause. A named insured receiving insurance proceeds under the builder's risk and other policies of insurance required by Paragraph 6.05 shall distribute such proceeds in accordance with such agreement as the parties in interest may reach, or as otherwise required under the dispute resolution provisions of this Contract or applicable Laws and Regulations.
- C. If no other special agreement is reached, the damaged Work shall be repaired or replaced, the money so received applied on account thereof, and the Work and the cost thereof covered by Change Order, if needed.

**ARTICLE 7 – CONTRACTOR'S RESPONSIBILITIES**

7.01 *Supervision and Superintendence*

- A. Contractor shall supervise, inspect, and direct the Work competently and efficiently, devoting such attention thereto and applying such skills and expertise as may be necessary to perform the Work in accordance with the Contract Documents. Contractor shall be solely responsible for the means, methods, techniques, sequences, and procedures of construction.

- B. At all times during the progress of the Work, Contractor shall assign a competent resident superintendent who shall not be replaced without written notice to Owner and Engineer except under extraordinary circumstances.

7.02 *Labor; Working Hours*

- A. Contractor shall provide competent, suitably qualified personnel to survey and lay out the Work and perform construction as required by the Contract Documents. Contractor shall at all times maintain good discipline and order at the Site.
- B. Except as otherwise required for the safety or protection of persons or the Work or property at the Site or adjacent thereto, and except as otherwise stated in the Contract Documents, all Work at the Site shall be performed during regular working hours, Monday through Friday. Contractor will not perform Work on a Saturday, Sunday, or any legal holiday. Contractor may perform Work outside regular working hours or on Saturdays, Sundays, or legal holidays only with Owner's written consent, which will not be unreasonably withheld.

7.03 *Services, Materials, and Equipment*

- A. Unless otherwise specified in the Contract Documents, Contractor shall provide and assume full responsibility for all services, materials, equipment, labor, transportation, construction equipment and machinery, tools, appliances, fuel, power, light, heat, telephone, water, sanitary facilities, temporary facilities, and all other facilities and incidentals necessary for the performance, testing, start up, and completion of the Work, whether or not such items are specifically called for in the Contract Documents.
- B. All materials and equipment incorporated into the Work shall be of good quality and new, except as otherwise provided in the Contract Documents. All special warranties and guarantees required by the Specifications shall expressly run to the benefit of Owner. If required by Engineer, Contractor shall furnish satisfactory evidence (including reports of required tests) as to the source, kind, and quality of materials and equipment.
- C. All materials and equipment shall be stored, applied, installed, connected, erected, protected, used, cleaned, and conditioned in accordance with instructions of the applicable Supplier, except as otherwise may be provided in the Contract Documents.

7.04 *"Or Equals"*

- A. Whenever an item of material or equipment is specified or described in the Contract Documents by using the name of a proprietary item or the name of a particular Supplier, the Contract Price has been based upon Contractor furnishing such item as specified. The specification or description of such an item is intended to establish the type, function, appearance, and quality required. Unless the specification or description contains or is followed by words reading that no like, equivalent, or "or equal" item is permitted, Contractor may request that Engineer authorize the use of other items of material or equipment, or items from other proposed suppliers under the circumstances described below.

1. If Engineer in its sole discretion determines that an item of material or equipment proposed by Contractor is functionally equal to that named and sufficiently similar so that no change in related Work will be required, Engineer shall deem it an “or equal” item. For the purposes of this paragraph, a proposed item of material or equipment will be considered functionally equal to an item so named if:
  - a. in the exercise of reasonable judgment Engineer determines that:
    - 1) it is at least equal in materials of construction, quality, durability, appearance, strength, and design characteristics;
    - 2) it will reliably perform at least equally well the function and achieve the results imposed by the design concept of the completed Project as a functioning whole;
    - 3) it has a proven record of performance and availability of responsive service; and
    - 4) it is not objectionable to Owner.
  - b. Contractor certifies that, if approved and incorporated into the Work:
    - 1) there will be no increase in cost to the Owner or increase in Contract Times; and
    - 2) it will conform substantially to the detailed requirements of the item named in the Contract Documents.
- B. *Contractor’s Expense:* Contractor shall provide all data in support of any proposed “or equal” item at Contractor’s expense.
- C. *Engineer’s Evaluation and Determination:* Engineer will be allowed a reasonable time to evaluate each “or-equal” request. Engineer may require Contractor to furnish additional data about the proposed “or-equal” item. Engineer will be the sole judge of acceptability. No “or-equal” item will be ordered, furnished, installed, or utilized until Engineer’s review is complete and Engineer determines that the proposed item is an “or-equal”, which will be evidenced by an approved Shop Drawing or other written communication. Engineer will advise Contractor in writing of any negative determination.
- D. *Effect of Engineer’s Determination:* Neither approval nor denial of an “or-equal” request shall result in any change in Contract Price. The Engineer’s denial of an “or-equal” request shall be final and binding, and may not be reversed through an appeal under any provision of the Contract Documents.
- E. *Treatment as a Substitution Request:* If Engineer determines that an item of material or equipment proposed by Contractor does not qualify as an “or-equal” item, Contractor may request that Engineer considered the proposed item as a substitute pursuant to Paragraph 7.05.

## 7.05 *Substitutes*

- A. Unless the specification or description of an item of material or equipment required to be furnished under the Contract Documents contains or is followed by words reading that no substitution is permitted, Contractor may request that Engineer authorize the use of other items of material or equipment under the circumstances described below. To the extent possible such requests shall be made before commencement of related construction at the Site.
1. Contractor shall submit sufficient information as provided below to allow Engineer to determine if the item of material or equipment proposed is functionally equivalent to that named and an acceptable substitute therefor. Engineer will not accept requests for review of proposed substitute items of material or equipment from anyone other than Contractor.
  2. The requirements for review by Engineer will be as set forth in Paragraph 7.05.B, as supplemented by the Specifications, and as Engineer may decide is appropriate under the circumstances.
  3. Contractor shall make written application to Engineer for review of a proposed substitute item of material or equipment that Contractor seeks to furnish or use. The application:
    - a. shall certify that the proposed substitute item will:
      - 1) perform adequately the functions and achieve the results called for by the general design,
      - 2) be similar in substance to that specified, and
      - 3) be suited to the same use as that specified.
    - b. will state:
      - 1) the extent, if any, to which the use of the proposed substitute item will necessitate a change in Contract Times,
      - 2) whether use of the proposed substitute item in the Work will require a change in any of the Contract Documents (or in the provisions of any other direct contract with Owner for other work on the Project) to adapt the design to the proposed substitute item, and
      - 3) whether incorporation or use of the proposed substitute item in connection with the Work is subject to payment of any license fee or royalty.
    - c. will identify:
      - 1) all variations of the proposed substitute item from that specified, and
      - 2) available engineering, sales, maintenance, repair, and replacement services.
    - d. shall contain an itemized estimate of all costs or credits that will result directly or indirectly from use of such substitute item, including but not



limited to changes in Contract Price, shared savings, costs of redesign, and claims of other contractors affected by any resulting change.

- B. *Engineer's Evaluation and Determination:* Engineer will be allowed a reasonable time to evaluate each substitute request, and to obtain comments and direction from Owner. Engineer may require Contractor to furnish additional data about the proposed substitute item. Engineer will be the sole judge of acceptability. No substitute will be ordered, furnished, installed, or utilized until Engineer's review is complete and Engineer determines that the proposed item is an acceptable substitute. Engineer's determination will be evidenced by a Field Order or a proposed Change Order accounting for the substitution itself and all related impacts, including changes in Contract Price or Contract Times. Engineer will advise Contractor in writing of any negative determination.
- C. *Special Guarantee:* Owner may require Contractor to furnish at Contractor's expense a special performance guarantee or other surety with respect to any substitute.
- D. *Reimbursement of Engineer's Cost:* Engineer will record Engineer's costs in evaluating a substitute proposed or submitted by Contractor. Whether or not Engineer approves a substitute so proposed or submitted by Contractor, Contractor shall reimburse Owner for the reasonable charges of Engineer for evaluating each such proposed substitute. Contractor shall also reimburse Owner for the reasonable charges of Engineer for making changes in the Contract Documents (or in the provisions of any other direct contract with Owner) resulting from the acceptance of each proposed substitute.
- E. *Contractor's Expense:* Contractor shall provide all data in support of any proposed substitute at Contractor's expense.
- F. *Effect of Engineer's Determination:* If Engineer approves the substitution request, Contractor shall execute the proposed Change Order and proceed with the substitution. The Engineer's denial of a substitution request shall be final and binding, and may not be reversed through an appeal under any provision of the Contract Documents. Contractor may challenge the scope of reimbursement costs imposed under Paragraph 7.05.D, by timely submittal of a Change Proposal.

#### 7.06 *Concerning Subcontractors, Suppliers, and Others*

- A. Contractor may retain Subcontractors and Suppliers for the performance of parts of the Work. Such Subcontractors and Suppliers must be acceptable to Owner.
- B. Contractor shall retain specific Subcontractors, Suppliers, or other individuals or entities for the performance of designated parts of the Work if required by the Contract to do so.
- C. Subsequent to the submittal of Contractor's Bid or final negotiation of the terms of the Contract, Owner may not require Contractor to retain any Subcontractor, Supplier, or other individual or entity to furnish or perform any of the Work against which Contractor has reasonable objection.
- D. Prior to entry into any binding subcontract or purchase order, Contractor shall submit to Owner the identity of the proposed Subcontractor or Supplier (unless Owner has

already deemed such proposed Subcontractor or Supplier acceptable, during the bidding process or otherwise). Such proposed Subcontractor or Supplier shall be deemed acceptable to Owner unless Owner raises a substantive, reasonable objection within five days.

- E. Owner may require the replacement of any Subcontractor, Supplier, or other individual or entity retained by Contractor to perform any part of the Work. Owner also may require Contractor to retain specific replacements; provided, however, that Owner may not require a replacement to which Contractor has a reasonable objection. If Contractor has submitted the identity of certain Subcontractors, Suppliers, or other individuals or entities for acceptance by Owner, and Owner has accepted it (either in writing or by failing to make written objection thereto), then Owner may subsequently revoke the acceptance of any such Subcontractor, Supplier, or other individual or entity so identified solely on the basis of substantive, reasonable objection after due investigation. Contractor shall submit an acceptable replacement for the rejected Subcontractor, Supplier, or other individual or entity.
- F. If Owner requires the replacement of any Subcontractor, Supplier, or other individual or entity retained by Contractor to perform any part of the Work, then Contractor shall be entitled to an adjustment in Contract Price or Contract Times, or both, with respect to the replacement; and Contractor shall initiate a Change Proposal for such adjustment within 30 days of Owner's requirement of replacement.
- G. No acceptance by Owner of any such Subcontractor, Supplier, or other individual or entity, whether initially or as a replacement, shall constitute a waiver of the right of Owner to the completion of the Work in accordance with the Contract Documents.
- H. On a monthly basis Contractor shall submit to Engineer a complete list of all Subcontractors and Suppliers having a direct contract with Contractor, and of all other Subcontractors and Suppliers known to Contractor at the time of submittal.
- I. Contractor shall be fully responsible to Owner and Engineer for all acts and omissions of the Subcontractors, Suppliers, and other individuals or entities performing or furnishing any of the Work just as Contractor is responsible for Contractor's own acts and omissions.
- J. Contractor shall be solely responsible for scheduling and coordinating the work of Subcontractors, Suppliers, and all other individuals or entities performing or furnishing any of the Work.
- K. Contractor shall restrict all Subcontractors, Suppliers, and such other individuals or entities performing or furnishing any of the Work from communicating with Engineer or Owner, except through Contractor or in case of an emergency, or as otherwise expressly allowed herein.
- L. The divisions and sections of the Specifications and the identifications of any Drawings shall not control Contractor in dividing the Work among Subcontractors or Suppliers or delineating the Work to be performed by any specific trade.
- M. All Work performed for Contractor by a Subcontractor or Supplier shall be pursuant to an appropriate contractual agreement that specifically binds the Subcontractor or

Supplier to the applicable terms and conditions of the Contract Documents for the benefit of Owner and Engineer.

- N. Owner may furnish to any Subcontractor or Supplier, to the extent practicable, information about amounts paid to Contractor on account of Work performed for Contractor by the particular Subcontractor or Supplier.
- O. Nothing in the Contract Documents:
  - 1. shall create for the benefit of any such Subcontractor, Supplier, or other individual or entity any contractual relationship between Owner or Engineer and any such Subcontractor, Supplier, or other individual or entity; nor
  - 2. shall create any obligation on the part of Owner or Engineer to pay or to see to the payment of any money due any such Subcontractor, Supplier, or other individual or entity except as may otherwise be required by Laws and Regulations.

#### 7.07 *Patent Fees and Royalties*

- A. Contractor shall pay all license fees and royalties and assume all costs incident to the use in the performance of the Work or the incorporation in the Work of any invention, design, process, product, or device which is the subject of patent rights or copyrights held by others. If a particular invention, design, process, product, or device is specified in the Contract Documents for use in the performance of the Work and if, to the actual knowledge of Owner or Engineer, its use is subject to patent rights or copyrights calling for the payment of any license fee or royalty to others, the existence of such rights shall be disclosed by Owner in the Contract Documents.
- B. To the fullest extent permitted by Laws and Regulations, Owner shall indemnify and hold harmless Contractor, and its officers, directors, members, partners, employees, agents, consultants, and subcontractors from and against all claims, costs, losses, and damages (including but not limited to all fees and charges of engineers, architects, attorneys, and other professionals, and all court or arbitration or other dispute resolution costs) arising out of or relating to any infringement of patent rights or copyrights incident to the use in the performance of the Work or resulting from the incorporation in the Work of any invention, design, process, product, or device specified in the Contract Documents, but not identified as being subject to payment of any license fee or royalty to others required by patent rights or copyrights.
- C. To the fullest extent permitted by Laws and Regulations, Contractor shall indemnify and hold harmless Owner and Engineer, and the officers, directors, members, partners, employees, agents, consultants and subcontractors of each and any of them from and against all claims, costs, losses, and damages (including but not limited to all fees and charges of engineers, architects, attorneys, and other professionals and all court or arbitration or other dispute resolution costs) arising out of or relating to any infringement of patent rights or copyrights incident to the use in the performance of the Work or resulting from the incorporation in the Work of any invention, design, process, product, or device not specified in the Contract Documents.

#### 7.08 *Permits*

- A. Unless otherwise provided in the Contract Documents, Contractor shall obtain and pay for all construction permits and licenses. Owner shall assist Contractor, when necessary, in obtaining such permits and licenses. Contractor shall pay all governmental charges and inspection fees necessary for the prosecution of the Work which are applicable at the time of the submission of Contractor's Bid (or when Contractor became bound under a negotiated contract). Owner shall pay all charges of utility owners for connections for providing permanent service to the Work

#### 7.09 *Taxes*

- A. Contractor shall pay all sales, consumer, use, and other similar taxes required to be paid by Contractor in accordance with the Laws and Regulations of the place of the Project which are applicable during the performance of the Work.

#### 7.10 *Laws and Regulations*

- A. Contractor shall give all notices required by and shall comply with all Laws and Regulations applicable to the performance of the Work. Except where otherwise expressly required by applicable Laws and Regulations, neither Owner nor Engineer shall be responsible for monitoring Contractor's compliance with any Laws or Regulations.
- B. If Contractor performs any Work or takes any other action knowing or having reason to know that it is contrary to Laws or Regulations, Contractor shall bear all resulting costs and losses, and shall indemnify and hold harmless Owner and Engineer, and the officers, directors, members, partners, employees, agents, consultants, and subcontractors of each and any of them from and against all claims, costs, losses, and damages (including but not limited to all fees and charges of engineers, architects, attorneys, and other professionals and all court or arbitration or other dispute resolution costs) arising out of or relating to such Work or other action. It shall not be Contractor's responsibility to make certain that the Work described in the Contract Documents is in accordance with Laws and Regulations, but this shall not relieve Contractor of Contractor's obligations under Paragraph 3.03.
- C. Owner or Contractor may give notice to the other party of any changes after the submission of Contractor's Bid (or after the date when Contractor became bound under a negotiated contract) in Laws or Regulations having an effect on the cost or time of performance of the Work, including but not limited to changes in Laws or Regulations having an effect on procuring permits and on sales, use, value-added, consumption, and other similar taxes. If Owner and Contractor are unable to agree on entitlement to or on the amount or extent, if any, of any adjustment in Contract Price or Contract Times resulting from such changes, then within 30 days of such notice Contractor may submit a Change Proposal, or Owner may initiate a Claim.

#### 7.11 *Record Documents*

- A. Contractor shall maintain in a safe place at the Site one printed record copy of all Drawings, Specifications, Addenda, Change Orders, Work Change Directives, Field Orders, written interpretations and clarifications, and approved Shop Drawings. Contractor shall keep such record documents in good order and annotate them to

show changes made during construction. These record documents, together with all approved Samples, will be available to Engineer for reference. Upon completion of the Work, Contractor shall deliver these record documents to Engineer.

#### 7.12 *Safety and Protection*

- A. Contractor shall be solely responsible for initiating, maintaining, and supervising all safety precautions and programs in connection with the Work. Such responsibility does not relieve Subcontractors of their responsibility for the safety of persons or property in the performance of their work, nor for compliance with applicable safety Laws and Regulations. Contractor shall take all necessary precautions for the safety of, and shall provide the necessary protection to prevent damage, injury, or loss to:
  - 1. all persons on the Site or who may be affected by the Work;
  - 2. all the Work and materials and equipment to be incorporated therein, whether in storage on or off the Site; and
  - 3. other property at the Site or adjacent thereto, including trees, shrubs, lawns, walks, pavements, roadways, structures, other work in progress, utilities, and Underground Facilities not designated for removal, relocation, or replacement in the course of construction.
- B. Contractor shall comply with all applicable Laws and Regulations relating to the safety of persons or property, or to the protection of persons or property from damage, injury, or loss; and shall erect and maintain all necessary safeguards for such safety and protection. Contractor shall notify Owner; the owners of adjacent property, Underground Facilities, and other utilities; and other contractors and utility owners performing work at or adjacent to the Site, when prosecution of the Work may affect them, and shall cooperate with them in the protection, removal, relocation, and replacement of their property or work in progress.
- C. Contractor shall comply with the applicable requirements of Owner's safety programs, if any. The Supplementary Conditions identify any Owner's safety programs that are applicable to the Work.
- D. Contractor shall inform Owner and Engineer of the specific requirements of Contractor's safety program with which Owner's and Engineer's employees and representatives must comply while at the Site.
- E. All damage, injury, or loss to any property referred to in Paragraph 7.12.A.2 or 7.12.A.3 caused, directly or indirectly, in whole or in part, by Contractor, any Subcontractor, Supplier, or any other individual or entity directly or indirectly employed by any of them to perform any of the Work, or anyone for whose acts any of them may be liable, shall be remedied by Contractor at its expense (except damage or loss attributable to the fault of Drawings or Specifications or to the acts or omissions of Owner or Engineer or anyone employed by any of them, or anyone for whose acts any of them may be liable, and not attributable, directly or indirectly, in whole or in part, to the fault or negligence of Contractor or any Subcontractor, Supplier, or other individual or entity directly or indirectly employed by any of them).

- F. Contractor's duties and responsibilities for safety and protection shall continue until such time as all the Work is completed and Engineer has issued a notice to Owner and Contractor in accordance with Paragraph 15.06.B that the Work is acceptable (except as otherwise expressly provided in connection with Substantial Completion).
- G. Contractor's duties and responsibilities for safety and protection shall resume whenever Contractor or any Subcontractor or Supplier returns to the Site to fulfill warranty or correction obligations, or to conduct other tasks arising from the Contract Documents.

7.13 *Safety Representative*

- A. Contractor shall designate a qualified and experienced safety representative at the Site whose duties and responsibilities shall be the prevention of accidents and the maintaining and supervising of safety precautions and programs.

7.14 *Hazard Communication Programs*

- A. Contractor shall be responsible for coordinating any exchange of material safety data sheets or other hazard communication information required to be made available to or exchanged between or among employers at the Site in accordance with Laws or Regulations.

7.15 *Emergencies*

- A. In emergencies affecting the safety or protection of persons or the Work or property at the Site or adjacent thereto, Contractor is obligated to act to prevent threatened damage, injury, or loss. Contractor shall give Engineer prompt written notice if Contractor believes that any significant changes in the Work or variations from the Contract Documents have been caused thereby or are required as a result thereof. If Engineer determines that a change in the Contract Documents is required because of the action taken by Contractor in response to such an emergency, a Work Change Directive or Change Order will be issued.

7.16 *Shop Drawings, Samples, and Other Submittals*

A. *Shop Drawing and Sample Submittal Requirements:*

1. Before submitting a Shop Drawing or Sample, Contractor shall have:
  - a. reviewed and coordinated the Shop Drawing or Sample with other Shop Drawings and Samples and with the requirements of the Work and the Contract Documents;
  - b. determined and verified all field measurements, quantities, dimensions, specified performance and design criteria, installation requirements, materials, catalog numbers, and similar information with respect thereto;
  - c. determined and verified the suitability of all materials and equipment offered with respect to the indicated application, fabrication, shipping, handling, storage, assembly, and installation pertaining to the performance of the Work; and

- d. determined and verified all information relative to Contractor's responsibilities for means, methods, techniques, sequences, and procedures of construction, and safety precautions and programs incident thereto.
  2. Each submittal shall bear a stamp or specific written certification that Contractor has satisfied Contractor's obligations under the Contract Documents with respect to Contractor's review of that submittal, and that Contractor approves the submittal.
  3. With each submittal, Contractor shall give Engineer specific written notice of any variations that the Shop Drawing or Sample may have from the requirements of the Contract Documents. This notice shall be set forth in a written communication separate from the Shop Drawings or Sample submittal; and, in addition, in the case of Shop Drawings by a specific notation made on each Shop Drawing submitted to Engineer for review and approval of each such variation.
- B. *Submittal Procedures for Shop Drawings and Samples:* Contractor shall submit Shop Drawings and Samples to Engineer for review and approval in accordance with the accepted Schedule of Submittals. Each submittal will be identified as Engineer may require.
1. *Shop Drawings:*
    - a. Contractor shall submit the number of copies required in the Specifications.
    - b. Data shown on the Shop Drawings will be complete with respect to quantities, dimensions, specified performance and design criteria, materials, and similar data to show Engineer the services, materials, and equipment Contractor proposes to provide and to enable Engineer to review the information for the limited purposes required by Paragraph 7.16.D.
  2. *Samples:*
    - a. Contractor shall submit the number of Samples required in the Specifications.
    - b. Contractor shall clearly identify each Sample as to material, Supplier, pertinent data such as catalog numbers, the use for which intended and other data as Engineer may require to enable Engineer to review the submittal for the limited purposes required by Paragraph 7.16.D.
  3. Where a Shop Drawing or Sample is required by the Contract Documents or the Schedule of Submittals, any related Work performed prior to Engineer's review and approval of the pertinent submittal will be at the sole expense and responsibility of Contractor.
- C. *Other Submittals:* Contractor shall submit other submittals to Engineer in accordance with the accepted Schedule of Submittals, and pursuant to the applicable terms of the Specifications.

D. *Engineer's Review:*

1. Engineer will provide timely review of Shop Drawings and Samples in accordance with the Schedule of Submittals acceptable to Engineer. Engineer's review and approval will be only to determine if the items covered by the submittals will, after installation or incorporation in the Work, conform to the information given in the Contract Documents and be compatible with the design concept of the completed Project as a functioning whole as indicated by the Contract Documents.
2. Engineer's review and approval will not extend to means, methods, techniques, sequences, or procedures of construction or to safety precautions or programs incident thereto.
3. Engineer's review and approval of a separate item as such will not indicate approval of the assembly in which the item functions.
4. Engineer's review and approval of a Shop Drawing or Sample shall not relieve Contractor from responsibility for any variation from the requirements of the Contract Documents unless Contractor has complied with the requirements of Paragraph 7.16.A.3 and Engineer has given written approval of each such variation by specific written notation thereof incorporated in or accompanying the Shop Drawing or Sample. Engineer will document any such approved variation from the requirements of the Contract Documents in a Field Order.
5. Engineer's review and approval of a Shop Drawing or Sample shall not relieve Contractor from responsibility for complying with the requirements of Paragraph 7.16.A and B.
6. Engineer's review and approval of a Shop Drawing or Sample, or of a variation from the requirements of the Contract Documents, shall not, under any circumstances, change the Contract Times or Contract Price, unless such changes are included in a Change Order.
7. Neither Engineer's receipt, review, acceptance or approval of a Shop Drawing, Sample, or other submittal shall result in such item becoming a Contract Document.
8. Contractor shall perform the Work in compliance with the requirements and commitments set forth in approved Shop Drawings and Samples, subject to the provisions of Paragraph 7.16.D.4.

E. *Resubmittal Procedures:*

1. Contractor shall make corrections required by Engineer and shall return the required number of corrected copies of Shop Drawings and submit, as required, new Samples for review and approval. Contractor shall direct specific attention in writing to revisions other than the corrections called for by Engineer on previous submittals.
2. Contractor shall furnish required submittals with sufficient information and accuracy to obtain required approval of an item with no more than three submittals. Engineer will record Engineer's time for reviewing a fourth or



subsequent submittal of a Shop Drawings, sample, or other item requiring approval, and Contractor shall be responsible for Engineer's charges to Owner for such time. Owner may impose a set-off against payments due to Contractor to secure reimbursement for such charges.

3. If Contractor requests a change of a previously approved submittal item, Contractor shall be responsible for Engineer's charges to Owner for its review time, and Owner may impose a set-off against payments due to Contractor to secure reimbursement for such charges, unless the need for such change is beyond the control of Contractor.

7.17 *Contractor's General Warranty and Guarantee*

- A. Contractor warrants and guarantees to Owner that all Work will be in accordance with the Contract Documents and will not be defective. Engineer and its officers, directors, members, partners, employees, agents, consultants, and subcontractors shall be entitled to rely on Contractor's warranty and guarantee.
- B. Contractor's warranty and guarantee hereunder excludes defects or damage caused by:
  1. abuse, modification, or improper maintenance or operation by persons other than Contractor, Subcontractors, Suppliers, or any other individual or entity for whom Contractor is responsible; or
  2. normal wear and tear under normal usage.
- C. Contractor's obligation to perform and complete the Work in accordance with the Contract Documents shall be absolute. None of the following will constitute an acceptance of Work that is not in accordance with the Contract Documents or a release of Contractor's obligation to perform the Work in accordance with the Contract Documents:
  1. observations by Engineer;
  2. recommendation by Engineer or payment by Owner of any progress or final payment;
  3. the issuance of a certificate of Substantial Completion by Engineer or any payment related thereto by Owner;
  4. use or occupancy of the Work or any part thereof by Owner;
  5. any review and approval of a Shop Drawing or Sample submittal;
  6. the issuance of a notice of acceptability by Engineer;
  7. any inspection, test, or approval by others; or
  8. any correction of defective Work by Owner.
- D. If the Contract requires the Contractor to accept the assignment of a contract entered into by Owner, then the specific warranties, guarantees, and correction obligations contained in the assigned contract shall govern with respect to Contractor's performance obligations to Owner for the Work described in the assigned contract.

#### 7.18 *Indemnification*

- A. To the fullest extent permitted by Laws and Regulations, and in addition to any other obligations of Contractor under the Contract or otherwise, Contractor shall indemnify and hold harmless Owner and Engineer, and the officers, directors, members, partners, employees, agents, consultants and subcontractors of each and any of them from and against all claims, costs, losses, and damages (including but not limited to all fees and charges of engineers, architects, attorneys, and other professionals and all court or arbitration or other dispute resolution costs) arising out of or relating to the performance of the Work, provided that any such claim, cost, loss, or damage is attributable to bodily injury, sickness, disease, or death, or to injury to or destruction of tangible property (other than the Work itself), including the loss of use resulting therefrom but only to the extent caused by any negligent act or omission of Contractor, any Subcontractor, any Supplier, or any individual or entity directly or indirectly employed by any of them to perform any of the Work or anyone for whose acts any of them may be liable.
- B. In any and all claims against Owner or Engineer or any of their officers, directors, members, partners, employees, agents, consultants, or subcontractors by any employee (or the survivor or personal representative of such employee) of Contractor, any Subcontractor, any Supplier, or any individual or entity directly or indirectly employed by any of them to perform any of the Work, or anyone for whose acts any of them may be liable, the indemnification obligation under Paragraph 7.18.A shall not be limited in any way by any limitation on the amount or type of damages, compensation, or benefits payable by or for Contractor or any such Subcontractor, Supplier, or other individual or entity under workers' compensation acts, disability benefit acts, or other employee benefit acts.
- C. The indemnification obligations of Contractor under Paragraph 7.18.A shall not extend to the liability of Engineer and Engineer's officers, directors, members, partners, employees, agents, consultants and subcontractors arising out of:
  - 1. the preparation or approval of, or the failure to prepare or approve maps, Drawings, opinions, reports, surveys, Change Orders, designs, or Specifications; or
  - 2. giving directions or instructions, or failing to give them, if that is the primary cause of the injury or damage.

#### 7.19 *Delegation of Professional Design Services*

- A. Contractor will not be required to provide professional design services unless such services are specifically required by the Contract Documents for a portion of the Work or unless such services are required to carry out Contractor's responsibilities for construction means, methods, techniques, sequences and procedures. Contractor shall not be required to provide professional services in violation of applicable Laws and Regulations.
- B. If professional design services or certifications by a design professional related to systems, materials, or equipment are specifically required of Contractor by the Contract Documents, Owner and Engineer will specify all performance and design

criteria that such services must satisfy. Contractor shall cause such services or certifications to be provided by a properly licensed professional, whose signature and seal shall appear on all drawings, calculations, specifications, certifications, and other submittals prepared by such professional. Shop Drawings and other submittals related to the Work designed or certified by such professional, if prepared by others, shall bear such professional's written approval when submitted to Engineer.

- C. Owner and Engineer shall be entitled to rely upon the adequacy, accuracy, and completeness of the services, certifications, or approvals performed by such design professionals, provided Owner and Engineer have specified to Contractor all performance and design criteria that such services must satisfy.
- D. Pursuant to this paragraph, Engineer's review and approval of design calculations and design drawings will be only for the limited purpose of checking for conformance with performance and design criteria given and the design concept expressed in the Contract Documents. Engineer's review and approval of Shop Drawings and other submittals (except design calculations and design drawings) will be only for the purpose stated in Paragraph 7.16.D.1.
- E. Contractor shall not be responsible for the adequacy of the performance or design criteria specified by Owner or Engineer.

## **ARTICLE 8 – OTHER WORK AT THE SITE**

### **8.01 *Other Work***

- A. In addition to and apart from the Work under the Contract Documents, the Owner may perform other work at or adjacent to the Site. Such other work may be performed by Owner's employees, or through contracts between the Owner and third parties. Owner may also arrange to have third-party utility owners perform work on their utilities and facilities at or adjacent to the Site.
- B. If Owner performs other work at or adjacent to the Site with Owner's employees, or through contracts for such other work, then Owner shall give Contractor written notice thereof prior to starting any such other work. If Owner has advance information regarding the start of any utility work at or adjacent to the Site, Owner shall provide such information to Contractor.
- C. Contractor shall afford each other contractor that performs such other work, each utility owner performing other work, and Owner, if Owner is performing other work with Owner's employees, proper and safe access to the Site, and provide a reasonable opportunity for the introduction and storage of materials and equipment and the execution of such other work. Contractor shall do all cutting, fitting, and patching of the Work that may be required to properly connect or otherwise make its several parts come together and properly integrate with such other work. Contractor shall not endanger any work of others by cutting, excavating, or otherwise altering such work; provided, however, that Contractor may cut or alter others' work with the written consent of Engineer and the others whose work will be affected.
- D. If the proper execution or results of any part of Contractor's Work depends upon work performed by others under this Article 8, Contractor shall inspect such other

work and promptly report to Engineer in writing any delays, defects, or deficiencies in such other work that render it unavailable or unsuitable for the proper execution and results of Contractor's Work. Contractor's failure to so report will constitute an acceptance of such other work as fit and proper for integration with Contractor's Work except for latent defects and deficiencies in such other work.

#### 8.02 *Coordination*

- A. If Owner intends to contract with others for the performance of other work at or adjacent to the Site, to perform other work at or adjacent to the Site with Owner's employees, or to arrange to have utility owners perform work at or adjacent to the Site, the following will be set forth in the Supplementary Conditions or provided to Contractor prior to the start of any such other work:
  - 1. the identity of the individual or entity that will have authority and responsibility for coordination of the activities among the various contractors;
  - 2. an itemization of the specific matters to be covered by such authority and responsibility; and
  - 3. the extent of such authority and responsibilities.
- B. Unless otherwise provided in the Supplementary Conditions, Owner shall have sole authority and responsibility for such coordination.

#### 8.03 *Legal Relationships*

- A. If, in the course of performing other work at or adjacent to the Site for Owner, the Owner's employees, any other contractor working for Owner, or any utility owner for whom the Owner is responsible causes damage to the Work or to the property of Contractor or its Subcontractors, or delays, disrupts, interferes with, or increases the scope or cost of the performance of the Work, through actions or inaction, then Contractor shall be entitled to an equitable adjustment in the Contract Price or the Contract Times, or both. Contractor must submit any Change Proposal seeking an equitable adjustment in the Contract Price or the Contract Times under this paragraph within 30 days of the damaging, delaying, disrupting, or interfering event. The entitlement to, and extent of, any such equitable adjustment shall take into account information (if any) regarding such other work that was provided to Contractor in the Contract Documents prior to the submittal of the Bid or the final negotiation of the terms of the Contract. When applicable, any such equitable adjustment in Contract Price shall be conditioned on Contractor assigning to Owner all Contractor's rights against such other contractor or utility owner with respect to the damage, delay, disruption, or interference that is the subject of the adjustment. Contractor's entitlement to an adjustment of the Contract Times is conditioned on such adjustment being essential to Contractor's ability to complete the Work within the Contract Times.
- B. Contractor shall take reasonable and customary measures to avoid damaging, delaying, disrupting, or interfering with the work of Owner, any other contractor, or any utility owner performing other work at or adjacent to the Site. If Contractor fails to take such measures and as a result damages, delays, disrupts, or interferes with the work of any such other contractor or utility owner, then Owner may impose a set-off

against payments due to Contractor, and assign to such other contractor or utility owner the Owner's contractual rights against Contractor with respect to the breach of the obligations set forth in this paragraph.

- C. When Owner is performing other work at or adjacent to the Site with Owner's employees, Contractor shall be liable to Owner for damage to such other work, and for the reasonable direct delay, disruption, and interference costs incurred by Owner as a result of Contractor's failure to take reasonable and customary measures with respect to Owner's other work. In response to such damage, delay, disruption, or interference, Owner may impose a set-off against payments due to Contractor.
- D. If Contractor damages, delays, disrupts, or interferes with the work of any other contractor, or any utility owner performing other work at or adjacent to the Site, through Contractor's failure to take reasonable and customary measures to avoid such impacts, or if any claim arising out of Contractor's actions, inactions, or negligence in performance of the Work at or adjacent to the Site is made by any such other contractor or utility owner against Contractor, Owner, or Engineer, then Contractor shall (1) promptly attempt to settle the claim as to all parties through negotiations with such other contractor or utility owner, or otherwise resolve the claim by arbitration or other dispute resolution proceeding or at law, and (2) indemnify and hold harmless Owner and Engineer, and the officers, directors, members, partners, employees, agents, consultants and subcontractors of each and any of them from and against any such claims, and against all costs, losses, and damages (including but not limited to all fees and charges of engineers, architects, attorneys, and other professionals and all court or arbitration or other dispute resolution costs) arising out of or relating to such damage, delay, disruption, or interference.

## **ARTICLE 9 – OWNER'S RESPONSIBILITIES**

### *9.01 Communications to Contractor*

- A. Except as otherwise provided in these General Conditions, Owner shall issue all communications to Contractor through Engineer.

### *9.02 Replacement of Engineer*

- A. Owner may at its discretion appoint an engineer to replace Engineer, provided Contractor makes no reasonable objection to the replacement engineer. The replacement engineer's status under the Contract Documents shall be that of the former Engineer.

### *9.03 Furnish Data*

- A. Owner shall promptly furnish the data required of Owner under the Contract Documents.

### *9.04 Pay When Due*

- A. Owner shall make payments to Contractor when they are due as provided in the Agreement.

9.05 *Lands and Easements; Reports, Tests, and Drawings*

- A. Owner's duties with respect to providing lands and easements are set forth in Paragraph 5.01.
- B. Owner's duties with respect to providing engineering surveys to establish reference points are set forth in Paragraph 4.03.
- C. Article 5 refers to Owner's identifying and making available to Contractor copies of reports of explorations and tests of conditions at the Site, and drawings of physical conditions relating to existing surface or subsurface structures at the Site.

9.06 *Insurance*

- A. Owner's responsibilities, if any, with respect to purchasing and maintaining liability and property insurance are set forth in Article 6.

9.07 *Change Orders*

- A. Owner's responsibilities with respect to Change Orders are set forth in Article 11.

9.08 *Inspections, Tests, and Approvals*

- A. Owner's responsibility with respect to certain inspections, tests, and approvals is set forth in Paragraph 14.02.B.

9.09 *Limitations on Owner's Responsibilities*

- A. The Owner shall not supervise, direct, or have control or authority over, nor be responsible for, Contractor's means, methods, techniques, sequences, or procedures of construction, or the safety precautions and programs incident thereto, or for any failure of Contractor to comply with Laws and Regulations applicable to the performance of the Work. Owner will not be responsible for Contractor's failure to perform the Work in accordance with the Contract Documents.

9.10 *Undisclosed Hazardous Environmental Condition*

- A. Owner's responsibility in respect to an undisclosed Hazardous Environmental Condition is set forth in Paragraph 5.06.

9.11 *Evidence of Financial Arrangements*

- A. Upon request of Contractor, Owner shall furnish Contractor reasonable evidence that financial arrangements have been made to satisfy Owner's obligations under the Contract Documents (including obligations under proposed changes in the Work).

9.12 *Safety Programs*

- A. While at the Site, Owner's employees and representatives shall comply with the specific applicable requirements of Contractor's safety programs of which Owner has been informed.
- B. Owner shall furnish copies of any applicable Owner safety programs to Contractor.

## **ARTICLE 10 – ENGINEER’S STATUS DURING CONSTRUCTION**

### *10.01 Owner’s Representative*

- A. Engineer will be Owner’s representative during the construction period. The duties and responsibilities and the limitations of authority of Engineer as Owner’s representative during construction are set forth in the Contract.

### *10.02 Visits to Site*

- A. Engineer will make visits to the Site at intervals appropriate to the various stages of construction as Engineer deems necessary in order to observe as an experienced and qualified design professional the progress that has been made and the quality of the various aspects of Contractor’s executed Work. Based on information obtained during such visits and observations, Engineer, for the benefit of Owner, will determine, in general, if the Work is proceeding in accordance with the Contract Documents. Engineer will not be required to make exhaustive or continuous inspections on the Site to check the quality or quantity of the Work. Engineer’s efforts will be directed toward providing for Owner a greater degree of confidence that the completed Work will conform generally to the Contract Documents. On the basis of such visits and observations, Engineer will keep Owner informed of the progress of the Work and will endeavor to guard Owner against defective Work.
- B. Engineer’s visits and observations are subject to all the limitations on Engineer’s authority and responsibility set forth in Paragraph 10.08. Particularly, but without limitation, during or as a result of Engineer’s visits or observations of Contractor’s Work, Engineer will not supervise, direct, control, or have authority over or be responsible for Contractor’s means, methods, techniques, sequences, or procedures of construction, or the safety precautions and programs incident thereto, or for any failure of Contractor to comply with Laws and Regulations applicable to the performance of the Work.

### *10.03 Project Representative*

- A. If Owner and Engineer have agreed that Engineer will furnish a Resident Project Representative to represent Engineer at the Site and assist Engineer in observing the progress and quality of the Work, then the authority and responsibilities of any such Resident Project Representative will be as provided in the Supplementary Conditions, and limitations on the responsibilities thereof will be as provided in Paragraph 10.08. If Owner designates another representative or agent to represent Owner at the Site who is not Engineer’s consultant, agent, or employee, the responsibilities and authority and limitations thereon of such other individual or entity will be as provided in the Supplementary Conditions.

### *10.04 Rejecting Defective Work*

- A. Engineer has the authority to reject Work in accordance with Article 14.

### *10.05 Shop Drawings, Change Orders and Payments*

- A. Engineer’s authority, and limitations thereof, as to Shop Drawings and Samples, are set forth in Paragraph 7.16.

- B. Engineer's authority, and limitations thereof, as to design calculations and design drawings submitted in response to a delegation of professional design services, if any, are set forth in Paragraph 7.19.
- C. Engineer's authority as to Change Orders is set forth in Article 11.
- D. Engineer's authority as to Applications for Payment is set forth in Article 15.

10.06 *Determinations for Unit Price Work*

- A. Engineer will determine the actual quantities and classifications of Unit Price Work performed by Contractor as set forth in Paragraph 13.03.

10.07 *Decisions on Requirements of Contract Documents and Acceptability of Work*

- A. Engineer will render decisions regarding the requirements of the Contract Documents, and judge the acceptability of the Work, pursuant to the specific procedures set forth herein for initial interpretations, Change Proposals, and acceptance of the Work. In rendering such decisions and judgments, Engineer will not show partiality to Owner or Contractor, and will not be liable to Owner, Contractor, or others in connection with any proceedings, interpretations, decisions, or judgments conducted or rendered in good faith.

10.08 *Limitations on Engineer's Authority and Responsibilities*

- A. Neither Engineer's authority or responsibility under this Article 10 or under any other provision of the Contract, nor any decision made by Engineer in good faith either to exercise or not exercise such authority or responsibility or the undertaking, exercise, or performance of any authority or responsibility by Engineer, shall create, impose, or give rise to any duty in contract, tort, or otherwise owed by Engineer to Contractor, any Subcontractor, any Supplier, any other individual or entity, or to any surety for or employee or agent of any of them.
- B. Engineer will not supervise, direct, control, or have authority over or be responsible for Contractor's means, methods, techniques, sequences, or procedures of construction, or the safety precautions and programs incident thereto, or for any failure of Contractor to comply with Laws and Regulations applicable to the performance of the Work. Engineer will not be responsible for Contractor's failure to perform the Work in accordance with the Contract Documents.
- C. Engineer will not be responsible for the acts or omissions of Contractor or of any Subcontractor, any Supplier, or of any other individual or entity performing any of the Work.
- D. Engineer's review of the final Application for Payment and accompanying documentation and all maintenance and operating instructions, schedules, guarantees, bonds, certificates of inspection, tests and approvals, and other documentation required to be delivered by Paragraph 15.06.A will only be to determine generally that their content complies with the requirements of, and in the case of certificates of inspections, tests, and approvals, that the results certified indicate compliance with the Contract Documents.



- E. The limitations upon authority and responsibility set forth in this Paragraph 10.08 shall also apply to the Resident Project Representative, if any.

10.09 *Compliance with Safety Program*

- A. While at the Site, Engineer's employees and representatives will comply with the specific applicable requirements of Owner's and Contractor's safety programs (if any) of which Engineer has been informed.

**ARTICLE 11 – AMENDING THE CONTRACT DOCUMENTS; CHANGES IN THE WORK**

11.01 *Amending and Supplementing Contract Documents*

- A. The Contract Documents may be amended or supplemented by a Change Order, a Work Change Directive, or a Field Order.

1. *Change Orders:*

- a. If an amendment or supplement to the Contract Documents includes a change in the Contract Price or the Contract Times, such amendment or supplement must be set forth in a Change Order. A Change Order also may be used to establish amendments and supplements of the Contract Documents that do not affect the Contract Price or Contract Times.
- b. Owner and Contractor may amend those terms and conditions of the Contract Documents that do not involve (1) the performance or acceptability of the Work, (2) the design (as set forth in the Drawings, Specifications, or otherwise), or (3) other engineering or technical matters, without the recommendation of the Engineer. Such an amendment shall be set forth in a Change Order.

- 2. *Work Change Directives:* A Work Change Directive will not change the Contract Price or the Contract Times but is evidence that the parties expect that the modification ordered or documented by a Work Change Directive will be incorporated in a subsequently issued Change Order, following negotiations by the parties as to the Work Change Directive's effect, if any, on the Contract Price and Contract Times; or, if negotiations are unsuccessful, by a determination under the terms of the Contract Documents governing adjustments, expressly including Paragraph 11.04 regarding change of Contract Price. Contractor must submit any Change Proposal seeking an adjustment of the Contract Price or the Contract Times, or both, no later than 30 days after the completion of the Work set out in the Work Change Directive. Owner must submit any Claim seeking an adjustment of the Contract Price or the Contract Times, or both, no later than 60 days after issuance of the Work Change Directive.

- 3. *Field Orders:* Engineer may authorize minor changes in the Work if the changes do not involve an adjustment in the Contract Price or the Contract Times and are compatible with the design concept of the completed Project as a functioning whole as indicated by the Contract Documents. Such changes will be

accomplished by a Field Order and will be binding on Owner and also on Contractor, which shall perform the Work involved promptly. If Contractor believes that a Field Order justifies an adjustment in the Contract Price or Contract Times, or both, then before proceeding with the Work at issue, Contractor shall submit a Change Proposal as provided herein.

#### 11.02 *Owner-Authorized Changes in the Work*

- A. Without invalidating the Contract and without notice to any surety, Owner may, at any time or from time to time, order additions, deletions, or revisions in the Work. Such changes shall be supported by Engineer's recommendation, to the extent the change involves the design (as set forth in the Drawings, Specifications, or otherwise), or other engineering or technical matters. Such changes may be accomplished by a Change Order, if Owner and Contractor have agreed as to the effect, if any, of the changes on Contract Times or Contract Price; or by a Work Change Directive. Upon receipt of any such document, Contractor shall promptly proceed with the Work involved; or, in the case of a deletion in the Work, promptly cease construction activities with respect to such deleted Work. Added or revised Work shall be performed under the applicable conditions of the Contract Documents. Nothing in this paragraph shall obligate Contractor to undertake work that Contractor reasonably concludes cannot be performed in a manner consistent with Contractor's safety obligations under the Contract Documents or Laws and Regulations.

#### 11.03 *Unauthorized Changes in the Work*

- A. Contractor shall not be entitled to an increase in the Contract Price or an extension of the Contract Times with respect to any work performed that is not required by the Contract Documents, as amended, modified, or supplemented, except in the case of an emergency as provided in Paragraph 7.15 or in the case of uncovering Work as provided in Paragraph 14.05.

#### 11.04 *Change of Contract Price*

- A. The Contract Price may only be changed by a Change Order. Any Change Proposal for an adjustment in the Contract Price shall comply with the provisions of Paragraph 11.06. Any Claim for an adjustment of Contract Price shall comply with the provisions of Article 12.
- B. An adjustment in the Contract Price will be determined as follows:
1. where the Work involved is covered by unit prices contained in the Contract Documents, then by application of such unit prices to the quantities of the items involved (subject to the provisions of Paragraph 13.03); or
  2. where the Work involved is not covered by unit prices contained in the Contract Documents, then by a mutually agreed lump sum (which may include an allowance for overhead and profit not necessarily in accordance with Paragraph 11.04.C.2); or
  3. where the Work involved is not covered by unit prices contained in the Contract Documents and the parties do not reach mutual agreement to a lump sum, then on the basis of the Cost of the Work (determined as provided in Paragraph

13.01) plus a Contractor's fee for overhead and profit (determined as provided in Paragraph 11.04.C).

- C. *Contractor's Fee*: When applicable, the Contractor's fee for overhead and profit shall be determined as follows:
1. a mutually acceptable fixed fee; or
  2. if a fixed fee is not agreed upon, then a fee based on the following percentages of the various portions of the Cost of the Work:
    - a. for costs incurred under Paragraphs 13.01.B.1 and 13.01.B.2, the Contractor's fee shall be 15 percent;
    - b. for costs incurred under Paragraph 13.01.B.3, the Contractor's fee shall be five percent;
    - c. where one or more tiers of subcontracts are on the basis of Cost of the Work plus a fee and no fixed fee is agreed upon, the intent of Paragraphs 11.04.C.2.a and 11.04.C.2.b is that the Contractor's fee shall be based on: (1) a fee of 15 percent of the costs incurred under Paragraphs 13.01.A.1 and 13.01.A.2 by the Subcontractor that actually performs the Work, at whatever tier, and (2) with respect to Contractor itself and to any Subcontractors of a tier higher than that of the Subcontractor that actually performs the Work, a fee of five percent of the amount (fee plus underlying costs incurred) attributable to the next lower tier Subcontractor; provided, however, that for any such subcontracted work the maximum total fee to be paid by Owner shall be no greater than 27 percent of the costs incurred by the Subcontractor that actually performs the work;
    - d. no fee shall be payable on the basis of costs itemized under Paragraphs 13.01.B.4, 13.01.B.5, and 13.01.C;
    - e. the amount of credit to be allowed by Contractor to Owner for any change which results in a net decrease in cost will be the amount of the actual net decrease in cost plus a deduction in Contractor's fee by an amount equal to five percent of such net decrease; and
    - f. when both additions and credits are involved in any one change, the adjustment in Contractor's fee shall be computed on the basis of the net change in accordance with Paragraphs 11.04.C.2.a through 11.04.C.2.e, inclusive.

#### 11.05 *Change of Contract Times*

- A. The Contract Times may only be changed by a Change Order. Any Change Proposal for an adjustment in the Contract Times shall comply with the provisions of Paragraph 11.06. Any Claim for an adjustment in the Contract Times shall comply with the provisions of Article 12.
- B. An adjustment of the Contract Times shall be subject to the limitations set forth in Paragraph 4.05, concerning delays in Contractor's progress.

## 11.06 *Change Proposals*

- A. Contractor shall submit a Change Proposal to Engineer to request an adjustment in the Contract Times or Contract Price; appeal an initial decision by Engineer concerning the requirements of the Contract Documents or relating to the acceptability of the Work under the Contract Documents; contest a set-off against payment due; or seek other relief under the Contract. The Change Proposal shall specify any proposed change in Contract Times or Contract Price, or both, or other proposed relief, and explain the reason for the proposed change, with citations to any governing or applicable provisions of the Contract Documents.
1. *Procedures:* Contractor shall submit each Change Proposal to Engineer promptly (but in no event later than 30 days) after the start of the event giving rise thereto, or after such initial decision. The Contractor shall submit supporting data, including the proposed change in Contract Price or Contract Time (if any), to the Engineer and Owner within 15 days after the submittal of the Change Proposal. The supporting data shall be accompanied by a written statement that the supporting data are accurate and complete, and that any requested time or price adjustment is the entire adjustment to which Contractor believes it is entitled as a result of said event. Engineer will advise Owner regarding the Change Proposal, and consider any comments or response from Owner regarding the Change Proposal.
  2. *Engineer's Action:* Engineer will review each Change Proposal and, within 30 days after receipt of the Contractor's supporting data, either deny the Change Proposal in whole, approve it in whole, or deny it in part and approve it in part. Such actions shall be in writing, with a copy provided to Owner and Contractor. If Engineer does not take action on the Change Proposal within 30 days, then either Owner or Contractor may at any time thereafter submit a letter to the other party indicating that as a result of Engineer's inaction the Change Proposal is deemed denied, thereby commencing the time for appeal of the denial under Article 12.
  3. *Binding Decision:* Engineer's decision will be final and binding upon Owner and Contractor, unless Owner or Contractor appeals the decision by filing a Claim under Article 12.
- B. *Resolution of Certain Change Proposals:* If the Change Proposal does not involve the design (as set forth in the Drawings, Specifications, or otherwise), the acceptability of the Work, or other engineering or technical matters, then Engineer will notify the parties that the Engineer is unable to resolve the Change Proposal. For purposes of further resolution of such a Change Proposal, such notice shall be deemed a denial, and Contractor may choose to seek resolution under the terms of Article 12.

### 11.07 *Execution of Change Orders*

- A. Owner and Contractor shall execute appropriate Change Orders covering:
1. changes in the Contract Price or Contract Times which are agreed to by the parties, including any undisputed sum or amount of time for Work actually performed in accordance with a Work Change Directive;
  2. changes in Contract Price resulting from an Owner set-off, unless Contractor has duly contested such set-off;
  3. changes in the Work which are: (a) ordered by Owner pursuant to Paragraph 11.02, (b) required because of Owner's acceptance of defective Work under Paragraph 14.04 or Owner's correction of defective Work under Paragraph 14.07, or (c) agreed to by the parties, subject to the need for Engineer's recommendation if the change in the Work involves the design (as set forth in the Drawings, Specifications, or otherwise), or other engineering or technical matters; and
  4. changes in the Contract Price or Contract Times, or other changes, which embody the substance of any final and binding results under Paragraph 11.06, or Article 12.
- B. If Owner or Contractor refuses to execute a Change Order that is required to be executed under the terms of this Paragraph 11.07, it shall be deemed to be of full force and effect, as if fully executed.

### 11.08 *Notification to Surety*

- A. If the provisions of any bond require notice to be given to a surety of any change affecting the general scope of the Work or the provisions of the Contract Documents (including, but not limited to, Contract Price or Contract Times), the giving of any such notice will be Contractor's responsibility. The amount of each applicable bond will be adjusted to reflect the effect of any such change.

## **ARTICLE 12 – CLAIMS**

### 12.01 *Claims*

- A. *Claims Process:* The following disputes between Owner and Contractor shall be submitted to the Claims process set forth in this Article:
1. Appeals by Owner or Contractor of Engineer's decisions regarding Change Proposals;
  2. Owner demands for adjustments in the Contract Price or Contract Times, or other relief under the Contract Documents; and
  3. Disputes that Engineer has been unable to address because they do not involve the design (as set forth in the Drawings, Specifications, or otherwise), the acceptability of the Work, or other engineering or technical matters.
- B. *Submittal of Claim:* The party submitting a Claim shall deliver it directly to the other party to the Contract promptly (but in no event later than 30 days) after the start of

the event giving rise thereto; in the case of appeals regarding Change Proposals within 30 days of the decision under appeal. The party submitting the Claim shall also furnish a copy to the Engineer, for its information only. The responsibility to substantiate a Claim shall rest with the party making the Claim. In the case of a Claim by Contractor seeking an increase in the Contract Times or Contract Price, or both, Contractor shall certify that the Claim is made in good faith, that the supporting data are accurate and complete, and that to the best of Contractor's knowledge and belief the amount of time or money requested accurately reflects the full amount to which Contractor is entitled.

- C. *Review and Resolution:* The party receiving a Claim shall review it thoroughly, giving full consideration to its merits. The two parties shall seek to resolve the Claim through the exchange of information and direct negotiations. The parties may extend the time for resolving the Claim by mutual agreement. All actions taken on a Claim shall be stated in writing and submitted to the other party, with a copy to Engineer.
- D. *Mediation:*
  - 1. At any time after initiation of a Claim, Owner and Contractor may mutually agree to mediation of the underlying dispute. The agreement to mediate shall stay the Claim submittal and response process.
  - 2. If Owner and Contractor agree to mediation, then after 60 days from such agreement, either Owner or Contractor may unilaterally terminate the mediation process, and the Claim submittal and decision process shall resume as of the date of the termination. If the mediation proceeds but is unsuccessful in resolving the dispute, the Claim submittal and decision process shall resume as of the date of the conclusion of the mediation, as determined by the mediator.
  - 3. Owner and Contractor shall each pay one-half of the mediator's fees and costs.
- E. *Partial Approval:* If the party receiving a Claim approves the Claim in part and denies it in part, such action shall be final and binding unless within 30 days of such action the other party invokes the procedure set forth in Article 17 for final resolution of disputes.
- F. *Denial of Claim:* If efforts to resolve a Claim are not successful, the party receiving the Claim may deny it by giving written notice of denial to the other party. If the receiving party does not take action on the Claim within 90 days, then either Owner or Contractor may at any time thereafter submit a letter to the other party indicating that as a result of the inaction, the Claim is deemed denied, thereby commencing the time for appeal of the denial. A denial of the Claim shall be final and binding unless within 30 days of the denial the other party invokes the procedure set forth in Article 17 for the final resolution of disputes.
- G. *Final and Binding Results:* If the parties reach a mutual agreement regarding a Claim, whether through approval of the Claim, direct negotiations, mediation, or otherwise; or if a Claim is approved in part and denied in part, or denied in full, and such actions become final and binding; then the results of the agreement or action on the Claim shall be incorporated in a Change Order to the extent they affect the Contract, including the Work, the Contract Times, or the Contract Price.

## **ARTICLE 13 – COST OF THE WORK; ALLOWANCES; UNIT PRICE WORK**

### *13.01 Cost of the Work*

- A. *Purposes for Determination of Cost of the Work:* The term Cost of the Work means the sum of all costs necessary for the proper performance of the Work at issue, as further defined below. The provisions of this Paragraph 13.01 are used for two distinct purposes:
1. To determine Cost of the Work when Cost of the Work is a component of the Contract Price, under cost-plus-fee, time-and-materials, or other cost-based terms; or
  2. To determine the value of a Change Order, Change Proposal, Claim, set-off, or other adjustment in Contract Price. When the value of any such adjustment is determined on the basis of Cost of the Work, Contractor is entitled only to those additional or incremental costs required because of the change in the Work or because of the event giving rise to the adjustment.
- B. *Costs Included:* Except as otherwise may be agreed to in writing by Owner, costs included in the Cost of the Work shall be in amounts no higher than those prevailing in the locality of the Project, shall not include any of the costs itemized in Paragraph 13.01.C, and shall include only the following items:
1. Payroll costs for employees in the direct employ of Contractor in the performance of the Work under schedules of job classifications agreed upon by Owner and Contractor. Such employees shall include, without limitation, superintendents, foremen, and other personnel employed full time on the Work. Payroll costs for employees not employed full time on the Work shall be apportioned on the basis of their time spent on the Work. Payroll costs shall include, but not be limited to, salaries and wages plus the cost of fringe benefits, which shall include social security contributions, unemployment, excise, and payroll taxes, workers' compensation, health and retirement benefits, bonuses, sick leave, and vacation and holiday pay applicable thereto. The expenses of performing Work outside of regular working hours, on Saturday, Sunday, or legal holidays, shall be included in the above to the extent authorized by Owner.
  2. Cost of all materials and equipment furnished and incorporated in the Work, including costs of transportation and storage thereof, and Suppliers' field services required in connection therewith. All cash discounts shall accrue to Contractor unless Owner deposits funds with Contractor with which to make payments, in which case the cash discounts shall accrue to Owner. All trade discounts, rebates, and refunds and returns from sale of surplus materials and equipment shall accrue to Owner, and Contractor shall make provisions so that they may be obtained.
  3. Payments made by Contractor to Subcontractors for Work performed by Subcontractors. If required by Owner, Contractor shall obtain competitive bids from subcontractors acceptable to Owner and Contractor and shall deliver such bids to Owner, who will then determine, with the advice of Engineer, which bids, if any, will be acceptable. If any subcontract provides that the

Subcontractor is to be paid on the basis of Cost of the Work plus a fee, the Subcontractor's Cost of the Work and fee shall be determined in the same manner as Contractor's Cost of the Work and fee as provided in this Paragraph 13.01.

4. Costs of special consultants (including but not limited to engineers, architects, testing laboratories, surveyors, attorneys, and accountants) employed for services specifically related to the Work.
5. Supplemental costs including the following:
  - a. The proportion of necessary transportation, travel, and subsistence expenses of Contractor's employees incurred in discharge of duties connected with the Work.
  - b. Cost, including transportation and maintenance, of all materials, supplies, equipment, machinery, appliances, office, and temporary facilities at the Site, and hand tools not owned by the workers, which are consumed in the performance of the Work, and cost, less market value, of such items used but not consumed which remain the property of Contractor.
  - c. Rentals of all construction equipment and machinery, and the parts thereof, whether rented from Contractor or others in accordance with rental agreements approved by Owner with the advice of Engineer, and the costs of transportation, loading, unloading, assembly, dismantling, and removal thereof. All such costs shall be in accordance with the terms of said rental agreements. The rental of any such equipment, machinery, or parts shall cease when the use thereof is no longer necessary for the Work.
  - d. Sales, consumer, use, and other similar taxes related to the Work, and for which Contractor is liable, as imposed by Laws and Regulations.
  - e. Deposits lost for causes other than negligence of Contractor, any Subcontractor, or anyone directly or indirectly employed by any of them or for whose acts any of them may be liable, and royalty payments and fees for permits and licenses.
  - f. Losses and damages (and related expenses) caused by damage to the Work, not compensated by insurance or otherwise, sustained by Contractor in connection with the performance of the Work (except losses and damages within the deductible amounts of property insurance established in accordance with Paragraph 6.05), provided such losses and damages have resulted from causes other than the negligence of Contractor, any Subcontractor, or anyone directly or indirectly employed by any of them or for whose acts any of them may be liable. Such losses shall include settlements made with the written consent and approval of Owner. No such losses, damages, and expenses shall be included in the Cost of the Work for the purpose of determining Contractor's fee.
  - g. The cost of utilities, fuel, and sanitary facilities at the Site.



- h. Minor expenses such as communication service at the Site, express and courier services, and similar petty cash items in connection with the Work.
  - i. The costs of premiums for all bonds and insurance that Contractor is required by the Contract Documents to purchase and maintain.
- C. *Costs Excluded*: The term Cost of the Work shall not include any of the following items:
  - 1. Payroll costs and other compensation of Contractor's officers, executives, principals (of partnerships and sole proprietorships), general managers, safety managers, engineers, architects, estimators, attorneys, auditors, accountants, purchasing and contracting agents, expeditors, timekeepers, clerks, and other personnel employed by Contractor, whether at the Site or in Contractor's principal or branch office for general administration of the Work and not specifically included in the agreed upon schedule of job classifications referred to in Paragraph 13.01.B.1 or specifically covered by Paragraph 13.01.B.4. The payroll costs and other compensation excluded here are to be considered administrative costs covered by the Contractor's fee.
  - 2. Expenses of Contractor's principal and branch offices other than Contractor's office at the Site.
  - 3. Any part of Contractor's capital expenses, including interest on Contractor's capital employed for the Work and charges against Contractor for delinquent payments.
  - 4. Costs due to the negligence of Contractor, any Subcontractor, or anyone directly or indirectly employed by any of them or for whose acts any of them may be liable, including but not limited to, the correction of defective Work, disposal of materials or equipment wrongly supplied, and making good any damage to property.
  - 5. Other overhead or general expense costs of any kind and the costs of any item not specifically and expressly included in Paragraph 13.01.B.
- D. *Contractor's Fee*: When the Work as a whole is performed on the basis of cost-plus, Contractor's fee shall be determined as set forth in the Agreement. When the value of any Work covered by a Change Order, Change Proposal, Claim, set-off, or other adjustment in Contract Price is determined on the basis of Cost of the Work, Contractor's fee shall be determined as set forth in Paragraph 11.04.C.
- E. *Documentation*: Whenever the Cost of the Work for any purpose is to be determined pursuant to this Article 13, Contractor will establish and maintain records thereof in accordance with generally accepted accounting practices and submit in a form acceptable to Engineer an itemized cost breakdown together with supporting data.

### 13.02 Allowances

- A. It is understood that Contractor has included in the Contract Price all allowances so named in the Contract Documents and shall cause the Work so covered to be performed for such sums and by such persons or entities as may be acceptable to Owner and Engineer.

- B. *Cash Allowances*: Contractor agrees that:
  - 1. the cash allowances include the cost to Contractor (less any applicable trade discounts) of materials and equipment required by the allowances to be delivered at the Site, and all applicable taxes; and
  - 2. Contractor's costs for unloading and handling on the Site, labor, installation, overhead, profit, and other expenses contemplated for the cash allowances have been included in the Contract Price and not in the allowances, and no demand for additional payment on account of any of the foregoing will be valid.
- C. *Contingency Allowance*: Contractor agrees that a contingency allowance, if any, is for the sole use of Owner to cover unanticipated costs.
- D. Prior to final payment, an appropriate Change Order will be issued as recommended by Engineer to reflect actual amounts due Contractor on account of Work covered by allowances, and the Contract Price shall be correspondingly adjusted.

13.03 *Unit Price Work*

- A. Where the Contract Documents provide that all or part of the Work is to be Unit Price Work, initially the Contract Price will be deemed to include for all Unit Price Work an amount equal to the sum of the unit price for each separately identified item of Unit Price Work times the estimated quantity of each item as indicated in the Agreement.
- B. The estimated quantities of items of Unit Price Work are not guaranteed and are solely for the purpose of comparison of Bids and determining an initial Contract Price. Payments to Contractor for Unit Price Work will be based on actual quantities.
- C. Each unit price will be deemed to include an amount considered by Contractor to be adequate to cover Contractor's overhead and profit for each separately identified item.
- D. Engineer will determine the actual quantities and classifications of Unit Price Work performed by Contractor. Engineer will review with Contractor the Engineer's preliminary determinations on such matters before rendering a written decision thereon (by recommendation of an Application for Payment or otherwise). Engineer's written decision thereon will be final and binding (except as modified by Engineer to reflect changed factual conditions or more accurate data) upon Owner and Contractor, subject to the provisions of the following paragraph.
- E. Within 30 days of Engineer's written decision under the preceding paragraph, Contractor may submit a Change Proposal, or Owner may file a Claim, seeking an adjustment in the Contract Price if:
  - 1. the quantity of any item of Unit Price Work performed by Contractor differs materially and significantly from the estimated quantity of such item indicated in the Agreement;
  - 2. there is no corresponding adjustment with respect to any other item of Work; and

3. Contractor believes that it is entitled to an increase in Contract Price as a result of having incurred additional expense or Owner believes that Owner is entitled to a decrease in Contract Price, and the parties are unable to agree as to the amount of any such increase or decrease.

## **ARTICLE 14 – TESTS AND INSPECTIONS; CORRECTION, REMOVAL OR ACCEPTANCE OF DEFECTIVE WORK**

### *14.01 Access to Work*

- A. Owner, Engineer, their consultants and other representatives and personnel of Owner, independent testing laboratories, and authorities having jurisdiction will have access to the Site and the Work at reasonable times for their observation, inspection, and testing. Contractor shall provide them proper and safe conditions for such access and advise them of Contractor's safety procedures and programs so that they may comply therewith as applicable.

### *14.02 Tests, Inspections, and Approvals*

- A. Contractor shall give Engineer timely notice of readiness of the Work (or specific parts thereof) for all required inspections and tests, and shall cooperate with inspection and testing personnel to facilitate required inspections and tests.
- B. Owner shall retain and pay for the services of an independent inspector, testing laboratory, or other qualified individual or entity to perform all inspections and tests expressly required by the Contract Documents to be furnished and paid for by Owner, except that costs incurred in connection with tests or inspections of covered Work shall be governed by the provisions of Paragraph 14.05.
- C. If Laws or Regulations of any public body having jurisdiction require any Work (or part thereof) specifically to be inspected, tested, or approved by an employee or other representative of such public body, Contractor shall assume full responsibility for arranging and obtaining such inspections, tests, or approvals, pay all costs in connection therewith, and furnish Engineer the required certificates of inspection or approval.
- D. Contractor shall be responsible for arranging, obtaining, and paying for all inspections and tests required:
  1. by the Contract Documents, unless the Contract Documents expressly allocate responsibility for a specific inspection or test to Owner;
  2. to attain Owner's and Engineer's acceptance of materials or equipment to be incorporated in the Work;
  3. by manufacturers of equipment furnished under the Contract Documents;
  4. for testing, adjusting, and balancing of mechanical, electrical, and other equipment to be incorporated into the Work; and
  5. for acceptance of materials, mix designs, or equipment submitted for approval prior to Contractor's purchase thereof for incorporation in the Work.

Such inspections and tests shall be performed by independent inspectors, testing laboratories, or other qualified individuals or entities acceptable to Owner and Engineer.

- E. If the Contract Documents require the Work (or part thereof) to be approved by Owner, Engineer, or another designated individual or entity, then Contractor shall assume full responsibility for arranging and obtaining such approvals.
- F. If any Work (or the work of others) that is to be inspected, tested, or approved is covered by Contractor without written concurrence of Engineer, Contractor shall, if requested by Engineer, uncover such Work for observation. Such uncovering shall be at Contractor's expense unless Contractor had given Engineer timely notice of Contractor's intention to cover the same and Engineer had not acted with reasonable promptness in response to such notice.

#### 14.03 *Defective Work*

- A. *Contractor's Obligation:* It is Contractor's obligation to assure that the Work is not defective.
- B. *Engineer's Authority:* Engineer has the authority to determine whether Work is defective, and to reject defective Work.
- C. *Notice of Defects:* Prompt notice of all defective Work of which Owner or Engineer has actual knowledge will be given to Contractor.
- D. *Correction, or Removal and Replacement:* Promptly after receipt of written notice of defective Work, Contractor shall correct all such defective Work, whether or not fabricated, installed, or completed, or, if Engineer has rejected the defective Work, remove it from the Project and replace it with Work that is not defective.
- E. *Preservation of Warranties:* When correcting defective Work, Contractor shall take no action that would void or otherwise impair Owner's special warranty and guarantee, if any, on said Work.
- F. *Costs and Damages:* In addition to its correction, removal, and replacement obligations with respect to defective Work, Contractor shall pay all claims, costs, losses, and damages arising out of or relating to defective Work, including but not limited to the cost of the inspection, testing, correction, removal, replacement, or reconstruction of such defective Work, fines levied against Owner by governmental authorities because the Work is defective, and the costs of repair or replacement of work of others resulting from defective Work. Prior to final payment, if Owner and Contractor are unable to agree as to the measure of such claims, costs, losses, and damages resulting from defective Work, then Owner may impose a reasonable set-off against payments due under Article 15.

#### 14.04 *Acceptance of Defective Work*

- A. If, instead of requiring correction or removal and replacement of defective Work, Owner prefers to accept it, Owner may do so (subject, if such acceptance occurs prior to final payment, to Engineer's confirmation that such acceptance is in general accord with the design intent and applicable engineering principles, and will not endanger public safety). Contractor shall pay all claims, costs, losses, and damages

attributable to Owner's evaluation of and determination to accept such defective Work (such costs to be approved by Engineer as to reasonableness), and for the diminished value of the Work to the extent not otherwise paid by Contractor. If any such acceptance occurs prior to final payment, the necessary revisions in the Contract Documents with respect to the Work shall be incorporated in a Change Order. If the parties are unable to agree as to the decrease in the Contract Price, reflecting the diminished value of Work so accepted, then Owner may impose a reasonable set-off against payments due under Article 15. If the acceptance of defective Work occurs after final payment, Contractor shall pay an appropriate amount to Owner.

#### 14.05 *Uncovering Work*

- A. Engineer has the authority to require additional inspection or testing of the Work, whether or not the Work is fabricated, installed, or completed.
- B. If any Work is covered contrary to the written request of Engineer, then Contractor shall, if requested by Engineer, uncover such Work for Engineer's observation, and then replace the covering, all at Contractor's expense.
- C. If Engineer considers it necessary or advisable that covered Work be observed by Engineer or inspected or tested by others, then Contractor, at Engineer's request, shall uncover, expose, or otherwise make available for observation, inspection, or testing as Engineer may require, that portion of the Work in question, and provide all necessary labor, material, and equipment.
  - 1. If it is found that the uncovered Work is defective, Contractor shall be responsible for all claims, costs, losses, and damages arising out of or relating to such uncovering, exposure, observation, inspection, and testing, and of satisfactory replacement or reconstruction (including but not limited to all costs of repair or replacement of work of others); and pending Contractor's full discharge of this responsibility the Owner shall be entitled to impose a reasonable set-off against payments due under Article 15.
  - 2. If the uncovered Work is not found to be defective, Contractor shall be allowed an increase in the Contract Price or an extension of the Contract Times, or both, directly attributable to such uncovering, exposure, observation, inspection, testing, replacement, and reconstruction. If the parties are unable to agree as to the amount or extent thereof, then Contractor may submit a Change Proposal within 30 days of the determination that the Work is not defective.

#### 14.06 *Owner May Stop the Work*

- A. If the Work is defective, or Contractor fails to supply sufficient skilled workers or suitable materials or equipment, or fails to perform the Work in such a way that the completed Work will conform to the Contract Documents, then Owner may order Contractor to stop the Work, or any portion thereof, until the cause for such order has been eliminated; however, this right of Owner to stop the Work shall not give rise to any duty on the part of Owner to exercise this right for the benefit of Contractor, any Subcontractor, any Supplier, any other individual or entity, or any surety for, or employee or agent of any of them.

#### 14.07 *Owner May Correct Defective Work*

- A. If Contractor fails within a reasonable time after written notice from Engineer to correct defective Work, or to remove and replace rejected Work as required by Engineer, or if Contractor fails to perform the Work in accordance with the Contract Documents, or if Contractor fails to comply with any other provision of the Contract Documents, then Owner may, after seven days written notice to Contractor, correct or remedy any such deficiency.
- B. In exercising the rights and remedies under this Paragraph 14.07, Owner shall proceed expeditiously. In connection with such corrective or remedial action, Owner may exclude Contractor from all or part of the Site, take possession of all or part of the Work and suspend Contractor's services related thereto, and incorporate in the Work all materials and equipment stored at the Site or for which Owner has paid Contractor but which are stored elsewhere. Contractor shall allow Owner, Owner's representatives, agents and employees, Owner's other contractors, and Engineer and Engineer's consultants access to the Site to enable Owner to exercise the rights and remedies under this paragraph.
- C. All claims, costs, losses, and damages incurred or sustained by Owner in exercising the rights and remedies under this Paragraph 14.07 will be charged against Contractor as set-offs against payments due under Article 15. Such claims, costs, losses and damages will include but not be limited to all costs of repair, or replacement of work of others destroyed or damaged by correction, removal, or replacement of Contractor's defective Work.
- D. Contractor shall not be allowed an extension of the Contract Times because of any delay in the performance of the Work attributable to the exercise by Owner of Owner's rights and remedies under this Paragraph 14.07.

### **ARTICLE 15 – PAYMENTS TO CONTRACTOR; SET-OFFS; COMPLETION; CORRECTION PERIOD**

#### 15.01 *Progress Payments*

- A. *Basis for Progress Payments:* The Schedule of Values established as provided in Article 2 will serve as the basis for progress payments and will be incorporated into a form of Application for Payment acceptable to Engineer. Progress payments on account of Unit Price Work will be based on the number of units completed during the pay period, as determined under the provisions of Paragraph 13.03. Progress payments for cost-based Work will be based on Cost of the Work completed by Contractor during the pay period.
- B. *Applications for Payments:*
  - 1. At least 20 days before the date established in the Agreement for each progress payment (but not more often than once a month), Contractor shall submit to Engineer for review an Application for Payment filled out and signed by Contractor covering the Work completed as of the date of the Application and accompanied by such supporting documentation as is required by the Contract Documents. If payment is requested on the basis of materials and equipment not

incorporated in the Work but delivered and suitably stored at the Site or at another location agreed to in writing, the Application for Payment shall also be accompanied by a bill of sale, invoice, or other documentation warranting that Owner has received the materials and equipment free and clear of all Liens, and evidence that the materials and equipment are covered by appropriate property insurance, a warehouse bond, or other arrangements to protect Owner's interest therein, all of which must be satisfactory to Owner.

2. Beginning with the second Application for Payment, each Application shall include an affidavit of Contractor stating that all previous progress payments received on account of the Work have been applied on account to discharge Contractor's legitimate obligations associated with prior Applications for Payment.
3. The amount of retainage with respect to progress payments will be as stipulated in the Agreement.

C. *Review of Applications:*

1. Engineer will, within 10 days after receipt of each Application for Payment, including each resubmittal, either indicate in writing a recommendation of payment and present the Application to Owner, or return the Application to Contractor indicating in writing Engineer's reasons for refusing to recommend payment. In the latter case, Contractor may make the necessary corrections and resubmit the Application.
2. Engineer's recommendation of any payment requested in an Application for Payment will constitute a representation by Engineer to Owner, based on Engineer's observations of the executed Work as an experienced and qualified design professional, and on Engineer's review of the Application for Payment and the accompanying data and schedules, that to the best of Engineer's knowledge, information and belief:
  - a. the Work has progressed to the point indicated;
  - b. the quality of the Work is generally in accordance with the Contract Documents (subject to an evaluation of the Work as a functioning whole prior to or upon Substantial Completion, the results of any subsequent tests called for in the Contract Documents, a final determination of quantities and classifications for Unit Price Work under Paragraph 13.03, and any other qualifications stated in the recommendation); and
  - c. the conditions precedent to Contractor's being entitled to such payment appear to have been fulfilled in so far as it is Engineer's responsibility to observe the Work.
3. By recommending any such payment Engineer will not thereby be deemed to have represented that:
  - a. inspections made to check the quality or the quantity of the Work as it has been performed have been exhaustive, extended to every aspect of the Work

- in progress, or involved detailed inspections of the Work beyond the responsibilities specifically assigned to Engineer in the Contract; or
- b. there may not be other matters or issues between the parties that might entitle Contractor to be paid additionally by Owner or entitle Owner to withhold payment to Contractor.
4. Neither Engineer's review of Contractor's Work for the purposes of recommending payments nor Engineer's recommendation of any payment, including final payment, will impose responsibility on Engineer:
    - a. to supervise, direct, or control the Work, or
    - b. for the means, methods, techniques, sequences, or procedures of construction, or the safety precautions and programs incident thereto, or
    - c. for Contractor's failure to comply with Laws and Regulations applicable to Contractor's performance of the Work, or
    - d. to make any examination to ascertain how or for what purposes Contractor has used the money paid on account of the Contract Price, or
    - e. to determine that title to any of the Work, materials, or equipment has passed to Owner free and clear of any Liens.
  5. Engineer may refuse to recommend the whole or any part of any payment if, in Engineer's opinion, it would be incorrect to make the representations to Owner stated in Paragraph 15.01.C.2.
  6. Engineer will recommend reductions in payment (set-offs) necessary in Engineer's opinion to protect Owner from loss because:
    - a. the Work is defective, requiring correction or replacement;
    - b. the Contract Price has been reduced by Change Orders;
    - c. Owner has been required to correct defective Work in accordance with Paragraph 14.07, or has accepted defective Work pursuant to Paragraph 14.04;
    - d. Owner has been required to remove or remediate a Hazardous Environmental Condition for which Contractor is responsible; or
    - e. Engineer has actual knowledge of the occurrence of any of the events that would constitute a default by Contractor and therefore justify termination for cause under the Contract Documents.

*D. Payment Becomes Due:*

1. Ten days after presentation of the Application for Payment to Owner with Engineer's recommendation, the amount recommended (subject to any Owner set-offs) will become due, and when due will be paid by Owner to Contractor.



E. *Reductions in Payment by Owner:*

1. In addition to any reductions in payment (set-offs) recommended by Engineer, Owner is entitled to impose a set-off against payment based on any of the following:
  - a. claims have been made against Owner on account of Contractor's conduct in the performance or furnishing of the Work, or Owner has incurred costs, losses, or damages on account of Contractor's conduct in the performance or furnishing of the Work, including but not limited to claims, costs, losses, or damages from workplace injuries, adjacent property damage, non-compliance with Laws and Regulations, and patent infringement;
  - b. Contractor has failed to take reasonable and customary measures to avoid damage, delay, disruption, and interference with other work at or adjacent to the Site;
  - c. Contractor has failed to provide and maintain required bonds or insurance;
  - d. Owner has been required to remove or remediate a Hazardous Environmental Condition for which Contractor is responsible;
  - e. Owner has incurred extra charges or engineering costs related to submittal reviews, evaluations of proposed substitutes, tests and inspections, or return visits to manufacturing or assembly facilities;
  - f. the Work is defective, requiring correction or replacement;
  - g. Owner has been required to correct defective Work in accordance with Paragraph 14.07, or has accepted defective Work pursuant to Paragraph 14.04;
  - h. the Contract Price has been reduced by Change Orders;
  - i. an event that would constitute a default by Contractor and therefore justify a termination for cause has occurred;
  - j. liquidated damages have accrued as a result of Contractor's failure to achieve Milestones, Substantial Completion, or final completion of the Work;
  - k. Liens have been filed in connection with the Work, except where Contractor has delivered a specific bond satisfactory to Owner to secure the satisfaction and discharge of such Liens;
  - l. there are other items entitling Owner to a set off against the amount recommended.
2. If Owner imposes any set-off against payment, whether based on its own knowledge or on the written recommendations of Engineer, Owner will give Contractor immediate written notice (with a copy to Engineer) stating the reasons for such action and the specific amount of the reduction, and promptly pay Contractor any amount remaining after deduction of the amount so withheld. Owner shall promptly pay Contractor the amount so withheld, or any

adjustment thereto agreed to by Owner and Contractor, if Contractor remedies the reasons for such action. The reduction imposed shall be binding on Contractor unless it duly submits a Change Proposal contesting the reduction.

3. Upon a subsequent determination that Owner's refusal of payment was not justified, the amount wrongfully withheld shall be treated as an amount due as determined by Paragraph 15.01.C.1 and subject to interest as provided in the Agreement.

#### 15.02 *Contractor's Warranty of Title*

- A. Contractor warrants and guarantees that title to all Work, materials, and equipment furnished under the Contract will pass to Owner free and clear of (1) all Liens and other title defects, and (2) all patent, licensing, copyright, or royalty obligations, no later than seven days after the time of payment by Owner.

#### 15.03 *Substantial Completion*

- A. When Contractor considers the entire Work ready for its intended use Contractor shall notify Owner and Engineer in writing that the entire Work is substantially complete and request that Engineer issue a certificate of Substantial Completion. Contractor shall at the same time submit to Owner and Engineer an initial draft of punch list items to be completed or corrected before final payment.
- B. Promptly after Contractor's notification, Owner, Contractor, and Engineer shall make an inspection of the Work to determine the status of completion. If Engineer does not consider the Work substantially complete, Engineer will notify Contractor in writing giving the reasons therefor.
- C. If Engineer considers the Work substantially complete, Engineer will deliver to Owner a preliminary certificate of Substantial Completion which shall fix the date of Substantial Completion. Engineer shall attach to the certificate a punch list of items to be completed or corrected before final payment. Owner shall have seven days after receipt of the preliminary certificate during which to make written objection to Engineer as to any provisions of the certificate or attached punch list. If, after considering the objections to the provisions of the preliminary certificate, Engineer concludes that the Work is not substantially complete, Engineer will, within 14 days after submission of the preliminary certificate to Owner, notify Contractor in writing that the Work is not substantially complete, stating the reasons therefor. If Owner does not object to the provisions of the certificate, or if despite consideration of Owner's objections Engineer concludes that the Work is substantially complete, then Engineer will, within said 14 days, execute and deliver to Owner and Contractor a final certificate of Substantial Completion (with a revised punch list of items to be completed or corrected) reflecting such changes from the preliminary certificate as Engineer believes justified after consideration of any objections from Owner.
- D. At the time of receipt of the preliminary certificate of Substantial Completion, Owner and Contractor will confer regarding Owner's use or occupancy of the Work following Substantial Completion, review the builder's risk insurance policy with respect to the end of the builder's risk coverage, and confirm the transition to coverage of the Work under a permanent property insurance policy held by Owner.

Unless Owner and Contractor agree otherwise in writing, Owner shall bear responsibility for security, operation, protection of the Work, property insurance, maintenance, heat, and utilities upon Owner's use or occupancy of the Work.

- E. After Substantial Completion the Contractor shall promptly begin work on the punch list of items to be completed or corrected prior to final payment. In appropriate cases Contractor may submit monthly Applications for Payment for completed punch list items, following the progress payment procedures set forth above.
- F. Owner shall have the right to exclude Contractor from the Site after the date of Substantial Completion subject to allowing Contractor reasonable access to remove its property and complete or correct items on the punch list.

#### 15.04 *Partial Use or Occupancy*

- A. Prior to Substantial Completion of all the Work, Owner may use or occupy any substantially completed part of the Work which has specifically been identified in the Contract Documents, or which Owner, Engineer, and Contractor agree constitutes a separately functioning and usable part of the Work that can be used by Owner for its intended purpose without significant interference with Contractor's performance of the remainder of the Work, subject to the following conditions:
  - 1. At any time Owner may request in writing that Contractor permit Owner to use or occupy any such part of the Work that Owner believes to be substantially complete. If and when Contractor agrees that such part of the Work is substantially complete, Contractor, Owner, and Engineer will follow the procedures of Paragraph 15.03.A through E for that part of the Work.
  - 2. At any time Contractor may notify Owner and Engineer in writing that Contractor considers any such part of the Work substantially complete and request Engineer to issue a certificate of Substantial Completion for that part of the Work.
  - 3. Within a reasonable time after either such request, Owner, Contractor, and Engineer shall make an inspection of that part of the Work to determine its status of completion. If Engineer does not consider that part of the Work to be substantially complete, Engineer will notify Owner and Contractor in writing giving the reasons therefor. If Engineer considers that part of the Work to be substantially complete, the provisions of Paragraph 15.03 will apply with respect to certification of Substantial Completion of that part of the Work and the division of responsibility in respect thereof and access thereto.
  - 4. No use or occupancy or separate operation of part of the Work may occur prior to compliance with the requirements of Paragraph 6.05 regarding builder's risk or other property insurance.

#### 15.05 *Final Inspection*

- A. Upon written notice from Contractor that the entire Work or an agreed portion thereof is complete, Engineer will promptly make a final inspection with Owner and Contractor and will notify Contractor in writing of all particulars in which this inspection reveals that the Work, or agreed portion thereof, is incomplete or

defective. Contractor shall immediately take such measures as are necessary to complete such Work or remedy such deficiencies.

#### 15.06 *Final Payment*

##### A. *Application for Payment:*

1. After Contractor has, in the opinion of Engineer, satisfactorily completed all corrections identified during the final inspection and has delivered, in accordance with the Contract Documents, all maintenance and operating instructions, schedules, guarantees, bonds, certificates or other evidence of insurance, certificates of inspection, annotated record documents (as provided in Paragraph 7.11), and other documents, Contractor may make application for final payment.
2. The final Application for Payment shall be accompanied (except as previously delivered) by:
  - a. all documentation called for in the Contract Documents;
  - b. consent of the surety, if any, to final payment;
  - c. satisfactory evidence that all title issues have been resolved such that title to all Work, materials, and equipment has passed to Owner free and clear of any Liens or other title defects, or will so pass upon final payment.
  - d. a list of all disputes that Contractor believes are unsettled; and
  - e. complete and legally effective releases or waivers (satisfactory to Owner) of all Lien rights arising out of the Work, and of Liens filed in connection with the Work.
3. In lieu of the releases or waivers of Liens specified in Paragraph 15.06.A.2 and as approved by Owner, Contractor may furnish receipts or releases in full and an affidavit of Contractor that: (a) the releases and receipts include all labor, services, material, and equipment for which a Lien could be filed; and (b) all payrolls, material and equipment bills, and other indebtedness connected with the Work for which Owner might in any way be responsible, or which might in any way result in liens or other burdens on Owner's property, have been paid or otherwise satisfied. If any Subcontractor or Supplier fails to furnish such a release or receipt in full, Contractor may furnish a bond or other collateral satisfactory to Owner to indemnify Owner against any Lien, or Owner at its option may issue joint checks payable to Contractor and specified Subcontractors and Suppliers.

##### B. *Engineer's Review of Application and Acceptance:*

1. If, on the basis of Engineer's observation of the Work during construction and final inspection, and Engineer's review of the final Application for Payment and accompanying documentation as required by the Contract Documents, Engineer is satisfied that the Work has been completed and Contractor's other obligations under the Contract have been fulfilled, Engineer will, within ten days after receipt of the final Application for Payment, indicate in writing Engineer's

recommendation of final payment and present the Application for Payment to Owner for payment. Such recommendation shall account for any set-offs against payment that are necessary in Engineer's opinion to protect Owner from loss for the reasons stated above with respect to progress payments. At the same time Engineer will also give written notice to Owner and Contractor that the Work is acceptable, subject to the provisions of Paragraph 15.07. Otherwise, Engineer will return the Application for Payment to Contractor, indicating in writing the reasons for refusing to recommend final payment, in which case Contractor shall make the necessary corrections and resubmit the Application for Payment.

- C. *Completion of Work*: The Work is complete (subject to surviving obligations) when it is ready for final payment as established by the Engineer's written recommendation of final payment.
- D. *Payment Becomes Due*: Thirty days after the presentation to Owner of the final Application for Payment and accompanying documentation, the amount recommended by Engineer (less any further sum Owner is entitled to set off against Engineer's recommendation, including but not limited to set-offs for liquidated damages and set-offs allowed under the provisions above with respect to progress payments) will become due and shall be paid by Owner to Contractor.

#### 15.07 *Waiver of Claims*

- A. The making of final payment will not constitute a waiver by Owner of claims or rights against Contractor. Owner expressly reserves claims and rights arising from unsettled Liens, from defective Work appearing after final inspection pursuant to Paragraph 15.05, from Contractor's failure to comply with the Contract Documents or the terms of any special guarantees specified therein, from outstanding Claims by Owner, or from Contractor's continuing obligations under the Contract Documents.
- B. The acceptance of final payment by Contractor will constitute a waiver by Contractor of all claims and rights against Owner other than those pending matters that have been duly submitted or appealed under the provisions of Article 17.

#### 15.08 *Correction Period*

- A. If within one year after the date of Substantial Completion (or such longer period of time as may be prescribed by the terms of any applicable special guarantee required by the Contract Documents, or by any specific provision of the Contract Documents), any Work is found to be defective, or if the repair of any damages to the Site, adjacent areas that Contractor has arranged to use through construction easements or otherwise, and other adjacent areas used by Contractor as permitted by Laws and Regulations, is found to be defective, then Contractor shall promptly, without cost to Owner and in accordance with Owner's written instructions:
  - 1. correct the defective repairs to the Site or such other adjacent areas;
  - 2. correct such defective Work;
  - 3. if the defective Work has been rejected by Owner, remove it from the Project and replace it with Work that is not defective, and

4. satisfactorily correct or repair or remove and replace any damage to other Work, to the work of others, or to other land or areas resulting therefrom.
- B. If Contractor does not promptly comply with the terms of Owner's written instructions, or in an emergency where delay would cause serious risk of loss or damage, Owner may have the defective Work corrected or repaired or may have the rejected Work removed and replaced. Contractor shall pay all claims, costs, losses, and damages (including but not limited to all fees and charges of engineers, architects, attorneys, and other professionals and all court or arbitration or other dispute resolution costs) arising out of or relating to such correction or repair or such removal and replacement (including but not limited to all costs of repair or replacement of work of others).
- C. In special circumstances where a particular item of equipment is placed in continuous service before Substantial Completion of all the Work, the correction period for that item may start to run from an earlier date if so provided in the Specifications.
- D. Where defective Work (and damage to other Work resulting therefrom) has been corrected or removed and replaced under this paragraph, the correction period hereunder with respect to such Work will be extended for an additional period of one year after such correction or removal and replacement has been satisfactorily completed.
- E. Contractor's obligations under this paragraph are in addition to all other obligations and warranties. The provisions of this paragraph shall not be construed as a substitute for, or a waiver of, the provisions of any applicable statute of limitation or repose.

## **ARTICLE 16 – SUSPENSION OF WORK AND TERMINATION**

### *16.01 Owner May Suspend Work*

- A. At any time and without cause, Owner may suspend the Work or any portion thereof for a period of not more than 90 consecutive days by written notice to Contractor and Engineer. Such notice will fix the date on which Work will be resumed. Contractor shall resume the Work on the date so fixed. Contractor shall be entitled to an adjustment in the Contract Price or an extension of the Contract Times, or both, directly attributable to any such suspension. Any Change Proposal seeking such adjustments shall be submitted no later than 30 days after the date fixed for resumption of Work.

### *16.02 Owner May Terminate for Cause*

- A. The occurrence of any one or more of the following events will constitute a default by Contractor and justify termination for cause:
  1. Contractor's persistent failure to perform the Work in accordance with the Contract Documents (including, but not limited to, failure to supply sufficient

- skilled workers or suitable materials or equipment or failure to adhere to the Progress Schedule);
2. Failure of Contractor to perform or otherwise to comply with a material term of the Contract Documents;
  3. Contractor's disregard of Laws or Regulations of any public body having jurisdiction; or
  4. Contractor's repeated disregard of the authority of Owner or Engineer.
- B. If one or more of the events identified in Paragraph 16.02.A occurs, then after giving Contractor (and any surety) ten days written notice that Owner is considering a declaration that Contractor is in default and termination of the contract, Owner may proceed to:
1. declare Contractor to be in default, and give Contractor (and any surety) notice that the Contract is terminated; and
  2. enforce the rights available to Owner under any applicable performance bond.
- C. Subject to the terms and operation of any applicable performance bond, if Owner has terminated the Contract for cause, Owner may exclude Contractor from the Site, take possession of the Work, incorporate in the Work all materials and equipment stored at the Site or for which Owner has paid Contractor but which are stored elsewhere, and complete the Work as Owner may deem expedient.
- D. Owner may not proceed with termination of the Contract under Paragraph 16.02.B if Contractor within seven days of receipt of notice of intent to terminate begins to correct its failure to perform and proceeds diligently to cure such failure.
- E. If Owner proceeds as provided in Paragraph 16.02.B, Contractor shall not be entitled to receive any further payment until the Work is completed. If the unpaid balance of the Contract Price exceeds the cost to complete the Work, including all related claims, costs, losses, and damages (including but not limited to all fees and charges of engineers, architects, attorneys, and other professionals) sustained by Owner, such excess will be paid to Contractor. If the cost to complete the Work including such related claims, costs, losses, and damages exceeds such unpaid balance, Contractor shall pay the difference to Owner. Such claims, costs, losses, and damages incurred by Owner will be reviewed by Engineer as to their reasonableness and, when so approved by Engineer, incorporated in a Change Order. When exercising any rights or remedies under this paragraph, Owner shall not be required to obtain the lowest price for the Work performed.
- F. Where Contractor's services have been so terminated by Owner, the termination will not affect any rights or remedies of Owner against Contractor then existing or which may thereafter accrue, or any rights or remedies of Owner against Contractor or any surety under any payment bond or performance bond. Any retention or payment of money due Contractor by Owner will not release Contractor from liability.
- G. If and to the extent that Contractor has provided a performance bond under the provisions of Paragraph 6.01.A, the provisions of that bond shall govern over any inconsistent provisions of Paragraphs 16.02.B and 16.02.D.

16.03 *Owner May Terminate For Convenience*

- A. Upon seven days written notice to Contractor and Engineer, Owner may, without cause and without prejudice to any other right or remedy of Owner, terminate the Contract. In such case, Contractor shall be paid for (without duplication of any items):
  - 1. completed and acceptable Work executed in accordance with the Contract Documents prior to the effective date of termination, including fair and reasonable sums for overhead and profit on such Work;
  - 2. expenses sustained prior to the effective date of termination in performing services and furnishing labor, materials, or equipment as required by the Contract Documents in connection with uncompleted Work, plus fair and reasonable sums for overhead and profit on such expenses; and
  - 3. other reasonable expenses directly attributable to termination, including costs incurred to prepare a termination for convenience cost proposal.
- B. Contractor shall not be paid on account of loss of anticipated overhead, profits, or revenue, or other economic loss arising out of or resulting from such termination.

16.04 *Contractor May Stop Work or Terminate*

- A. If, through no act or fault of Contractor, (1) the Work is suspended for more than 90 consecutive days by Owner or under an order of court or other public authority, or (2) Engineer fails to act on any Application for Payment within 30 days after it is submitted, or (3) Owner fails for 30 days to pay Contractor any sum finally determined to be due, then Contractor may, upon seven days written notice to Owner and Engineer, and provided Owner or Engineer do not remedy such suspension or failure within that time, terminate the contract and recover from Owner payment on the same terms as provided in Paragraph 16.03.
- B. In lieu of terminating the Contract and without prejudice to any other right or remedy, if Engineer has failed to act on an Application for Payment within 30 days after it is submitted, or Owner has failed for 30 days to pay Contractor any sum finally determined to be due, Contractor may, seven days after written notice to Owner and Engineer, stop the Work until payment is made of all such amounts due Contractor, including interest thereon. The provisions of this paragraph are not intended to preclude Contractor from submitting a Change Proposal for an adjustment in Contract Price or Contract Times or otherwise for expenses or damage directly attributable to Contractor's stopping the Work as permitted by this paragraph.



## **ARTICLE 17 – FINAL RESOLUTION OF DISPUTES**

### *17.01 Methods and Procedures*

- A. *Disputes Subject to Final Resolution:* The following disputed matters are subject to final resolution under the provisions of this Article:
  - 1. A timely appeal of an approval in part and denial in part of a Claim, or of a denial in full; and
  - 2. Disputes between Owner and Contractor concerning the Work or obligations under the Contract Documents, and arising after final payment has been made.
- B. *Final Resolution of Disputes:* For any dispute subject to resolution under this Article, Owner or Contractor may:
  - 1. elect in writing to invoke the dispute resolution process provided for in the Supplementary Conditions; or
  - 2. agree with the other party to submit the dispute to another dispute resolution process; or
  - 3. if no dispute resolution process is provided for in the Supplementary Conditions or mutually agreed to, give written notice to the other party of the intent to submit the dispute to a court of competent jurisdiction.

## **ARTICLE 18 – MISCELLANEOUS**

### *18.01 Giving Notice*

- A. Whenever any provision of the Contract Documents requires the giving of written notice, it will be deemed to have been validly given if:
  - 1. delivered in person, by a commercial courier service or otherwise, to the individual or to a member of the firm or to an officer of the corporation for which it is intended; or
  - 2. delivered at or sent by registered or certified mail, postage prepaid, to the last business address known to the sender of the notice.

### *18.02 Computation of Times*

- A. When any period of time is referred to in the Contract by days, it will be computed to exclude the first and include the last day of such period. If the last day of any such period falls on a Saturday or Sunday or on a day made a legal holiday by the law of the applicable jurisdiction, such day will be omitted from the computation.

### *18.03 Cumulative Remedies*

- A. The duties and obligations imposed by these General Conditions and the rights and remedies available hereunder to the parties hereto are in addition to, and are not to be construed in any way as a limitation of, any rights and remedies available to any or all of them which are otherwise imposed or available by Laws or Regulations, by special warranty or guarantee, or by other provisions of the Contract. The provisions of this paragraph will be as effective as if repeated specifically in the Contract

Documents in connection with each particular duty, obligation, right, and remedy to which they apply.

18.04 *Limitation of Damages*

- A. With respect to any and all Change Proposals, Claims, disputes subject to final resolution, and other matters at issue, neither Owner nor Engineer, nor any of their officers, directors, members, partners, employees, agents, consultants, or subcontractors, shall be liable to Contractor for any claims, costs, losses, or damages sustained by Contractor on or in connection with any other project or anticipated project.

18.05 *No Waiver*

- A. A party's non-enforcement of any provision shall not constitute a waiver of that provision, nor shall it affect the enforceability of that provision or of the remainder of this Contract.

18.06 *Survival of Obligations*

- A. All representations, indemnifications, warranties, and guarantees made in, required by, or given in accordance with the Contract, as well as all continuing obligations indicated in the Contract, will survive final payment, completion, and acceptance of the Work or termination or completion of the Contract or termination of the services of Contractor.

18.07 *Controlling Law*

- A. This Contract is to be governed by the law of the state in which the Project is located.

18.08 *Headings*

- A. Article and paragraph headings are inserted for convenience only and do not constitute parts of these General Conditions.

SECTION 00800

SUPPLEMENTAL GENERAL CONDITIONS

**ARTICLE 1. DEFINITIONS AND TERMINOLOGY**

**SC-1.01.A.13**

Add the following language at the beginning of the definition entitled "Contract Documents" in the General Conditions:

The Invitation to Bid, Instructions to Bidders

**SC-1.01.A.28**

Add the following language to the definition entitled "Owner" in the General Conditions:

The "Owner" shall mean the Town of Dedham, Massachusetts.

**SC-1.01.A.40**

Delete the definition of Substantial Completion in the General Conditions in its entirety and add the following in its place:

1. The Work required by the Contract has been completed except for work having a Contract Price of less than one percent of the then adjusted total contract price, or substantially all of the Work has been completed and opened to Owner's use except for minor incomplete or unsatisfactory work items that do not materially impair the usefulness of the Work required by the Contract.

**SC-1.01.A.49**

Add the following definition to the General Conditions:

"State" shall mean the Commonwealth of Massachusetts.

**ARTICLE 2. PRELIMINARY MATTERS**

**SC-2.01.C**

Delete this paragraph

**SC-2.01.D**

Add a new paragraph immediately after paragraph 2.01.C of the General Conditions, which is to read as follows:

- D. **Non-Resident Contractor:** The CONTRACTOR, if a corporation established under laws other than the State in which the proposed construction is located, shall file with the OWNER, notice of the name of its resident attorney-in-fact, appointed as required by the laws of the State in which the proposed construction is located. The CONTRACTOR, if a resident of a State other than that in which the proposed construction is located and not a corporation, shall file, at the time of execution of the Agreement, with the OWNER a written appointment of a resident of the State in which the construction is located, having an office or place of business therein, to be his true and lawful attorney upon whom all lawful processes in any actions or proceedings against him may be served; and in such writing, which shall set forth said attorney's place of residence, shall agree that any lawful process against him which is served on said attorney shall be of the same legal force and validity as if served on him and that the authority shall continue in force so long as any liability remains outstanding against him in said State. The power of attorney shall be filed in the office of the Secretary of the State if required, and copies certified by the Secretary shall be sufficient evidence thereof. Such appointment shall continue in force until revoked by an instrument in writing, designating in a like manner some other person upon whom such processes may be served, which instrument shall be filed in the manner provided herein for the original appointment.

#### **SC-2.05**

Add the following paragraphs immediately after paragraph 2.05.A.3 of the General Conditions which is to read as follows:

2.05.A.4 Before any work at the site is started, CONTRACTOR shall deliver to OWNER, with a copy to ENGINEER, certificates of insurance (and other evidence of insurance requested by OWNER) which CONTRACTOR is required to purchase and maintain in accordance with the requirements of Article 6.

2.05.A.5 Contractor shall include and identify on the certificate of insurance, indemnification as required by Article 7.18.

### **ARTICLE 3. DOCUMENTS: INTENT, REQUIREMENTS, REUSE**

#### **SC-3.01**

Add the following paragraphs immediately after paragraph 3.01.A of the General Conditions which is to read as follows:

3.01.A.1 Each and every provision of law and clause required by law to be inserted in the Contract shall be deemed to be inserted herein, and the Contract shall be read and enforced as though they were included herein. If through mistake or otherwise any such provision is not inserted, or is not correctly inserted, then upon the application of either party, the Contract shall forthwith be physically amended to make such insertion.

3.01.A.2 Sections of Division 1 - General Requirements govern the execution of the work of all sections of the specifications.

### **SC-3.02.A.1**

Delete the portion of the paragraph starting at “shall mean” through the end of this sentence and insert the following:

“shall mean the standard, specification, manual, code, or Laws or Regulations in effect and applicable at the time in question, except as may be otherwise specifically stated in the Contract Documents.”

### **SC-3.03.A.3**

Delete Paragraph 3.03.A.3 in its entirety and insert the following:

“CONTRACTOR shall be liable to OWNER and/or ENGINEER for failure to report any such conflict, error, ambiguity or discrepancy if Contractor knew or reasonably should have known thereof.”

## **ARTICLE 4. COMMENCEMENT AND PROGRESS OF THE WORK**

### **SC 4.01**

Delete paragraph 4.01 in its entirety and insert the following in its place:

4.01 The Contract Time will commence to run on the day indicated in the Notice to Proceed.

### **SC-4.03.A**

Add a new paragraph at the end of paragraph 4.03.A of the General Conditions which is to read as follows:

“4.03.B ENGINEER may check the lines, elevations, reference marks, batter boards, etc., set by CONTRACTOR, and CONTRACTOR shall correct any errors disclosed by such check. Such a check shall not be considered as approval of CONTRACTOR's work and shall not relieve CONTRACTOR of the responsibility for accurate and satisfactory construction and completion of the entire Work. CONTRACTOR shall furnish personnel to assist ENGINEER in checking lines and grades.”

### **SC-4.04**

Add the following paragraph after paragraph 4.04.A.2 of the General Conditions:

"3. The CONTRACTOR's resident superintendent shall attend monthly progress meetings at the site of the work with the ENGINEER and others as appropriate to review schedule status and such other pertinent subjects as may be listed on the agenda by the ENGINEER."

#### **SC- 4.05.A**

Delete Paragraph 4.05.A in its entirety.

#### **SC-4.05.G**

Delete Paragraph 4.05.G and insert the following in its place:

“Delays caused by or within the control of the OWNER: In such event, the CONTRACTOR’S sole remedy shall be an extension of the Contract Time. Notwithstanding anything to the contrary in the Contract Documents, CONTRACTOR shall not be eligible for any increase in the Contract Price on account of any delay in the Work, no matter by whom such delay is caused, and CONTRACTOR shall make no claim for such an increase, whether such claim is styled as a claim for delay damages, acceleration of work, loss of production, or otherwise.”

### **ARTICLE 5. AVAILABILITY OF LANDS; SUBSURFACE AND PHYSICAL CONDITIONS; HAZARDOUS ENVIRONMENTAL CONDITIONS**

#### **SC-5.01**

Add a new paragraph immediately after paragraph 5.01.A of the General Conditions which is to read as follows:

“5.01.A.1 If all lands and rights-of-way are not obtained as herein contemplated before construction begins, CONTRACTOR shall begin the Work upon such land and rights-of-way as OWNER has previously acquired and no claim for damages whatsoever will be allowed by reason of the delay in obtaining the remaining lands and rights-of-way. Should OWNER be prevented or enjoined from proceeding with the Work, or from authorizing its prosecution, either before or after the commencement, by reason of any litigation, or by reason of its inability to procure any lands or rights-of-way for the Work, CONTRACTOR shall not be entitled to make or assert claim for damage by reason of said delay, or to withdraw from the Agreement except by consent of OWNER. Time for completion of the Work will be extended as provided in Article 11, to such time as OWNER determines will compensate for the time lost by such delay.”

#### **SC-5.01.B**

Delete Paragraph 5.01.B in its entirety.

#### **SC-5.03**

In paragraph 5.03.B insert the word “reasonably” before the word “rely” in the first line and insert the following at the end of the first sentence:

“; the OWNER does not warrant or guarantee the accuracy or completeness of the information therein, and the CONTRACTOR may not so rely to the extent that the

CONTRACTOR knows, or reasonably should have known, of any inaccuracy or omission therein.

#### **SC-5.04**

Insert the following paragraph before Paragraph 5.04.A

##### **“5.04 Differing Subsurface or Physical Conditions**

In accordance with Massachusetts General Laws Chapter 30, Section 39N, if, during the progress of the Work, the CONTRACTOR or the OWNER discovers that the actual subsurface or latent physical conditions encountered at the site differ substantially or materially from those shown on the plans or indicated in the Contract Documents either the CONTRACTOR or the OWNER may request an equitable adjustment in the Contract Price applying to work affected by the differing site conditions. A request for such an adjustment shall be in writing and shall be delivered by the party making such request to the other party as soon as possible after such conditions are discovered. Upon receipt of such a request from the CONTRACTOR, or upon its own initiative, the OWNER will make an investigation of such physical conditions, and if they differ substantially or materially from those shown on the plans or indicated in the Contract Documents or from those ordinarily encountered and generally recognized as inherent in work of the character provided for in the plans and Contract Documents and are of such a nature as to cause an increase or decrease in the cost of performance of the Work or a change in the construction methods required for the performance of the Work which results in an increase or decrease in the cost of the Work, the OWNER will make an equitable adjustment in the Contract Price and the Contract shall be modified in writing accordingly.”

#### **SC-5.04.D.1**

Delete Paragraph 5.04.D.1 in its entirety.

Add a new paragraph immediately after paragraph 5.04.D of the General Conditions which is to read as follows:

“5.04.E Adjustments resulting from actual subsurface or latent physical conditions from those indicated will be in accordance with Massachusetts General Law, Chapter 30, Section 39N and the applicable provisions of the Contract Documents.”

#### **SC-5.05.A**

Insert the following new paragraph immediately after Paragraph 5.05.A.2:

“3. CONTRACTOR’s attention is directed to the requirements of Massachusetts General Laws Chapter 82, Section 40, regarding the notification of owners of underground facilities.”

#### **SC-5.05.B**

Delete the phrase “or was not shown or indicated with reasonable accuracy” following the words “Contract Documents” in the first sentence of Paragraph 5.05.B.

**SC-5.06.B**

Delete Paragraph 5.06.B in its entirety.

**SC-5.06.C**

Add the following at the end of Paragraph 5.06.C:

“,or unless CONTRACTOR caused or contributed to such Hazardous Environmental Condition.”

**SC-5.06.E**

Delete the second and third sentences of Paragraph 5.06.E.

**SC-5.06.I**

Delete Paragraph 5.06.I in its entirety.

**SC-5.06.J**

Delete the last sentence of Paragraph 5.06.J.

**ARTICLE 6.                      BONDS AND INSURANCE**

**SC-6.02**

Delete Paragraph 6.02.D in its entirety.

Add a new paragraph immediately after paragraph 6.02.J of the General Conditions which is to read as follows:

"K.     If OWNER has any objection to the coverage afforded by or other provisions of the insurance required to be purchased and maintained by CONTRACTOR in accordance with this Article 6 on the basis of its not complying with the Contract Documents, OWNER will notify CONTRACTOR in writing thereof within thirty days of the date of delivery of such certificates to OWNER in accordance with paragraph 2.01.B CONTRACTOR will provide such additional information in respect of insurance provided by him as OWNER may reasonably request."

**SC-6.03**

The limits of liability for the insurance required by paragraph 6.03 of the General Conditions shall provide the following coverages for not less than the following amounts or greater where required by Laws and Regulations:

6.03.A Workers' Compensation.



- |     |                       |                                      |
|-----|-----------------------|--------------------------------------|
| (1) | Worker's Compensation | As required by Massachusetts statute |
| (2) | Employer's Liability  | \$1,000,000                          |

The Workers' Compensation policy shall contain a Waiver of Subrogation in favor of the Owner.

6.03.B and 6.03.C Comprehensive General Liability including Operations/Premises, Contractor's Protective, Products/Completed Operations, and Personal Injury liabilities:

- |     |  |             |                  |
|-----|--|-------------|------------------|
| (1) | Bodily injury:   | \$1,000,000 | Each occurrence  |
|     |  | \$2,000,000 | Annual aggregate |
| (2) | Property damage, including explosion, collapse and underground coverage:   | \$1,000,000 | Each occurrence  |
|     |  | \$2,000,000 | Annual aggregate |
|     | Property damage liability insurance shall provide coverage for property in the care, custody and control of the insured. |             |                  |
| (3) | Personal injury, with employment exclusion deleted:  | \$2,000,000 | Annual aggregate |

The Contractual Liability required by paragraph 6.03.C of the General Conditions shall provide coverage for not less than the following amounts:

- |     |  |             |                  |
|-----|--|-------------|------------------|
| (1) | Bodily injury:   | \$1,000,000 | Each occurrence  |
|     |  | \$2,000,000 | Annual aggregate |
| (2) | Property damage, including explosion, collapse and underground coverage: | \$1,000,000 | Each occurrence  |
|     |  | \$2,000,000 | Annual aggregate |
| (3) | General Aggregate  | \$2,000,000 |                  |

Completed Operations coverage shall be maintained for a period of three years after Substantial Completion and acceptance by Owner. The policy shall include the Owner and affiliates as Additional Insureds via endorsements CG 20 10 10 01 and CG 20 37 10 01 or equivalent, and such insurance shall be Primary and Non-Contributory with respect to any other insurance available to Additional Insureds.

A Waiver of Subrogation shall be provided in favor of the Owner via endorsement CG 24 04 05 09 or equivalent.

6.03.D Comprehensive Automobile Liability including owned, hired and non-owned vehicles:

- |     |                |             |             |
|-----|----------------|-------------|-------------|
| (1) | Bodily injury: | \$1,000,000 | Each person |
|-----|----------------|-------------|-------------|

		\$1,000,000	Each accident
(2)	Property damage	\$1,000,000	Each occurrence

The Commercial Automobile policy shall contain a Waiver of Subrogation in favor of the Owner. The policy shall include the Owner and affiliates as Additional Insured, and such insurance shall be primary and non-contributory with respect to any other insurance available to the Additional Insured.

6.03.E Umbrella or Excess Liability

The Contractor shall provide Umbrella Liability coverage with the following limits in a form at least as broad as primary coverages required by Sections 6.3.A, B, C & D:

\$5,000,000 Each Occurrence  
 \$5,000,000 Annual Aggregate

To the extent provided on underlying forms, Additional Insured status shall be provided to Owner and affiliates on a Primary/Non-Contributory basis. A Waiver of Subrogation shall be provided in favor of Owner.

6.03.F Pollution Liability

The Pollution Liability policy shall contain a Waiver of Subrogation in favor of the Owner and affiliates. The policy shall include the Owner and affiliates as Additional Insured, and such insurance shall be primary and non-contributory with respect to any other insurance available to Additional Insureds. Limits required shall be as follows:

\$1,000,000 Each Claim  
 \$1,000,000 Annual Aggregate

**SC-6.04**

Delete paragraph 6.04 of the General Conditions in its entirety and insert the following in its place:

6.04.A CONTRACTOR shall purchase and maintain a separate Owner's Protective Liability policy, issued to OWNER at the expense of CONTRACTOR, including OWNER and ENGINEER as named insured. This insurance shall provide coverage for not less than the following amounts:

6.04.A.1	Bodily Injury:	
	Each Occurrence	\$1,000,000

6.04.A.2	Property Damage:	
	Each Occurrence	\$1,000,000
	Annual Aggregate	\$1,000,000

**SC-6.05**

Delete Paragraph 6.05.A of the General Conditions in its entirety and insert the following in its place:

- "A. CONTRACTOR shall purchase and maintain, until final payment, property insurance upon the Work at the site in an amount equal to the total bid price for the completed construction. This insurance shall include the interests of OWNER, CONTRACTOR, Subcontractors, ENGINEER and ENGINEER's consultants in the Work, shall insure against the perils of fire and extended coverage, shall include "all risk" insurance for physical loss and damage including theft, vandalism and malicious mischief, collapse and water damage, and shall include damages, losses and expenses rising out of or resulting from any insured loss or incurred in the repair or replacement of any insured property (including but not limited to fees and charges of engineers, architects, attorneys and other professionals). This insurance shall be provided on the completed value form. If not covered under the "all risk" insurance or otherwise provided in these Supplementary Conditions, CONTRACTOR shall purchase and maintain similar property insurance on portions of the Work stored on and off the site or in transit when such portions of the Work are to be included in an Application for Payment."

Delete Paragraph 6.05.B of the General Conditions in its entirety and insert the following in its place:

- "B. All the policies of insurance (or the certificates or other evidence thereof) required to be purchased and maintained by CONTRACTOR in accordance with paragraphs 6.05 will contain a provision or endorsement that the coverage afforded will not be canceled or materially changed or renewal refused until at least thirty days' prior written notice has been given to OWNER by certified mail and will contain waiver provisions in accordance with paragraph 6.06.B."

**SC-6.05.D**

Delete Paragraph 6.05.D in its entirety and insert the following:

- "OWNER may occupy or use a portion of the Work prior to Substantial Completion."

**SC-6.06A**

Delete Paragraph 6.06A in its entirety and insert the following:

- "OWNER and CONTRACTOR intend that all policies of insurance purchased in accordance with the provisions of Article 6 will protect OWNER, CONTRACTOR, Subcontractors, and ENGINEER, and all other individuals or entities identified in the

Supplementary Conditions as loss payees (and officers, director, members, partners, employees, agents, consultants, and subcontractors or each and any of them) in such policies and will, where required to provided such insurance, provide primary coverage for all losses and damages caused by the perils or causes of loss covered thereby.”

#### **SC-6.06.C**

Delete Paragraph 6.06.C in its entirety and replace with the following:

“The CONTRACTOR shall pay for all costs not covered because of the application of a policy deductible due under any of its insurance policies required hereunder.”

#### **SC-6.07**

Delete paragraph 6.07.A of the General Conditions in its entirety.

Delete paragraph 6.07.B of the General Conditions in its entirety.

Delete paragraph 6.07.C of the General Conditions in its entirety.

### **ARTICLE 7. CONTRACTOR'S RESPONSIBILITIES**

#### **SC-7.01**

Add the following new paragraph as follows:

“7.01.C The site superintendent may be a direct employee of the subcontractor provided that this individual has the full authority and responsibility of the general contractor’s specified superintendent. The General Contractor shall submit a letter to the District and the Engineer stating who the supervisor is and defining his/her authority during all construction related activities.”

#### **SC-7.02.C – 7.02.G**

Insert the following new paragraphs immediately after Paragraph 7.02.B:

“C. Regular working hours are defined as Monday through Friday, excluding holidays, between the hours of 7:00 AM and 5:00 PM. Requests to work other than regular working hours shall be submitted to ENGINEER not less than 48 hours prior to any proposed change. Occasional unscheduled overtime on weekdays may be permitted provided it is approved by ENGINEER.”

“D. CONTRACTOR shall reimburse the OWNER for additional engineering and/or inspection costs incurred as a result of overtime work in excess of the regular working hours stipulated in Paragraph SC-7.02.C. At OWNER’s option, overtime costs may either be deducted from the CONTRACTOR’s monthly payment or deducted from the retainage held by OWNER until release of final payment. Overtime costs for the OWNER’s personnel shall be based on the individual’s current overtime wage rate. Overtime costs for personnel employed by the ENGINEER or OWNER’s independent testing laboratory shall be calculated in accordance with the terms of their respective contracts with the OWNER.”

- “E. This agreement is subject to the applicable provisions of the Contract Work Hours and Safety Standards Act, Public Law 87-581 87<sup>th</sup> Congress. No Contractor or Subcontractor contracting for any part of the Work shall require or permit any laborer or mechanic to be employed on the Work in excess of forty hours in any work week unless such laborer or mechanic receives compensation at a rate not less than one and one-half times that person’s basic rate of pay for all hours worked in excess of forty hours in such work week.”
- “F. CONTRACTOR and Subcontractors shall, insofar as practicable, give preference in the hiring of workers for the Project to qualified local residents with first preference being given to citizens of the United States who have served in the armed forces of the United States and have been honorably discharged therefrom or released from active duty therein.
- “G. CONTRACTOR shall employ only competent persons to do the work and whenever OWNER shall notify CONTRACTOR, in writing, that any person on the Work appears to be incompetent, disorderly, or otherwise unsatisfactory, such person shall be removed from the Project and shall not again be employed on it except with the consent of OWNER.”

#### **SC-7.04.A**

Insert the following at the end of the third sentence of Paragraph 7.04.A:

“, and in accordance with G.L. c.30, §39M.”

Add a new paragraph SC-7.04.A.1.c immediately after paragraph 7.04A.1.b, which is to read as follows:

- “c. It shall be CONTRACTOR’s responsibility to coordinate all submittals to ENGINEER for approval to eliminate any conflicts which might arise due to the use of “or equal” items. Any additional costs incidental to the use of “or equal” items shall be paid by CONTRACTOR.”

#### **SC-7.06**

Add the following to Paragraph 7.06.A:

“CONTRACTOR shall not employ any Subcontractor, Supplier or other person or organization, (including those who are to furnish the principal items of materials or equipment), whether initially or as a substitute, against whom OWNER makes reasonable objection. Acceptance of any Subcontractor, other person or organization by OWNER shall not constitute a waiver of any right of OWNER to reject defective Work.”

#### **7.06.H.1**

Add the following paragraph immediately after paragraph 7.06.H:

1. CONTRACTOR shall make payments to Subcontractors in accordance with Massachusetts General Laws Chapter 30, Section 39F.”

Add the following new paragraph as follows:

“7.06.J.1 OWNER or ENGINEER may furnish to any such Subcontractor, Supplier, or other person or organization, to the extent practicable, information about amounts paid to CONTRACTOR in accordance with CONTRACTOR’s Applications for Payment on account of the particular Subcontractor’s, Suppliers, other person’s, or other organization’s Work.”

**SC-7.06**

Add the following language at the beginning of paragraph 7.06.L of the General Conditions:

“Except as otherwise required by Massachusetts General Law, Chapter 149, Section 44F,”

**SC-7.07.A**

Delete the second sentence of Paragraph 7.07.A.

**SC-7.07.B**

Delete this subparagraph.

**SC-7.09**

Add the following language at the end of paragraph 7.09.A of the General Conditions:

“7.09.A.1 The materials and supplies to be used in the Work under this Contract are exempt from the Sales and Use Tax of the Commonwealth of Massachusetts. Contractor shall obtain the proper certificates, maintain the necessary records, and otherwise comply with all applicable requirements governing the exemption from sales tax.”

**SC-7.10C**

Delete the last sentence of Paragraph 7.10C.

**SC-7.11.B – C**

Insert the following new paragraphs immediately after Paragraph 7.11.A:

“B. The CONTRACTOR shall return to the ENGINEER one set of the Contract Drawings marked in colored pencil, showing all changes made during construction and including the location, by dimensions and elevations, of installed equipment, and underground facilities that will become concealed or buried by the construction. This shall include ties to all concealed work, etc. measured from permanent structures. Additionally, the CONTRACTOR shall be required to keep marked-up drawings current and on site and to provide mark-ups to the OWNER on a monthly basis.

“C. CONTRACTOR shall comply with all applicable provisions of Chapter 30, Section 39R of the Massachusetts General Laws regarding CONTRACTOR’s records.”

**SC-7.12.E**

Delete the text in parentheses in Paragraph 7.12.E.

#### **SC-7.16**

Add the following new paragraph immediately after paragraph 7.16.E of the General Conditions, which is to read as follows:

“7.16.F The accuracy of all such information submitted by the Contractor is the responsibility of the Contractor. In reviewing Shop Drawings, Samples, and similar submittals, the Engineer shall be entitled to rely upon the Contractor’s representation that such information is correct and accurate.”

#### **SC-7.17.E**

Add the following new paragraph 7.17.E, immediately after paragraph 7.17.D of the General Conditions:

“E. CONTRACTOR shall guarantee all materials and equipment furnished and Work performed for a period of two (2) years from the date of Substantial Completion. CONTRACTOR warrants and guarantees for a period of two (2) years from the date of Substantial Completion that the completed Work is free from all defects due to faulty materials or workmanship and CONTRACTOR shall promptly make such corrections as may be necessary by reason of any such defects including the repairs of any damage to other parts of the Work resulting from such defects. In the event that CONTRACTOR should fail to make such repairs, adjustments, or other work that may be made necessary by such defects, OWNER may do so and charge CONTRACTOR the cost thereby incurred. The Performance Bond shall remain in full force and effect through the guarantee period.”

#### **SC-7.18.A**

Delete the phrase in parentheses: “(other than the Work itself)” in Paragraph 7.18.A.

Change the phrase “negligent act or omission” to “negligent or willful or wrongful act or omission.”

#### **SC-7.18.B**

Insert the following at the end of Paragraph 7.18.B:

“If, through the acts or neglect of CONTRACTOR, any other Contractor or any Subcontractor shall suffer loss or damage on the Work, CONTRACTOR shall settle with such other Contractor or Subcontractor by agreement if such other Contractor or Subcontractor will so settle. If such other Contractor or Subcontractor shall assert any claim against OWNER on account of any damage alleged to have been sustained, OWNER shall notify CONTRACTOR, who shall indemnify and hold harmless OWNER against any such claims.”

### **ARTICLE 8. OTHER WORK AT THE SITE**

#### **SC-8.02**

Delete Paragraph 8.02 in its entirety.

**SC-8.03**

Delete paragraph 8.03.D of the General Conditions in its entirety, and insert the following in its place:

“8.03.D Should CONTRACTOR cause damage to the work or property of any separate contractor at the site, or should any claim arising out of CONTRACTOR'S performance of the Work at the site be made by any separate contractor against CONTRACTOR, OWNER, ENGINEER, ENGINEER'S Consultants, or any other person, CONTRACTOR shall promptly attempt to settle with such other contractor by agreement, or to otherwise resolve the dispute by arbitration or at law. CONTRACTOR shall, to the fullest extent permitted by Laws and Regulations, indemnify and hold OWNER, ENGINEER, and ENGINEER'S Consultants, harmless from and against all claims, damages, losses, and expenses (including, but not limited to, fees of engineers, architects, attorneys, and other professionals, and court and arbitration costs) arising directly, indirectly, or consequentially out of any action, legal or equitable, brought by any separate contractor against OWNER, ENGINEER, or ENGINEER'S Consultants, to the extent based on a claim arising out of the CONTRACTOR'S performance of the Work. Should a separate contractor cause damage to the Work or property of CONTRACTOR or should the performance of Work by any separate contractor at the site give rise to any other claim, CONTRACTOR shall not institute any action, legal or equitable, against OWNER, ENGINEER, or ENGINEER'S Consultants or permit any action against any of them to be maintained and continued in its name or for its benefit in any court or before any arbiter which seeks to impose liability on or to recover damages from OWNER, ENGINEER, or ENGINEER'S Consultants, on such action or claim. If CONTRACTOR is delayed at any time in performing or furnishing Work by any act or neglect of a separate contractor and OWNER and CONTRACTOR are unable to agree to the extent of any adjustment in Contract Times attributable thereto, CONTRACTOR may make a claim for an extension of times in accordance with Article 12.02. An extension of the Contract Times shall be CONTRACTOR'S exclusive remedy with respect to OWNER, ENGINEER, and ENGINEER'S Consultants, for any delay, disruption, interference or hindrance caused by any separate contractor. This paragraph does not prevent recovery from OWNER, ENGINEER, or ENGINEER'S Consultant, for activities that are their respective responsibilities.”

**ARTICLE 9.**

**OWNER'S RESPONSIBILITIES**

**SC-9.02.A**

Delete the phrase “provided Contractor makes no reasonable objection to the replacement engineer” in Paragraph 9.02.A.

**SC-9.06**

Delete paragraph 9.06 of the General Conditions in its entirety.

**SC-9.09**



Insert the following after the first sentence of Paragraph 9.09.A:

“However, the OWNER shall have the right to direct the CONTRACTOR to perform the Work according to any sequence schedule set forth in the Contract Documents or established pursuant thereto.”

## **ARTICLE 10. ENGINEER'S STATUS DURING CONSTRUCTION**

### **SC-10.01**

Add a new paragraph 10.01.B after paragraph 10.01.A of the General Conditions, which is to read as follows:

"B. Nothing contained in the Contract Documents shall be construed to create a contractual relationship of any kind (1) between the ENGINEER and CONTRACTOR, (2) between the OWNER and a Subcontractor or Subcontractors, or (3) between any person or entities other than the OWNER and CONTRACTOR. The ENGINEER shall, however, be entitled to performance and enforcement of obligations under the CONTRACT DOCUMENTS intended to facilitate performance of the ENGINEER'S duties."

### **SC-10.02B**

Insert the following at the end of Paragraph 10.02.B:

“However, the ENGINEER shall have the right to direct the CONTRACTOR to perform the Work according to any sequence schedule set forth in the Contract Documents or established pursuant thereto.”

### **SC-10.03**

Delete the last sentence of Paragraph 10.03.A

Add a new paragraph immediately after paragraph 10.03.A of the General Conditions as follows:

“10.03.B ENGINEER will furnish a Resident Project Representative and assistants to assist ENGINEER in observing the performance of the Work. The duties and responsibilities of the Resident Project Representative will be as enumerated in a document entitled "Duties, Responsibilities, and Limitations of the Authority of Resident Project Representative" and will be made available to CONTRACTOR at the start of his work.”

### **SC-10.08.B**

Insert the following after the first sentence in Paragraph 10.08.B:

“However, the ENGINEER shall have the right to direct the CONTRACTOR to perform the Work according to any sequence schedule set forth in the Contract Documents or established pursuant thereto.”

### **SC-10.08.F**

Add a new paragraph immediately after paragraph 10.08.E of the General Conditions which is to read as follows:

“ENGINEER'S interpretations will be made in accordance with Massachusetts General Laws Chapter 30, Section 39P.”

**ARTICLE 11. AMENDING THE CONTRACT DOCUMENTS; CHANGES IN THE WORK**

**SC-11.02**

Add a new paragraph immediately after paragraph 11.02.A of the General Conditions which is to read as follows:

“11.02.A.1 ENGINEER'S interpretations will be made in accordance with Massachusetts General Law, Chapter 30, Section 39P.”

**SC-11.02**

Add the following new paragraph immediately after paragraph 11.02.A of the General Conditions, which is to read as follows:

“11.02.B Upon request of the Owner or Engineer, the Contractor shall without cost to the Owner submit to the Engineer, in such form as the Engineer may require, an accurate written estimate of the cost of any such proposed extra Work or change. The estimate shall indicate the quantity and unit cost of each item of materials, and the number of hours of work and hourly rate for each class of labor, as well as the description and amounts of all other costs chargeable under the terms of this Article. Unit labor costs for the installation of each item of materials shall be shown if required by the Engineer. The Contractor shall promptly revise and resubmit such estimate if the Engineer determines that it is not in compliance with the requirements of this Article, or that it contains errors of facts or mathematical errors. If required by the Engineer, in order to establish the exact cost of new Work added or previously required Work omitted, the Contractor shall obtain and furnish to the Engineer bona fide proposals from recognized suppliers for furnishing any material included in such Work, and shall be furnished at Contractor's expense. The Contractor shall state in the estimate any extension of time required for the completion of the Work if the change or extra work is ordered.”

**SC-11.04**

In paragraph 11.04.C.2.a change “15 percent” to “10 percent”.

Delete paragraph 11.04.C.2.c

**ARTICLE 12. CLAIMS**

**SC-12.01**

Add a new paragraph immediately after paragraph 12.01.D.1 of the General Conditions to read as follows:

“12.01.D.1.a CONTRACTOR shall carry on the Work and maintain the progress schedule during the dispute resolution proceedings unless otherwise agreed in writing by OWNER and CONTRACTOR.”

**ARTICLE 13. COST OF THE WORK; ALLOWANCES; UNIT PRICE WORK**

**SC-13.01**

Add the following to the end of paragraph 13.01.B of the General Conditions to read as follows:

“Following the Notice of Award and prior to the execution of the AGREEMENT the OWNER, prospective contractor and, if any, each prospective filed subbid contractor shall agree on what percentage markup shall be used as direct labor costs in determination of extra work costs.”

In the second sentence of paragraph 13.01.B.1 delete the word "superintendents".

**SC-13.01.B.5**

Delete subparagraphs a, d, e, f, g, and h of Paragraph 13.01.B.5.

**SC-13.03.E**

Delete Paragraph 13.03.E in its entirety.

**SC-13.02**

Delete paragraph 13.02 of the General Conditions in its entirety.

**SC-13.03.E**

Delete Paragraph 13.03.E in its entirety.

**ARTICLE 14. TESTS AND INSPECTIONS; CORRECTION, REMOVAL OR ACCEPTANCE OF DEFECTIVE WORK**

**SC-14.02.F**

Delete the remainder of Paragraph 14.02.F after the words “Contractor’s expense.”

**SC-14.05.C.2**

Delete Paragraph 14.05.C.2 in its entirety.

**SC-14.06.B**

Insert the following new paragraph immediately after Paragraph 14.06.A:

“B. If Owner stops Work under paragraph 14.06.A, CONTRACTOR shall not be entitled to any extension of Contract Time or increase in Contract Price.”

**ARTICLE 15. PAYMENTS TO CONTRACTOR; SET-OFFS; COMPLETION;  
CORRECTION PERIOD**

**SC-15.01**

Delete the first phrase prior to the words “Contractor shall” in the first sentence of Paragraph 15.01.B.1 and insert the following:

“On a monthly basis and in accordance with G.L. c.30, §39G,”.

Delete paragraph 15.01.B.3 and insert the following in its place:

"15.01.B.3. Retainage with respect to progress payments will be five percent or, if stipulated, the maximum allowed by law."

**SC-15.01.B.4**

Insert the following new paragraph immediately after Paragraph 15.01.B.3:

“4. CONTRACTOR shall furnish evidence that payment received on the basis of materials and equipment not incorporated and suitably stored, has in fact been paid to the respective supplier(s) within ten (10) days of payment by OWNER. Failure to provide such evidence of payment may result in the withdrawal of previous approval(s) and removal of the cost of related materials and equipment from the next submitted Application for Payment.

**SC-15.01.C.1**

Delete Paragraph 15.01C.1 and insert the following:

“1. Progress Payments shall be made in accordance with Massachusetts General Laws, Chapter 30, Section 39G.”

**SC-15.01.D.1**

Delete Paragraph 15.01.D.1 and insert the following:

“1. Payment shall be made in accordance with G.L. c.30, §39G.”

**SC-15.01.E.2**

Delete the words “immediate” and “promptly” in the first sentence of Paragraph 15.01.E.2.

**SC-15.01.E.3**

Delete this Paragraph in its entirety.

### **SC-15.02**

Insert the following new paragraphs immediately after Paragraph 15.02.A:

- “B. No materials or supplies for the Work shall be purchased by CONTRACTOR or Subcontractor subject to any chattel mortgage or under a conditional sale contract or other agreement by which an interest is retained by the seller. CONTRACTOR warrants that CONTRACTOR has good title to all materials and supplies used by CONTRACTOR in the Work, free from all liens, claims or encumbrances.”
  
- “C. CONTRACTOR shall indemnify and save OWNER harmless from all claims growing out of the lawful demands of Subcontractors, laborers, workmen, mechanics, materialmen, and furnishers of machinery and parts thereof, equipment, power tools, and all supplies, including commissary, incurred in the furtherance of the performance of this Contract. CONTRACTOR shall, at OWNERS request, furnish satisfactory evidence that all obligations of the nature hereinabove designated have been paid, discharged, or waived. If CONTRACTOR fails to do so, then OWNER may, after having served written notice on the CONTRACTOR, either pay unpaid bills, of which OWNER has written notice, or withhold from the CONTRACTOR’s unpaid compensation a sum of money deemed reasonably sufficient to pay any and all such lawful claims until satisfactory evidence is furnished that all liabilities have been fully discharged whereupon payment to CONTRACTOR shall be resumed, in accordance with the terms of this Contract, but in no event shall the provisions of this sentence be construed to impose any obligation upon OWNER to either CONTRACTOR, or CONTRACTOR’s Surety. In paying any unpaid bills of the CONTRACTOR, OWNER’s payment shall be considered as payment made under the Contract by OWNER to CONTRACTOR and OWNER shall not be liable to CONTRACTOR for any such payment made in good faith.”

### **SC-15.03.C**

Delete the third sentence of Paragraph 15.03.C and insert the following:

“OWNER may review the preliminary certificate and make written objection to ENGINEER as to any provisions of the certificate or attached list.”

Delete the phrase “, within 14 days after submission of the preliminary certificate to OWNER,” in the fourth sentence of paragraph 15.03.C.

Delete the phrase “, within said 14 days,” in the fifth sentence of Paragraph 15.03.C.

### **SC-15.04.A**

Delete the phrase “subject to the following conditions” at the end of the first sentence of Paragraph 15.04.A.

Delete Paragraph 15.04.A.2 in its entirety.

#### **SC-15.06**

Delete Paragraph 15.06.B.1 and insert the following:

- “1. If, on the basis of ENGINEER’s observations of the Work during construction and final inspection, and ENGINEER’s review of the final Application for Payment and accompanying documentation, all as required by the Contract Documents, ENGINEER is satisfied that the Work has been completed and CONTRACTOR’s other obligations under the Contract Documents have been fulfilled, ENGINEER will indicate in writing ENGINEER’s recommendation of payment and present the Application for Payment to OWNER for payment. Thereupon ENGINEER will give written notice to OWNER and CONTRACTOR that the Work is acceptable subject to the provisions of paragraph 15.07. Otherwise, ENGINEER will return the Application for Payment to CONTRACTOR, indicating in writing the reasons for refusing to recommend final payment, in which case CONTRACTOR shall make the necessary corrections and resubmit the Application for Payment.

#### **SC-15.06.D**

Insert the following at the end of Paragraph 15.06.D:

“Final payment shall be made in accordance with G.L. c.30, §39G.”

### **ARTICLE 16. SUSPENSION OF WORK AND TERMINATION**

#### **SC-16.01.A**

Delete Paragraph 16.01.A in its entirety and insert the following:

- “A. OWNER may suspend the work or any portion thereof in accordance with G.L. c.30, §39O.”

#### **SC-16.02.A.5**

Insert new paragraph immediately after Paragraph 16.02.A.4:

- “5. If CONTRACTOR abandons the Work, or sublets this Contract or any part thereof, without the previous written consent of OWNER, or if the Contract or any claim thereunder shall be assigned by CONTRACTOR otherwise than as herein specified.”

#### **SC-16.03.A.1**

Delete the phrase “including fair and reasonable sums for overhead and profit on such Work” in Paragraph 16.03.A.1.

#### **SC-16.03.A.2**

Delete the phrase “plus fair and reasonable sums for overhead and profit on such expenses” in Paragraph 16.03.A.2.

**SC-16.03.A.3**

Delete Paragraph 16.03.A.3 in its entirety.

**SC-16.04.B**

Delete the last sentence of Paragraph 16.04.B.

**ARTICLE 17. FINAL RESOLUTION OF DISPUTES**

**SC-17.01.C**

Insert a new sub-paragraph after Paragraph 17.01.B:

“CONTRACTOR shall be responsible to carry on the Work and maintain the progress schedule during the dispute resolution proceedings.”

**SC-17.02**

Add a new paragraph immediately after Paragraph 17.01 of the General Conditions which is to read as follows:

“17.02 Venue

Any legal action relating to this Contract shall be filed in the Superior Court for the County in the Commonwealth of Massachusetts in which the Project is located, unless otherwise agreed by CONTRACTOR and OWNER in writing.”

**ARTICLE 18. MISCELLANEOUS**

**SC-18.08**

18.08 Headings:

Delete paragraph 18.08.A and replace with the following paragraph:

“18.08.A The headings or titles of any article, paragraph, subparagraph, section, subsection, or part of the Contract Documents shall not be deemed to limit or restrict the article, paragraph, section, or part.”

**SC-18.10**

Insert the following new paragraph:

“SC-18.10 Wage Rates

- “A. The requirements and provisions of all applicable laws and any amendments thereof or additions thereto as to employment of labor, and to the schedule of minimum wage rates established in compliance with laws shall be a part of the Contract Documents. If after the Notice of Award, it becomes necessary to employ any person in a trade or occupation not classified in the wage determinations, such person shall be paid at not less than such rates as shall be determined by the officials administering the laws mentioned above.”
- “B. The schedule of wages referred to above is minimum rates only, and OWNER will not consider any claims for additional compensation made by CONTRACTOR because of payment by CONTRACTOR of any wage in excess of the applicable, required rates.”
- “C. The said schedules of wages shall continue to be the minimum rates to be paid during the life of this Agreement, unless state laws and regulations require updating the same in which case the Owner shall provide the updated applicable schedule of wages, and a legible copy of said schedules shall be kept posted in a conspicuous place at the site of the work.”



ATTACHMENT A - WAGE RATES AND CERTIFICATE OF COMPLIANCE



**THE COMMONWEALTH OF MASSACHUSETTS  
EXECUTIVE OFFICE OF LABOR AND WORKFORCE DEVELOPMENT  
DEPARTMENT OF LABOR STANDARDS**

**Prevailing Wage Rates**

**As determined by the Director under the provisions of the  
Massachusetts General Laws, Chapter 149, Sections 26 to 27H**

CHARLES D. BAKER  
Governor

KARYN E. POLITO  
Lt. Governor

ROSALIN ACOSTA  
Secretary  
MICHAEL FLANAGAN  
Director

**Awarding Authority:** Town of Dedham

**Contract Number:** \_\_\_\_\_ **City/Town:** DEDHAM

**Description of Work:** The Work consists of various forms of asphalt paving and resurfacing including but not limited to full depth reclamation, mill & overlay and other misc related work.

**Job Location:** Various Locations

Information about Prevailing Wage Schedules for Awarding Authorities and Contractors

- This wage schedule applies only to the specific project referenced at the top of this page and uniquely identified by the “Wage Request Number” on all pages of this schedule.
- An Awarding Authority must request an updated wage schedule from the Department of Labor Standards (“DLS”) if it has not opened bids or selected a contractor within 90 days of the date of issuance of the wage schedule. For CM AT RISK projects (bid pursuant to G.L. c.149A), the earlier of: (a) the execution date of the GMP Amendment, or (b) the bid for the first construction scope of work must be within 90-days of the wage schedule issuance date.
- The wage schedule shall be incorporated in any advertisement or call for bids for the project as required by M.G.L. c. 149, § 27. The wage schedule shall be made a part of the contract awarded for the project. The wage schedule must be posted in a conspicuous place at the work site for the life of the project in accordance with M.G.L. c. 149 § 27. The wages listed on the wage schedule must be paid to employees performing construction work on the project whether they are employed by the prime contractor, a filed sub-bidder, or any sub-contractor.
- All apprentices working on the project are required to be registered with the Massachusetts Department of Labor Standards, Division of Apprentice Standards (DLS/DAS). Apprentice must keep his/her apprentice identification card on his/her person during all work hours on the project. An apprentice registered with DAS may be paid the lower apprentice wage rate at the applicable step as provided on the prevailing wage schedule. **Any apprentice not registered with DLS/DAS regardless of whether or not they are registered with any other federal, state, local, or private agency must be paid the journeyworker's rate for the trade.**
- The wage rates will remain in effect for the duration of the project, except in the case of multi-year public construction projects. For construction projects lasting longer than one year, awarding authorities must request an updated wage schedule. Awarding authorities are required to request these updates no later than two weeks before the anniversary of the date the contract was executed by the awarding authority and the general contractor. For multi-year CM AT RISK projects, awarding authority must request an annual update no later than two weeks before the anniversary date, determined as the earlier of: (a) the execution date of the GMP Amendment, or (b) the execution date of the first amendment to permit procurement of construction services. Contractors are required to obtain the wage schedules from awarding authorities, and to pay no less than these rates to covered workers. The annual update requirement is not applicable to 27F “rental of equipment” contracts.
- Every contractor or subcontractor which performs construction work on the project is required to submit weekly payroll reports and a Statement of Compliance directly to the awarding authority by mail or email and keep them on file for three years. Each weekly payroll report must contain: the employee’s name, address, occupational classification, hours worked, and wages paid. Do not submit weekly payroll reports to DLS. A sample of a payroll reporting form may be obtained at <http://www.mass.gov/dols/pw>.
- Contractors with questions about the wage rates or classifications included on the wage schedule have an affirmative obligation to inquire with DLS at (617) 626-6953.
- Employees not receiving the prevailing wage rate set forth on the wage schedule may report the violation to the Fair Labor Division of the office of the Attorney General at (617) 727-3465.
- Failure of a contractor or subcontractor to pay the prevailing wage rates listed on the wage schedule to all employees who perform construction work on the project is a violation of the law and subjects the contractor or subcontractor to civil and criminal penalties.

Classification	Effective Date	Base Wage	Health	Pension	Supplemental Unemployment	Total Rate
<b>Construction</b>						
(2 AXLE) DRIVER - EQUIPMENT <i>TEAMSTERS JOINT COUNCIL NO. 10 ZONE A</i>	12/01/2021	\$37.05	\$13.41	\$16.01	\$0.00	\$66.47
(3 AXLE) DRIVER - EQUIPMENT <i>TEAMSTERS JOINT COUNCIL NO. 10 ZONE A</i>	12/01/2021	\$37.12	\$13.41	\$16.01	\$0.00	\$66.54
(4 & 5 AXLE) DRIVER - EQUIPMENT <i>TEAMSTERS JOINT COUNCIL NO. 10 ZONE A</i>	12/01/2021	\$37.24	\$13.41	\$16.01	\$0.00	\$66.66
ADS/SUBMERSIBLE PILOT <i>PILE DRIVER LOCAL 56 (ZONE 1)</i>	08/01/2020	\$103.05	\$9.40	\$23.12	\$0.00	\$135.57
For apprentice rates see "Apprentice- PILE DRIVER"						
AIR TRACK OPERATOR <i>LABORERS - ZONE 1</i>	12/01/2021	\$41.93	\$9.10	\$17.57	\$0.00	\$68.60
	06/01/2022	\$42.93	\$9.10	\$17.57	\$0.00	\$69.60
	12/01/2022	\$43.93	\$9.10	\$17.57	\$0.00	\$70.60
	06/01/2023	\$44.93	\$9.10	\$17.57	\$0.00	\$71.60
	12/01/2023	\$46.18	\$9.10	\$17.57	\$0.00	\$72.85
For apprentice rates see "Apprentice- LABORER"						
AIR TRACK OPERATOR (HEAVY & HIGHWAY) <i>LABORERS - ZONE 1 (HEAVY &amp; HIGHWAY)</i>	12/01/2021	\$41.93	\$9.10	\$17.57	\$0.00	\$68.60
For apprentice rates see "Apprentice- LABORER (Heavy and Highway)"						
ASBESTOS REMOVER - PIPE / MECH. EQUIPT. <i>HEAT &amp; FROST INSULATORS LOCAL 6 (BOSTON)</i>	12/01/2020	\$38.10	\$12.80	\$9.45	\$0.00	\$60.35
ASPHALT RAKER <i>LABORERS - ZONE 1</i>	12/01/2021	\$41.43	\$9.10	\$17.57	\$0.00	\$68.10
	06/01/2022	\$42.43	\$9.10	\$17.57	\$0.00	\$69.10
	12/01/2022	\$43.43	\$9.10	\$17.57	\$0.00	\$70.10
	06/01/2023	\$44.43	\$9.10	\$17.57	\$0.00	\$71.10
	12/01/2023	\$45.68	\$9.10	\$17.57	\$0.00	\$72.35
For apprentice rates see "Apprentice- LABORER"						
ASPHALT RAKER (HEAVY & HIGHWAY) <i>LABORERS - ZONE 1 (HEAVY &amp; HIGHWAY)</i>	12/01/2021	\$41.43	\$9.10	\$17.57	\$0.00	\$68.10
For apprentice rates see "Apprentice- LABORER (Heavy and Highway)"						
ASPHALT/CONCRETE/CRUSHER PLANT-ON SITE <i>OPERATING ENGINEERS LOCAL 4</i>	12/01/2021	\$51.38	\$14.00	\$16.05	\$0.00	\$81.43
For apprentice rates see "Apprentice- OPERATING ENGINEERS"						
BACKHOE/FRONT-END LOADER <i>OPERATING ENGINEERS LOCAL 4</i>	12/01/2021	\$51.38	\$14.00	\$16.05	\$0.00	\$81.43
For apprentice rates see "Apprentice- OPERATING ENGINEERS"						
BARCO-TYPE JUMPING TAMPER <i>LABORERS - ZONE 1</i>	12/01/2021	\$41.43	\$9.10	\$17.57	\$0.00	\$68.10
	06/01/2022	\$42.43	\$9.10	\$17.57	\$0.00	\$69.10
	12/01/2022	\$43.43	\$9.10	\$17.57	\$0.00	\$70.10
	06/01/2023	\$44.43	\$9.10	\$17.57	\$0.00	\$71.10
	12/01/2023	\$45.68	\$9.10	\$17.57	\$0.00	\$72.35
For apprentice rates see "Apprentice- LABORER"						
BLOCK PAVER, RAMMER / CURB SETTER <i>LABORERS - ZONE 1</i>	12/01/2021	\$41.93	\$9.10	\$17.57	\$0.00	\$68.60
	06/01/2022	\$42.93	\$9.10	\$17.57	\$0.00	\$69.60
	12/01/2022	\$43.93	\$9.10	\$17.57	\$0.00	\$70.60
	06/01/2023	\$44.93	\$9.10	\$17.57	\$0.00	\$71.60
	12/01/2023	\$46.18	\$9.10	\$17.57	\$0.00	\$72.85
For apprentice rates see "Apprentice- LABORER"						

Classification	Effective Date	Base Wage	Health	Pension	Supplemental Unemployment	Total Rate
BLOCK PAVER, RAMMER / CURB SETTER (HEAVY & HIGHWAY) <i>LABORERS - ZONE 1 (HEAVY &amp; HIGHWAY)</i> For apprentice rates see "Apprentice- LABORER (Heavy and Highway)	12/01/2021	\$41.93	\$9.10	\$17.57	\$0.00	\$68.60
BOILER MAKER <i>BOILERMAKERS LOCAL 29</i>	01/01/2020	\$46.10	\$7.07	\$17.98	\$0.00	\$71.15

**Apprentice - BOILERMAKER - Local 29**

**Effective Date - 01/01/2020**

Step	percent	Apprentice Base Wage	Health	Pension	Supplemental Unemployment	Total Rate
1	65	\$29.97	\$7.07	\$11.69	\$0.00	\$48.73
2	65	\$29.97	\$7.07	\$11.69	\$0.00	\$48.73
3	70	\$32.27	\$7.07	\$12.59	\$0.00	\$51.93
4	75	\$34.58	\$7.07	\$13.49	\$0.00	\$55.14
5	80	\$36.88	\$7.07	\$14.38	\$0.00	\$58.33
6	85	\$39.19	\$7.07	\$15.29	\$0.00	\$61.55
7	90	\$41.49	\$7.07	\$16.18	\$0.00	\$64.74
8	95	\$43.80	\$7.07	\$17.09	\$0.00	\$67.96

**Notes:**

**Apprentice to Journeyworker Ratio:1:4**

BRICK/STONE/ARTIFICIAL MASONRY (INCL. MASONRY WATERPROOFING) <i>BRICKLAYERS LOCAL 3 (FOXBORO)</i>	08/01/2021	\$55.01	\$11.39	\$21.57	\$0.00	\$87.97
	02/01/2022	\$55.01	\$11.39	\$21.65	\$0.00	\$88.05

**Apprentice - BRICK/PLASTER/CEMENT MASON - Local 3 Foxboro**

**Effective Date - 08/01/2021**

Step	percent	Apprentice Base Wage	Health	Pension	Supplemental Unemployment	Total Rate
1	50	\$27.51	\$11.39	\$21.57	\$0.00	\$60.47
2	60	\$33.01	\$11.39	\$21.57	\$0.00	\$65.97
3	70	\$38.51	\$11.39	\$21.57	\$0.00	\$71.47
4	80	\$44.01	\$11.39	\$21.57	\$0.00	\$76.97
5	90	\$49.51	\$11.39	\$21.57	\$0.00	\$82.47

**Effective Date - 02/01/2022**

Step	percent	Apprentice Base Wage	Health	Pension	Supplemental Unemployment	Total Rate
1	50	\$27.51	\$11.39	\$21.65	\$0.00	\$60.55
2	60	\$33.01	\$11.39	\$21.65	\$0.00	\$66.05
3	70	\$38.51	\$11.39	\$21.65	\$0.00	\$71.55
4	80	\$44.01	\$11.39	\$21.65	\$0.00	\$77.05
5	90	\$49.51	\$11.39	\$21.65	\$0.00	\$82.55

**Notes:**

**Apprentice to Journeyworker Ratio:1:5**

BULLDOZER/GRADER/SCRAPER OPERATING ENGINEERS LOCAL 4	12/01/2021	\$50.83	\$14.00	\$16.05	\$0.00	\$80.88
---	------------	---------	---------	---------	--------	---------

For apprentice rates see "Apprentice- OPERATING ENGINEERS"

CAISSON & UNDERPINNING BOTTOM MAN LABORERS - FOUNDATION AND MARINE	12/01/2021	\$42.33	\$9.10	\$17.72	\$0.00	\$69.15
---	------------	---------	--------	---------	--------	---------

For apprentice rates see "Apprentice- LABORER"

CAISSON & UNDERPINNING LABORER LABORERS - FOUNDATION AND MARINE	12/01/2021	\$41.18	\$9.10	\$17.72	\$0.00	\$68.00
--	------------	---------	--------	---------	--------	---------

For apprentice rates see "Apprentice- LABORER"

CAISSON & UNDERPINNING TOP MAN LABORERS - FOUNDATION AND MARINE	12/01/2021	\$41.18	\$9.10	\$17.72	\$0.00	\$68.00
--	------------	---------	--------	---------	--------	---------

For apprentice rates see "Apprentice- LABORER"

CARBIDE CORE DRILL OPERATOR LABORERS - ZONE 1	12/01/2021	\$41.43	\$9.10	\$17.57	\$0.00	\$68.10
--	------------	---------	--------	---------	--------	---------

	06/01/2022	\$42.43	\$9.10	\$17.57	\$0.00	\$69.10
--	------------	---------	--------	---------	--------	---------

	12/01/2022	\$43.43	\$9.10	\$17.57	\$0.00	\$70.10
--	------------	---------	--------	---------	--------	---------

	06/01/2023	\$44.43	\$9.10	\$17.57	\$0.00	\$71.10
--	------------	---------	--------	---------	--------	---------

	12/01/2023	\$45.68	\$9.10	\$17.57	\$0.00	\$72.35
--	------------	---------	--------	---------	--------	---------

For apprentice rates see "Apprentice- LABORER"

CARPENTER CARPENTERS -ZONE 1 (Metro Boston)	09/01/2021	\$53.27	\$8.58	\$19.82	\$0.00	\$81.67
--	------------	---------	--------	---------	--------	---------

	03/01/2022	\$54.12	\$8.58	\$19.82	\$0.00	\$82.52
--	------------	---------	--------	---------	--------	---------

	09/01/2022	\$55.02	\$8.58	\$19.82	\$0.00	\$83.42
--	------------	---------	--------	---------	--------	---------

	03/01/2023	\$55.87	\$8.58	\$19.82	\$0.00	\$84.27
--	------------	---------	--------	---------	--------	---------

**Classification**

**Effective Date    Base Wage    Health    Pension    Supplemental Unemployment    Total Rate**

**Apprentice - CARPENTER - Zone 1 Metro Boston**

**Effective Date - 09/01/2021**

Step	percent	Apprentice Base Wage	Health	Pension	Supplemental Unemployment	Total Rate
1	50	\$26.64	\$8.58	\$1.73	\$0.00	\$36.95
2	60	\$31.96	\$8.58	\$1.73	\$0.00	\$42.27
3	70	\$37.29	\$8.58	\$14.63	\$0.00	\$60.50
4	75	\$39.95	\$8.58	\$14.63	\$0.00	\$63.16
5	80	\$42.62	\$8.58	\$16.36	\$0.00	\$67.56
6	80	\$42.62	\$8.58	\$16.36	\$0.00	\$67.56
7	90	\$47.94	\$8.58	\$18.09	\$0.00	\$74.61
8	90	\$47.94	\$8.58	\$18.09	\$0.00	\$74.61

**Effective Date - 03/01/2022**

Step	percent	Apprentice Base Wage	Health	Pension	Supplemental Unemployment	Total Rate
1	50	\$27.06	\$8.58	\$1.73	\$0.00	\$37.37
2	60	\$32.47	\$8.58	\$1.73	\$0.00	\$42.78
3	70	\$37.88	\$8.58	\$14.63	\$0.00	\$61.09
4	75	\$40.59	\$8.58	\$14.63	\$0.00	\$63.80
5	80	\$43.30	\$8.58	\$16.36	\$0.00	\$68.24
6	80	\$43.30	\$8.58	\$16.36	\$0.00	\$68.24
7	90	\$48.71	\$8.58	\$18.09	\$0.00	\$75.38
8	90	\$48.71	\$8.58	\$18.09	\$0.00	\$75.38

**Notes:**  
 % Indentured After 10/1/17; 45/45/55/55/70/70/80/80  
 Step 1&2 \$34.28/ 3&4 \$41.28/ 5&6 \$62.23/ 7&8 \$69.29

**Apprentice to Journeyworker Ratio:1:5**

CARPENTER WOOD FRAME	04/01/2021	\$27.87	\$7.21	\$5.80	\$0.00	\$40.88
CARPENTERS -ZONE 2 (Wood Frame)	04/01/2022	\$28.62	\$7.21	\$5.80	\$0.00	\$41.63
	04/01/2023	\$28.97	\$7.21	\$5.80	\$0.00	\$41.98

All Aspects of New Wood Frame Work

**Classification**

**Effective Date   Base Wage   Health   Pension   Supplemental Unemployment   Total Rate**

**Apprentice - CARPENTER (Wood Frame) - Zone 2**

**Effective Date - 04/01/2021**

Step	percent	Apprentice Base Wage	Health	Pension	Supplemental Unemployment	Total Rate
1	50	\$13.94	\$7.21	\$0.00	\$0.00	\$21.15
2	50	\$13.94	\$7.21	\$0.00	\$0.00	\$21.15
3	55	\$15.33	\$7.21	\$2.00	\$0.00	\$24.54
4	55	\$15.33	\$7.21	\$2.00	\$0.00	\$24.54
5	70	\$19.51	\$7.21	\$5.80	\$0.00	\$32.52
6	70	\$19.51	\$7.21	\$5.80	\$0.00	\$32.52
7	80	\$22.30	\$7.21	\$5.80	\$0.00	\$35.31
8	80	\$22.30	\$7.21	\$5.80	\$0.00	\$35.31

**Effective Date - 04/01/2022**

Step	percent	Apprentice Base Wage	Health	Pension	Supplemental Unemployment	Total Rate
1	50	\$14.31	\$7.21	\$0.00	\$0.00	\$21.52
2	50	\$14.31	\$7.21	\$0.00	\$0.00	\$21.52
3	55	\$15.74	\$7.21	\$2.00	\$0.00	\$24.95
4	55	\$15.74	\$7.21	\$2.00	\$0.00	\$24.95
5	70	\$20.03	\$7.21	\$5.80	\$0.00	\$33.04
6	70	\$20.03	\$7.21	\$5.80	\$0.00	\$33.04
7	80	\$22.90	\$7.21	\$5.80	\$0.00	\$35.91
8	80	\$22.90	\$7.21	\$5.80	\$0.00	\$35.91

**Notes:**

% Indentured After 10/1/17; 45/45/55/55/70/70/80/80  
 Step 1&2 \$19.75/ 3&4 \$24.54/ 5&6 \$32.52/ 7&8 \$35.31

**Apprentice to Journeyworker Ratio:1:5**

CEMENT MASONRY/PLASTERING BRICKLAYERS LOCAL 3 (FOXBORO)	01/01/2020	\$44.67	\$12.75	\$22.41	\$0.62	\$80.45
--	------------	---------	---------	---------	--------	---------

**Apprentice - CEMENT MASONRY/PLASTERING - Foxboro**

**Effective Date - 01/01/2020**

Step	percent	Apprentice Base Wage	Health	Pension	Supplemental Unemployment	Total Rate
1	50	\$22.34	\$12.75	\$15.41	\$0.00	\$50.50
2	60	\$26.80	\$12.75	\$17.41	\$0.62	\$57.58
3	65	\$29.04	\$12.75	\$18.41	\$0.62	\$60.82
4	70	\$31.27	\$12.75	\$19.41	\$0.62	\$64.05
5	75	\$33.50	\$12.75	\$20.41	\$0.62	\$67.28
6	80	\$35.74	\$12.75	\$21.41	\$0.62	\$70.52
7	90	\$40.20	\$12.75	\$22.41	\$0.62	\$75.98

**Notes:**

Steps 3,4 are 500 hrs. All other steps are 1,000 hrs.

**Apprentice to Journeyworker Ratio:1:3**

<b>Classification</b>	<b>Effective Date</b>	<b>Base Wage</b>	<b>Health</b>	<b>Pension</b>	<b>Supplemental Unemployment</b>	<b>Total Rate</b>
<b>CHAIN SAW OPERATOR</b> <i>LABORERS - ZONE 1</i>	12/01/2021	\$41.43	\$9.10	\$17.57	\$0.00	\$68.10
	06/01/2022	\$42.43	\$9.10	\$17.57	\$0.00	\$69.10
	12/01/2022	\$43.43	\$9.10	\$17.57	\$0.00	\$70.10
	06/01/2023	\$44.43	\$9.10	\$17.57	\$0.00	\$71.10
	12/01/2023	\$45.68	\$9.10	\$17.57	\$0.00	\$72.35
For apprentice rates see "Apprentice- LABORER"						
<b>CLAM SHELLS/SLURRY BUCKETS/HEADING MACHINES</b> <i>OPERATING ENGINEERS LOCAL 4</i>	12/01/2021	\$52.38	\$14.00	\$16.05	\$0.00	\$82.43
For apprentice rates see "Apprentice- OPERATING ENGINEERS"						
<b>COMPRESSOR OPERATOR</b> <i>OPERATING ENGINEERS LOCAL 4</i>	12/01/2021	\$33.69	\$14.00	\$16.05	\$0.00	\$63.74
For apprentice rates see "Apprentice- OPERATING ENGINEERS"						
<b>DELEADER (BRIDGE)</b> <i>PAINTERS LOCAL 35 - ZONE 1</i>	01/01/2022	\$53.66	\$8.65	\$23.05	\$0.00	\$85.36
	07/01/2022	\$54.86	\$8.65	\$23.05	\$0.00	\$86.56
	01/01/2023	\$56.06	\$8.65	\$23.05	\$0.00	\$87.76
	07/01/2023	\$57.26	\$8.65	\$23.05	\$0.00	\$88.96
	01/01/2024	\$58.46	\$8.65	\$23.05	\$0.00	\$90.16
	07/01/2024	\$59.66	\$8.65	\$23.05	\$0.00	\$91.36
	01/01/2025	\$60.86	\$8.65	\$23.05	\$0.00	\$92.56



**Classification**

**Effective Date    Base Wage    Health    Pension    Supplemental Unemployment    Total Rate**

**Apprentice - PAINTER Local 35 - BRIDGES/TANKS**

**Effective Date - 01/01/2022**

Step	percent	Apprentice Base Wage	Health	Pension	Supplemental Unemployment	Total Rate
1	50	\$26.83	\$8.65	\$0.00	\$0.00	\$35.48
2	55	\$29.51	\$8.65	\$6.27	\$0.00	\$44.43
3	60	\$32.20	\$8.65	\$6.84	\$0.00	\$47.69
4	65	\$34.88	\$8.65	\$7.41	\$0.00	\$50.94
5	70	\$37.56	\$8.65	\$19.63	\$0.00	\$65.84
6	75	\$40.25	\$8.65	\$20.20	\$0.00	\$69.10
7	80	\$42.93	\$8.65	\$20.77	\$0.00	\$72.35
8	90	\$48.29	\$8.65	\$21.91	\$0.00	\$78.85

**Effective Date - 07/01/2022**

Step	percent	Apprentice Base Wage	Health	Pension	Supplemental Unemployment	Total Rate
1	50	\$27.43	\$8.65	\$0.00	\$0.00	\$36.08
2	55	\$30.17	\$8.65	\$6.27	\$0.00	\$45.09
3	60	\$32.92	\$8.65	\$6.84	\$0.00	\$48.41
4	65	\$35.66	\$8.65	\$7.41	\$0.00	\$51.72
5	70	\$38.40	\$8.65	\$19.63	\$0.00	\$66.68
6	75	\$41.15	\$8.65	\$20.20	\$0.00	\$70.00
7	80	\$43.89	\$8.65	\$20.77	\$0.00	\$73.31
8	90	\$49.37	\$8.65	\$21.91	\$0.00	\$79.93

**Notes:**

Steps are 750 hrs.

**Apprentice to Journeyworker Ratio:1:1**

DEMO: ADZEMAN LABORERS - ZONE 1	12/01/2021	\$41.33	\$9.10	\$17.57	\$0.00	\$68.00
	06/01/2022	\$42.33	\$9.10	\$17.57	\$0.00	\$69.00
	12/01/2022	\$43.33	\$9.10	\$17.57	\$0.00	\$70.00
	06/01/2023	\$44.33	\$9.10	\$17.57	\$0.00	\$71.00
	12/01/2023	\$45.58	\$9.10	\$17.57	\$0.00	\$72.25

For apprentice rates see "Apprentice- LABORER"

DEMO: BACKHOE/LOADER/HAMMER OPERATOR LABORERS - ZONE 1	12/01/2021	\$42.33	\$9.10	\$17.57	\$0.00	\$69.00
	06/01/2022	\$43.33	\$9.10	\$17.57	\$0.00	\$70.00
	12/01/2022	\$44.33	\$9.10	\$17.57	\$0.00	\$71.00
	06/01/2023	\$45.33	\$9.10	\$17.57	\$0.00	\$72.00
	12/01/2023	\$46.58	\$9.10	\$17.57	\$0.00	\$73.25

For apprentice rates see "Apprentice- LABORER"

DEMO: BURNERS LABORERS - ZONE 1	12/01/2021	\$42.08	\$9.10	\$17.57	\$0.00	\$68.75
	06/01/2022	\$43.08	\$9.10	\$17.57	\$0.00	\$69.75
	12/01/2022	\$44.08	\$9.10	\$17.57	\$0.00	\$70.75
	06/01/2023	\$45.08	\$9.10	\$17.57	\$0.00	\$71.75
	12/01/2023	\$46.33	\$9.10	\$17.57	\$0.00	\$73.00

For apprentice rates see "Apprentice- LABORER"

<b>Classification</b>	<b>Effective Date</b>	<b>Base Wage</b>	<b>Health</b>	<b>Pension</b>	<b>Supplemental Unemployment</b>	<b>Total Rate</b>
DEMO: CONCRETE CUTTER/SAWYER <i>LABORERS - ZONE 1</i>	12/01/2021	\$42.33	\$9.10	\$17.57	\$0.00	\$69.00
	06/01/2022	\$43.33	\$9.10	\$17.57	\$0.00	\$70.00
	12/01/2022	\$44.33	\$9.10	\$17.57	\$0.00	\$71.00
	06/01/2023	\$45.33	\$9.10	\$17.57	\$0.00	\$72.00
	12/01/2023	\$46.58	\$9.10	\$17.57	\$0.00	\$73.25
For apprentice rates see "Apprentice- LABORER"						
DEMO: JACKHAMMER OPERATOR <i>LABORERS - ZONE 1</i>	12/01/2021	\$42.08	\$9.10	\$17.57	\$0.00	\$68.75
	06/01/2022	\$43.08	\$9.10	\$17.57	\$0.00	\$69.75
	12/01/2022	\$44.08	\$9.10	\$17.57	\$0.00	\$70.75
	06/01/2023	\$45.08	\$9.10	\$17.57	\$0.00	\$71.75
	12/01/2023	\$46.33	\$9.10	\$17.57	\$0.00	\$73.00
For apprentice rates see "Apprentice- LABORER"						
DEMO: WRECKING LABORER <i>LABORERS - ZONE 1</i>	12/01/2021	\$41.33	\$9.10	\$17.57	\$0.00	\$68.00
	06/01/2022	\$42.33	\$9.10	\$17.57	\$0.00	\$69.00
	12/01/2022	\$43.33	\$9.10	\$17.57	\$0.00	\$70.00
	06/01/2023	\$44.33	\$9.10	\$17.57	\$0.00	\$71.00
	12/01/2023	\$45.58	\$9.10	\$17.57	\$0.00	\$72.25
For apprentice rates see "Apprentice- LABORER"						
DIRECTIONAL DRILL MACHINE OPERATOR <i>OPERATING ENGINEERS LOCAL 4</i>	12/01/2021	\$50.83	\$14.00	\$16.05	\$0.00	\$80.88
For apprentice rates see "Apprentice- OPERATING ENGINEERS"						
DIVER <i>PILE DRIVER LOCAL 56 (ZONE 1)</i>	08/01/2020	\$68.70	\$9.40	\$23.12	\$0.00	\$101.22
For apprentice rates see "Apprentice- PILE DRIVER"						
DIVER TENDER <i>PILE DRIVER LOCAL 56 (ZONE 1)</i>	08/01/2020	\$49.07	\$9.40	\$23.12	\$0.00	\$81.59
For apprentice rates see "Apprentice- PILE DRIVER"						
DIVER TENDER (EFFLUENT) <i>PILE DRIVER LOCAL 56 (ZONE 1)</i>	08/01/2020	\$73.60	\$9.40	\$23.12	\$0.00	\$106.12
For apprentice rates see "Apprentice- PILE DRIVER"						
DIVER/SLURRY (EFFLUENT) <i>PILE DRIVER LOCAL 56 (ZONE 1)</i>	08/01/2020	\$103.05	\$9.40	\$23.12	\$0.00	\$135.57
For apprentice rates see "Apprentice- PILE DRIVER"						
DRAWBRIDGE OPERATOR (Construction) <i>DRAWBRIDGE - SEIU LOCAL 888</i>	07/01/2020	\$26.77	\$6.67	\$3.93	\$0.16	\$37.53
ELECTRICIAN <i>ELECTRICIANS LOCAL 103</i>	09/01/2021	\$56.36	\$13.00	\$20.54	\$0.00	\$89.90
	03/01/2022	\$57.32	\$13.00	\$20.82	\$0.00	\$91.14
	09/01/2022	\$58.76	\$13.00	\$20.86	\$0.00	\$92.62
	03/01/2023	\$60.43	\$13.00	\$20.91	\$0.00	\$94.34

**Classification**

**Effective Date   Base Wage   Health   Pension   Supplemental Unemployment   Total Rate**

**Apprentice - ELECTRICIAN - Local 103**

**Effective Date - 09/01/2021**

Step	percent	Apprentice Base Wage	Health	Pension	Supplemental Unemployment	Total Rate
1	40	\$22.54	\$13.00	\$0.68	\$0.00	\$36.22
2	40	\$22.54	\$13.00	\$0.68	\$0.00	\$36.22
3	45	\$25.36	\$13.00	\$15.36	\$0.00	\$53.72
4	45	\$25.36	\$13.00	\$15.36	\$0.00	\$53.72
5	50	\$28.18	\$13.00	\$15.84	\$0.00	\$57.02
6	55	\$31.00	\$13.00	\$16.31	\$0.00	\$60.31
7	60	\$33.82	\$13.00	\$16.77	\$0.00	\$63.59
8	65	\$36.63	\$13.00	\$17.25	\$0.00	\$66.88
9	70	\$39.45	\$13.00	\$17.71	\$0.00	\$70.16
10	75	\$42.27	\$13.00	\$18.19	\$0.00	\$73.46

**Effective Date - 03/01/2022**

Step	percent	Apprentice Base Wage	Health	Pension	Supplemental Unemployment	Total Rate
1	40	\$22.93	\$13.00	\$0.69	\$0.00	\$36.62
2	40	\$22.93	\$13.00	\$0.69	\$0.00	\$36.62
3	45	\$25.79	\$13.00	\$15.62	\$0.00	\$54.41
4	45	\$25.79	\$13.00	\$15.62	\$0.00	\$54.41
5	50	\$28.66	\$13.00	\$16.10	\$0.00	\$57.76
6	55	\$31.53	\$13.00	\$16.58	\$0.00	\$61.11
7	60	\$34.39	\$13.00	\$17.04	\$0.00	\$64.43
8	65	\$37.26	\$13.00	\$17.52	\$0.00	\$67.78
9	70	\$40.12	\$13.00	\$17.98	\$0.00	\$71.10
10	75	\$42.99	\$13.00	\$18.46	\$0.00	\$74.45

**Notes :**

App Prior 1/1/03; 30/35/40/45/50/55/65/70/75/80

**Apprentice to Journeyworker Ratio:2:3\*\*\***

ELEVATOR CONSTRUCTOR	01/01/2022	\$65.62	\$16.03	\$20.21	\$0.00	\$101.86
ELEVATOR CONSTRUCTORS LOCAL 4						

**Apprentice - ELEVATOR CONSTRUCTOR - Local 4**

**Effective Date - 01/01/2022**

Step	percent	Apprentice Base Wage	Health	Pension	Supplemental Unemployment	Total Rate
1	50	\$32.81	\$16.03	\$0.00	\$0.00	\$48.84
2	55	\$36.09	\$16.03	\$20.21	\$0.00	\$72.33
3	65	\$42.65	\$16.03	\$20.21	\$0.00	\$78.89
4	70	\$45.93	\$16.03	\$20.21	\$0.00	\$82.17
5	80	\$52.50	\$16.03	\$20.21	\$0.00	\$88.74

**Notes:**

Steps 1-2 are 6 mos.; Steps 3-5 are 1 year

**Apprentice to Journeyworker Ratio:1:1**

ELEVATOR CONSTRUCTOR HELPER <i>ELEVATOR CONSTRUCTORS LOCAL 4</i>	01/01/2022	\$45.93	\$16.03	\$20.21	\$0.00	\$82.17
---	------------	---------	---------	---------	--------	---------

For apprentice rates see "Apprentice - ELEVATOR CONSTRUCTOR"

FENCE & GUARD RAIL ERECTOR (HEAVY & HIGHWAY) <i>LABORERS - ZONE 1 (HEAVY &amp; HIGHWAY)</i>	12/01/2021	\$41.43	\$9.10	\$17.57	\$0.00	\$68.10
--	------------	---------	--------	---------	--------	---------

For apprentice rates see "Apprentice- LABORER (Heavy and Highway)"

FIELD ENG.INST.PERSON-BLDG,SITE,HVY/HWY <i>OPERATING ENGINEERS LOCAL 4</i>	11/01/2021	\$46.53	\$13.75	\$15.80	\$0.00	\$76.08
---	------------	---------	---------	---------	--------	---------

	05/01/2022	\$47.86	\$13.75	\$15.80	\$0.00	\$77.41
--	------------	---------	---------	---------	--------	---------

For apprentice rates see "Apprentice- OPERATING ENGINEERS"

FIELD ENG.PARTY CHIEF-BLDG,SITE,HVY/HWY <i>OPERATING ENGINEERS LOCAL 4</i>	11/01/2021	\$48.06	\$13.75	\$15.80	\$0.00	\$77.61
---	------------	---------	---------	---------	--------	---------

	05/01/2022	\$49.22	\$13.75	\$15.80	\$0.00	\$78.77
--	------------	---------	---------	---------	--------	---------

For apprentice rates see "Apprentice- OPERATING ENGINEERS"

FIELD ENG.ROD PERSON-BLDG,SITE,HVY/HWY <i>OPERATING ENGINEERS LOCAL 4</i>	11/01/2021	\$23.16	\$13.75	\$15.80	\$0.00	\$52.71
--	------------	---------	---------	---------	--------	---------

	05/01/2022	\$23.83	\$13.75	\$15.80	\$0.00	\$53.38
--	------------	---------	---------	---------	--------	---------

For apprentice rates see "Apprentice- OPERATING ENGINEERS"

FIRE ALARM INSTALLER <i>ELECTRICIANS LOCAL 103</i>	09/01/2021	\$56.36	\$13.00	\$20.54	\$0.00	\$89.90
---	------------	---------	---------	---------	--------	---------

	03/01/2022	\$57.32	\$13.00	\$20.82	\$0.00	\$91.14
--	------------	---------	---------	---------	--------	---------

	09/01/2022	\$58.76	\$13.00	\$20.86	\$0.00	\$92.62
--	------------	---------	---------	---------	--------	---------

	03/01/2023	\$60.43	\$13.00	\$20.91	\$0.00	\$94.34
--	------------	---------	---------	---------	--------	---------

For apprentice rates see "Apprentice- ELECTRICIAN"

FIRE ALARM REPAIR / MAINTENANCE <i>LOCAL 103</i>	09/01/2021	\$43.40	\$13.00	\$18.37	\$0.00	\$74.77
---	------------	---------	---------	---------	--------	---------

/ COMMISSIONING <i>ELECTRICIANS</i>	03/01/2022	\$44.71	\$13.00	\$18.74	\$0.00	\$76.45
-------------------------------------	------------	---------	---------	---------	--------	---------

	09/01/2022	\$46.42	\$13.00	\$18.87	\$0.00	\$78.29
--	------------	---------	---------	---------	--------	---------

	03/01/2023	\$48.34	\$13.00	\$19.01	\$0.00	\$80.35
--	------------	---------	---------	---------	--------	---------

For apprentice rates see "Apprentice- TELECOMMUNICATIONS TECHNICIAN"

FIREMAN (ASST. ENGINEER) <i>OPERATING ENGINEERS LOCAL 4</i>	12/01/2021	\$41.76	\$14.00	\$16.05	\$0.00	\$71.81
--	------------	---------	---------	---------	--------	---------

For apprentice rates see "Apprentice- OPERATING ENGINEERS"

FLAGGER & SIGNALER (HEAVY & HIGHWAY) <i>LABORERS - ZONE 1 (HEAVY &amp; HIGHWAY)</i>	12/01/2021	\$24.50	\$9.10	\$17.57	\$0.00	\$51.17
--	------------	---------	--------	---------	--------	---------

For apprentice rates see "Apprentice- LABORER (Heavy and Highway)"

FLOORCOVERER <i>FLOORCOVERERS LOCAL 2168 ZONE 1</i>	09/01/2021	\$49.38	\$8.58	\$20.12	\$0.00	\$78.08
--	------------	---------	--------	---------	--------	---------

	03/01/2022	\$50.18	\$8.58	\$20.12	\$0.00	\$78.88
--	------------	---------	--------	---------	--------	---------

**Classification**

**Effective Date   Base Wage   Health   Pension   Supplemental Unemployment   Total Rate**

**Apprentice - FLOORCOVERER - Local 2168 Zone I**

**Effective Date - 09/01/2021**

Step	percent	Apprentice Base Wage	Health	Pension	Supplemental Unemployment	Total Rate
1	50	\$24.69	\$8.58	\$1.79	\$0.00	\$35.06
2	55	\$27.16	\$8.58	\$1.79	\$0.00	\$37.53
3	60	\$29.63	\$8.58	\$14.75	\$0.00	\$52.96
4	65	\$32.10	\$8.58	\$14.75	\$0.00	\$55.43
5	70	\$34.57	\$8.58	\$16.54	\$0.00	\$59.69
6	75	\$37.04	\$8.58	\$16.54	\$0.00	\$62.16
7	80	\$39.50	\$8.58	\$18.33	\$0.00	\$66.41
8	85	\$41.97	\$8.58	\$18.33	\$0.00	\$68.88

**Effective Date - 03/01/2022**

Step	percent	Apprentice Base Wage	Health	Pension	Supplemental Unemployment	Total Rate
1	50	\$25.09	\$8.58	\$1.79	\$0.00	\$35.46
2	55	\$27.60	\$8.58	\$1.79	\$0.00	\$37.97
3	60	\$30.11	\$8.58	\$14.75	\$0.00	\$53.44
4	65	\$32.62	\$8.58	\$14.75	\$0.00	\$55.95
5	70	\$35.13	\$8.58	\$16.54	\$0.00	\$60.25
6	75	\$37.64	\$8.58	\$16.54	\$0.00	\$62.76
7	80	\$40.14	\$8.58	\$18.33	\$0.00	\$67.05
8	85	\$42.65	\$8.58	\$18.33	\$0.00	\$69.56

**Notes:** Steps are 750 hrs.  
 % After 10/1/17; 45/45/55/55/70/70/80/80 (1500hr Steps)  
 Step 1&2 \$32.59/ 3&4 \$39.26/ 5&6 \$59.69/ 7&8 \$66.41

**Apprentice to Journeyworker Ratio:1:1**

<b>FORK LIFT/CHERRY PICKER</b> <i>OPERATING ENGINEERS LOCAL 4</i>	12/01/2021	\$51.38	\$14.00	\$16.05	\$0.00	\$81.43
For apprentice rates see "Apprentice- OPERATING ENGINEERS"						
<b>GENERATOR/LIGHTING PLANT/HEATERS</b> <i>OPERATING ENGINEERS LOCAL 4</i>	12/01/2021	\$33.69	\$14.00	\$16.05	\$0.00	\$63.74
For apprentice rates see "Apprentice- OPERATING ENGINEERS"						
<b>GLAZIER (GLASS PLANK/AIR BARRIER/INTERIOR SYSTEMS)</b> <i>GLAZIERS LOCAL 35 (ZONE 1)</i>	01/01/2022	\$48.95	\$8.65	\$23.05	\$0.00	\$80.65
	07/01/2022	\$50.15	\$8.65	\$23.05	\$0.00	\$81.85
	01/01/2023	\$51.35	\$8.65	\$23.05	\$0.00	\$83.05
	07/01/2023	\$52.55	\$8.65	\$23.05	\$0.00	\$84.25
	01/01/2024	\$53.75	\$8.65	\$23.05	\$0.00	\$85.45
	07/01/2024	\$54.95	\$8.65	\$23.05	\$0.00	\$86.65
	01/01/2025	\$56.15	\$8.65	\$23.05	\$0.00	\$87.85

**Classification**

**Effective Date    Base Wage    Health    Pension    Supplemental Unemployment    Total Rate**

**Apprentice - GLAZIER - Local 35 Zone 1**

**Effective Date - 01/01/2022**

Step	percent	Apprentice Base Wage	Health	Pension	Supplemental Unemployment	Total Rate
1	50	\$24.48	\$8.65	\$0.00	\$0.00	\$33.13
2	55	\$26.92	\$8.65	\$6.27	\$0.00	\$41.84
3	60	\$29.37	\$8.65	\$6.84	\$0.00	\$44.86
4	65	\$31.82	\$8.65	\$7.41	\$0.00	\$47.88
5	70	\$34.27	\$8.65	\$19.63	\$0.00	\$62.55
6	75	\$36.71	\$8.65	\$20.20	\$0.00	\$65.56
7	80	\$39.16	\$8.65	\$20.77	\$0.00	\$68.58
8	90	\$44.06	\$8.65	\$21.91	\$0.00	\$74.62

**Effective Date - 07/01/2022**

Step	percent	Apprentice Base Wage	Health	Pension	Supplemental Unemployment	Total Rate
1	50	\$25.08	\$8.65	\$0.00	\$0.00	\$33.73
2	55	\$27.58	\$8.65	\$6.27	\$0.00	\$42.50
3	60	\$30.09	\$8.65	\$6.84	\$0.00	\$45.58
4	65	\$32.60	\$8.65	\$7.41	\$0.00	\$48.66
5	70	\$35.11	\$8.65	\$19.63	\$0.00	\$63.39
6	75	\$37.61	\$8.65	\$20.20	\$0.00	\$66.46
7	80	\$40.12	\$8.65	\$20.77	\$0.00	\$69.54
8	90	\$45.14	\$8.65	\$21.91	\$0.00	\$75.70

**Notes:**

Steps are 750 hrs.

**Apprentice to Journeyworker Ratio:1:1**

HOISTING ENGINEER/CRANES/GRADALLS OPERATING ENGINEERS LOCAL 4	12/01/2021	\$51.38	\$14.00	\$16.05	\$0.00	\$81.43
--	------------	---------	---------	---------	--------	---------

**Apprentice - OPERATING ENGINEERS - Local 4**

**Effective Date - 12/01/2021**

Step	percent	Apprentice Base Wage	Health	Pension	Supplemental Unemployment	Total Rate
1	55	\$28.26	\$14.00	\$0.00	\$0.00	\$42.26
2	60	\$30.83	\$14.00	\$16.05	\$0.00	\$60.88
3	65	\$33.40	\$14.00	\$16.05	\$0.00	\$63.45
4	70	\$35.97	\$14.00	\$16.05	\$0.00	\$66.02
5	75	\$38.54	\$14.00	\$16.05	\$0.00	\$68.59
6	80	\$41.10	\$14.00	\$16.05	\$0.00	\$71.15
7	85	\$43.67	\$14.00	\$16.05	\$0.00	\$73.72
8	90	\$46.24	\$14.00	\$16.05	\$0.00	\$76.29

**Notes:**

**Apprentice to Journeyworker Ratio:1:6**

HVAC (DUCTWORK) <i>SHEETMETAL WORKERS LOCAL 17 - A</i>	08/01/2021	\$51.95	\$13.80	\$25.60	\$2.74	\$94.09
	02/01/2022	\$53.70	\$13.80	\$25.60	\$2.79	\$95.89
For apprentice rates see "Apprentice- SHEET METAL WORKER"						
HVAC (ELECTRICAL CONTROLS) <i>ELECTRICIANS LOCAL 103</i>	09/01/2021	\$56.36	\$13.00	\$20.54	\$0.00	\$89.90
	03/01/2022	\$57.32	\$13.00	\$20.82	\$0.00	\$91.14
	09/01/2022	\$58.76	\$13.00	\$20.86	\$0.00	\$92.62
	03/01/2023	\$60.43	\$13.00	\$20.91	\$0.00	\$94.34
For apprentice rates see "Apprentice- ELECTRICIAN"						
HVAC (TESTING AND BALANCING - AIR) <i>SHEETMETAL WORKERS LOCAL 17 - A</i>	08/01/2021	\$51.95	\$13.80	\$25.60	\$2.74	\$94.09
	02/01/2022	\$53.70	\$13.80	\$25.60	\$2.79	\$95.89
For apprentice rates see "Apprentice- SHEET METAL WORKER"						
HVAC (TESTING AND BALANCING - WATER) <i>PIPEFITTERS LOCAL 537</i>	03/01/2021	\$57.94	\$11.70	\$20.24	\$0.00	\$89.88
For apprentice rates see "Apprentice- PIPEFITTER" or "PLUMBER/PIPEFITTER"						
HVAC MECHANIC <i>PIPEFITTERS LOCAL 537</i>	03/01/2021	\$57.94	\$11.70	\$20.24	\$0.00	\$89.88
For apprentice rates see "Apprentice- PIPEFITTER" or "PLUMBER/PIPEFITTER"						
HYDRAULIC DRILLS <i>LABORERS - ZONE 1</i>	12/01/2021	\$41.93	\$9.10	\$17.57	\$0.00	\$68.60
	06/01/2022	\$42.93	\$9.10	\$17.57	\$0.00	\$69.60
	12/01/2022	\$43.93	\$9.10	\$17.57	\$0.00	\$70.60
	06/01/2023	\$44.93	\$9.10	\$17.57	\$0.00	\$71.60
	12/01/2023	\$46.18	\$9.10	\$17.57	\$0.00	\$72.85
For apprentice rates see "Apprentice- LABORER"						
HYDRAULIC DRILLS (HEAVY & HIGHWAY) <i>LABORERS - ZONE 1 (HEAVY &amp; HIGHWAY)</i>	12/01/2021	\$41.93	\$9.10	\$17.57	\$0.00	\$68.60
For apprentice rates see "Apprentice- LABORER (Heavy and Highway)"						
INSULATOR (PIPES & TANKS) <i>HEAT &amp; FROST INSULATORS LOCAL 6 (BOSTON)</i>	09/01/2021	\$51.40	\$13.80	\$17.14	\$0.00	\$82.34
	09/01/2022	\$53.85	\$13.80	\$17.14	\$0.00	\$84.79

**Classification**

**Effective Date    Base Wage    Health    Pension    Supplemental Unemployment    Total Rate**

**Apprentice - ASBESTOS INSULATOR (Pipes & Tanks) - Local 6 Boston**

**Effective Date - 09/01/2021**

Step	percent	Apprentice Base Wage	Health	Pension	Supplemental Unemployment	Total Rate
1	50	\$25.70	\$13.80	\$12.42	\$0.00	\$51.92
2	60	\$30.84	\$13.80	\$13.36	\$0.00	\$58.00
3	70	\$35.98	\$13.80	\$14.31	\$0.00	\$64.09
4	80	\$41.12	\$13.80	\$15.25	\$0.00	\$70.17

**Effective Date - 09/01/2022**

Step	percent	Apprentice Base Wage	Health	Pension	Supplemental Unemployment	Total Rate
1	50	\$26.93	\$13.80	\$12.42	\$0.00	\$53.15
2	60	\$32.31	\$13.80	\$13.36	\$0.00	\$59.47
3	70	\$37.70	\$13.80	\$14.31	\$0.00	\$65.81
4	80	\$43.08	\$13.80	\$15.25	\$0.00	\$72.13

**Notes:**

Steps are 1 year

**Apprentice to Journeyworker Ratio:1:4**

<b>IRONWORKER/WELDER</b> <i>IRONWORKERS LOCAL 7 (BOSTON AREA)</i>	09/16/2020	\$48.66	\$8.10	\$25.10	\$0.00	\$81.86
--	------------	---------	--------	---------	--------	---------

**Apprentice - IRONWORKER - Local 7 Boston**

**Effective Date - 09/16/2020**

Step	percent	Apprentice Base Wage	Health	Pension	Supplemental Unemployment	Total Rate
1	60	\$29.20	\$8.10	\$25.10	\$0.00	\$62.40
2	70	\$34.06	\$8.10	\$25.10	\$0.00	\$67.26
3	75	\$36.50	\$8.10	\$25.10	\$0.00	\$69.70
4	80	\$38.93	\$8.10	\$25.10	\$0.00	\$72.13
5	85	\$41.36	\$8.10	\$25.10	\$0.00	\$74.56
6	90	\$43.79	\$8.10	\$25.10	\$0.00	\$76.99

**Notes:**

\*\* Structural 1:6; Ornamental 1:4

**Apprentice to Journeyworker Ratio:\*\***

<b>JACKHAMMER &amp; PAVING BREAKER OPERATOR</b> <i>LABORERS - ZONE 1</i>	12/01/2021	\$41.43	\$9.10	\$17.57	\$0.00	\$68.10
	06/01/2022	\$42.43	\$9.10	\$17.57	\$0.00	\$69.10
	12/01/2022	\$43.43	\$9.10	\$17.57	\$0.00	\$70.10
	06/01/2023	\$44.43	\$9.10	\$17.57	\$0.00	\$71.10
	12/01/2023	\$45.68	\$9.10	\$17.57	\$0.00	\$72.35

For apprentice rates see "Apprentice- LABORER"



Classification	Effective Date	Base Wage	Health	Pension	Supplemental Unemployment	Total Rate
LABORER LABORERS - ZONE 1	12/01/2021	\$41.18	\$9.10	\$17.57	\$0.00	\$67.85
	06/01/2022	\$42.18	\$9.10	\$17.57	\$0.00	\$68.85
	12/01/2022	\$43.18	\$9.10	\$17.57	\$0.00	\$69.85
	06/01/2023	\$44.18	\$9.10	\$17.57	\$0.00	\$70.85
	12/01/2023	\$45.43	\$9.10	\$17.57	\$0.00	\$72.10

**Apprentice - LABORER - Zone 1**

**Effective Date - 12/01/2021**

Step	percent	Apprentice Base Wage	Health	Pension	Supplemental Unemployment	Total Rate
1	60	\$24.71	\$9.10	\$17.57	\$0.00	\$51.38
2	70	\$28.83	\$9.10	\$17.57	\$0.00	\$55.50
3	80	\$32.94	\$9.10	\$17.57	\$0.00	\$59.61
4	90	\$37.06	\$9.10	\$17.57	\$0.00	\$63.73

**Effective Date - 06/01/2022**

Step	percent	Apprentice Base Wage	Health	Pension	Supplemental Unemployment	Total Rate
1	60	\$25.31	\$9.10	\$17.57	\$0.00	\$51.98
2	70	\$29.53	\$9.10	\$17.57	\$0.00	\$56.20
3	80	\$33.74	\$9.10	\$17.57	\$0.00	\$60.41
4	90	\$37.96	\$9.10	\$17.57	\$0.00	\$64.63

Notes:

**Apprentice to Journeyworker Ratio:1:5**

LABORER (HEAVY & HIGHWAY) LABORERS - ZONE 1 (HEAVY & HIGHWAY)	12/01/2021	\$41.18	\$9.10	\$17.57	\$0.00	\$67.85
--	------------	---------	--------	---------	--------	---------

**Apprentice - LABORER (Heavy & Highway) - Zone 1**

**Effective Date - 12/01/2021**

Step	percent	Apprentice Base Wage	Health	Pension	Supplemental Unemployment	Total Rate
1	60	\$24.71	\$9.10	\$17.57	\$0.00	\$51.38
2	70	\$28.83	\$9.10	\$17.57	\$0.00	\$55.50
3	80	\$32.94	\$9.10	\$17.57	\$0.00	\$59.61
4	90	\$37.06	\$9.10	\$17.57	\$0.00	\$63.73

Notes:

**Apprentice to Journeyworker Ratio:1:5**

LABORER: CARPENTER TENDER LABORERS - ZONE 1	12/01/2021	\$41.18	\$9.10	\$17.57	\$0.00	\$67.85
	06/01/2022	\$42.18	\$9.10	\$17.57	\$0.00	\$68.85
	12/01/2022	\$43.18	\$9.10	\$17.57	\$0.00	\$69.85
	06/01/2023	\$44.18	\$9.10	\$17.57	\$0.00	\$70.85
	12/01/2023	\$45.43	\$9.10	\$17.57	\$0.00	\$72.10

For apprentice rates see "Apprentice- LABORER"

Classification	Effective Date	Base Wage	Health	Pension	Supplemental Unemployment	Total Rate
LABORER: CEMENT FINISHER TENDER <i>LABORERS - ZONE 1</i>	12/01/2021	\$41.18	\$9.10	\$17.57	\$0.00	\$67.85
	06/01/2022	\$42.18	\$9.10	\$17.57	\$0.00	\$68.85
	12/01/2022	\$43.18	\$9.10	\$17.57	\$0.00	\$69.85
	06/01/2023	\$44.18	\$9.10	\$17.57	\$0.00	\$70.85
	12/01/2023	\$45.43	\$9.10	\$17.57	\$0.00	\$72.10
For apprentice rates see "Apprentice- LABORER"						
LABORER: HAZARDOUS WASTE/ASBESTOS REMOVER <i>LABORERS - ZONE 1</i>	12/01/2021	\$41.33	\$9.10	\$17.57	\$0.00	\$68.00
	06/01/2022	\$42.33	\$9.10	\$17.57	\$0.00	\$69.00
	12/01/2022	\$43.33	\$9.10	\$17.57	\$0.00	\$70.00
	06/01/2023	\$44.33	\$9.10	\$17.57	\$0.00	\$71.00
	12/01/2023	\$45.58	\$9.10	\$17.57	\$0.00	\$72.25
For apprentice rates see "Apprentice- LABORER"						
LABORER: MASON TENDER <i>LABORERS - ZONE 1</i>	12/01/2021	\$41.43	\$9.10	\$17.57	\$0.00	\$68.10
	06/01/2022	\$42.43	\$9.10	\$17.57	\$0.00	\$69.10
	12/01/2022	\$43.43	\$9.10	\$17.57	\$0.00	\$70.10
	06/01/2023	\$44.43	\$9.10	\$17.57	\$0.00	\$71.10
	06/01/2024	\$45.68	\$9.10	\$17.57	\$0.00	\$72.35
For apprentice rates see "Apprentice- LABORER"						
LABORER: MASON TENDER (HEAVY & HIGHWAY) <i>LABORERS - ZONE 1 (HEAVY &amp; HIGHWAY)</i>	12/01/2021	\$41.43	\$9.10	\$17.57	\$0.00	\$68.10
For apprentice rates see "Apprentice- LABORER (Heavy and Highway)"						
LABORER: MULTI-TRADE TENDER <i>LABORERS - ZONE 1</i>	12/01/2021	\$41.18	\$9.10	\$17.57	\$0.00	\$67.85
	06/01/2022	\$42.18	\$9.10	\$17.57	\$0.00	\$68.85
	12/01/2022	\$43.18	\$9.10	\$17.57	\$0.00	\$69.85
	06/01/2023	\$44.18	\$9.10	\$17.57	\$0.00	\$70.85
	12/01/2023	\$45.43	\$9.10	\$17.57	\$0.00	\$72.10
For apprentice rates see "Apprentice- LABORER"						
LABORER: TREE REMOVER <i>LABORERS - ZONE 1</i>	12/01/2021	\$41.18	\$9.10	\$17.57	\$0.00	\$67.85
	06/01/2022	\$42.18	\$9.10	\$17.57	\$0.00	\$68.85
	12/01/2022	\$43.18	\$9.10	\$17.57	\$0.00	\$69.85
	06/01/2023	\$44.18	\$9.10	\$17.57	\$0.00	\$70.85
	12/01/2023	\$45.43	\$9.10	\$17.57	\$0.00	\$72.10
This classification applies to the removal of standing trees, and the trimming and removal of branches and limbs when related to public works construction or site clearance incidental to construction . For apprentice rates see "Apprentice- LABORER"						
LASER BEAM OPERATOR <i>LABORERS - ZONE 1</i>	12/01/2021	\$41.43	\$9.10	\$17.57	\$0.00	\$68.10
	06/01/2022	\$42.43	\$9.10	\$17.57	\$0.00	\$69.10
	12/01/2022	\$43.43	\$9.10	\$17.57	\$0.00	\$70.10
	06/01/2023	\$44.43	\$9.10	\$17.57	\$0.00	\$71.10
	12/01/2023	\$45.68	\$9.10	\$17.57	\$0.00	\$72.35
For apprentice rates see "Apprentice- LABORER"						
LASER BEAM OPERATOR (HEAVY & HIGHWAY) <i>LABORERS - ZONE 1 (HEAVY &amp; HIGHWAY)</i>	12/01/2021	\$41.43	\$9.10	\$17.57	\$0.00	\$68.10
For apprentice rates see "Apprentice- LABORER (Heavy and Highway)"						
MARBLE & TILE FINISHERS <i>BRICKLAYERS LOCAL 3 - MARBLE &amp; TILE</i>	08/01/2021	\$43.69	\$11.39	\$20.30	\$0.00	\$75.38
	02/01/2022	\$43.69	\$11.39	\$20.37	\$0.00	\$75.45

**Classification**

**Effective Date   Base Wage   Health   Pension   Supplemental Unemployment   Total Rate**

**Apprentice - MARBLE & TILE FINISHER - Local 3 Marble & Tile**

**Effective Date - 08/01/2021**

Step	percent	Apprentice Base Wage	Health	Pension	Supplemental Unemployment	Total Rate
1	50	\$21.85	\$11.39	\$20.30	\$0.00	\$53.54
2	60	\$26.21	\$11.39	\$20.30	\$0.00	\$57.90
3	70	\$30.58	\$11.39	\$20.30	\$0.00	\$62.27
4	80	\$34.95	\$11.39	\$20.30	\$0.00	\$66.64
5	90	\$39.32	\$11.39	\$20.30	\$0.00	\$71.01

**Effective Date - 02/01/2022**

Step	percent	Apprentice Base Wage	Health	Pension	Supplemental Unemployment	Total Rate
1	50	\$21.85	\$11.39	\$20.37	\$0.00	\$53.61
2	60	\$26.21	\$11.39	\$20.37	\$0.00	\$57.97
3	70	\$30.58	\$11.39	\$20.37	\$0.00	\$62.34
4	80	\$34.95	\$11.39	\$20.37	\$0.00	\$66.71
5	90	\$39.32	\$11.39	\$20.37	\$0.00	\$71.08

**Notes:**

**Apprentice to Journeyworker Ratio:1:3**

MARBLE MASONS, TILELAYERS & TERRAZZO MECH	08/01/2021	\$57.17	\$11.39	\$22.24	\$0.00	\$90.80
BRICKLAYERS LOCAL 3 - MARBLE & TILE	02/01/2022	\$57.17	\$11.39	\$22.31	\$0.00	\$90.87

**Apprentice - MARBLE-TILE-TERRAZZO MECHANIC - Local 3 Marble & Tile**

**Effective Date - 08/01/2021**

Step	percent	Apprentice Base Wage	Health	Pension	Supplemental Unemployment	Total Rate
1	50	\$28.59	\$11.39	\$22.24	\$0.00	\$62.22
2	60	\$34.30	\$11.39	\$22.24	\$0.00	\$67.93
3	70	\$40.02	\$11.39	\$22.24	\$0.00	\$73.65
4	80	\$45.74	\$11.39	\$22.24	\$0.00	\$79.37
5	90	\$51.45	\$11.39	\$22.24	\$0.00	\$85.08

**Effective Date - 02/01/2022**

Step	percent	Apprentice Base Wage	Health	Pension	Supplemental Unemployment	Total Rate
1	50	\$28.59	\$11.39	\$22.31	\$0.00	\$62.29
2	60	\$34.30	\$11.39	\$22.31	\$0.00	\$68.00
3	70	\$40.02	\$11.39	\$22.31	\$0.00	\$73.72
4	80	\$45.74	\$11.39	\$22.31	\$0.00	\$79.44
5	90	\$51.45	\$11.39	\$22.31	\$0.00	\$85.15

**Notes:**

**Apprentice to Journeyworker Ratio:1:5**

Classification	Effective Date	Base Wage	Health	Pension	Supplemental Unemployment	Total Rate
MECH. SWEEPER OPERATOR (ON CONST. SITES) <i>OPERATING ENGINEERS LOCAL 4</i>	12/01/2021	\$50.83	\$14.00	\$16.05	\$0.00	\$80.88
For apprentice rates see "Apprentice- OPERATING ENGINEERS"						
MECHANICS MAINTENANCE <i>OPERATING ENGINEERS LOCAL 4</i>	12/01/2021	\$50.83	\$14.00	\$16.05	\$0.00	\$80.88
For apprentice rates see "Apprentice- OPERATING ENGINEERS"						
MILLWRIGHT (Zone 1) <i>MILLWRIGHTS LOCAL 1121 - Zone 1</i>	01/03/2022	\$45.52	\$8.58	\$21.57	\$0.00	\$75.67
	01/02/2023	\$47.27	\$8.58	\$21.57	\$0.00	\$77.42

**Apprentice - MILLWRIGHT - Local 1121 Zone 1**

**Effective Date - 01/03/2022**

Step	percent	Apprentice Base Wage	Health	Pension	Supplemental Unemployment	Total Rate
1	55	\$25.04	\$8.58	\$5.72	\$0.00	\$39.34
2	65	\$29.59	\$8.58	\$17.93	\$0.00	\$56.10
3	75	\$34.14	\$8.58	\$18.98	\$0.00	\$61.70
4	85	\$38.69	\$8.58	\$20.01	\$0.00	\$67.28

**Effective Date - 01/02/2023**

Step	percent	Apprentice Base Wage	Health	Pension	Supplemental Unemployment	Total Rate
1	55	\$26.00	\$8.58	\$5.72	\$0.00	\$40.30
2	65	\$30.73	\$8.58	\$17.93	\$0.00	\$57.24
3	75	\$35.45	\$8.58	\$18.98	\$0.00	\$63.01
4	85	\$40.18	\$8.58	\$20.01	\$0.00	\$68.77

**Notes:** Step 1&2 Appr. indentured after 1/6/2020 receive no pension, but do receive annuity. (Step 1 \$5.72, Step 2 \$6.66)  
Steps are 2,000 hours

**Apprentice to Journeyworker Ratio:1:4**

MORTAR MIXER <i>LABORERS - ZONE 1</i>	12/01/2021	\$41.43	\$9.10	\$17.57	\$0.00	\$68.10
	06/01/2022	\$42.43	\$9.10	\$17.57	\$0.00	\$69.10
	12/01/2022	\$43.43	\$9.10	\$17.57	\$0.00	\$70.10
	06/01/2023	\$44.43	\$9.10	\$17.57	\$0.00	\$71.10
	12/01/2023	\$45.68	\$9.10	\$17.57	\$0.00	\$72.35

For apprentice rates see "Apprentice- LABORER"

OILER (OTHER THAN TRUCK CRANES, GRADALLS) <i>OPERATING ENGINEERS LOCAL 4</i>	12/01/2021	\$23.48	\$14.00	\$16.05	\$0.00	\$53.53
---	------------	---------	---------	---------	--------	---------

For apprentice rates see "Apprentice- OPERATING ENGINEERS"

OILER (TRUCK CRANES, GRADALLS) <i>OPERATING ENGINEERS LOCAL 4</i>	12/01/2021	\$28.44	\$14.00	\$16.05	\$0.00	\$58.49
--	------------	---------	---------	---------	--------	---------

For apprentice rates see "Apprentice- OPERATING ENGINEERS"

OTHER POWER DRIVEN EQUIPMENT - CLASS II <i>OPERATING ENGINEERS LOCAL 4</i>	12/01/2021	\$50.83	\$14.00	\$16.05	\$0.00	\$80.88
---	------------	---------	---------	---------	--------	---------

For apprentice rates see "Apprentice- OPERATING ENGINEERS"

Classification	Effective Date	Base Wage	Health	Pension	Supplemental Unemployment	Total Rate
PAINTER (BRIDGES/TANKS) <i>PAINTERS LOCAL 35 - ZONE 1</i>	01/01/2022	\$53.66	\$8.65	\$23.05	\$0.00	\$85.36
	07/01/2022	\$54.86	\$8.65	\$23.05	\$0.00	\$86.56
	01/01/2023	\$56.06	\$8.65	\$23.05	\$0.00	\$87.76
	07/01/2023	\$57.26	\$8.65	\$23.05	\$0.00	\$88.96
	01/01/2024	\$58.46	\$8.65	\$23.05	\$0.00	\$90.16
	07/01/2024	\$59.66	\$8.65	\$23.05	\$0.00	\$91.36
	01/01/2025	\$60.86	\$8.65	\$23.05	\$0.00	\$92.56

**Apprentice - PAINTER Local 35 - BRIDGES/TANKS**

**Effective Date - 01/01/2022**

Step	percent	Apprentice Base Wage	Health	Pension	Supplemental Unemployment	Total Rate
1	50	\$26.83	\$8.65	\$0.00	\$0.00	\$35.48
2	55	\$29.51	\$8.65	\$6.27	\$0.00	\$44.43
3	60	\$32.20	\$8.65	\$6.84	\$0.00	\$47.69
4	65	\$34.88	\$8.65	\$7.41	\$0.00	\$50.94
5	70	\$37.56	\$8.65	\$19.63	\$0.00	\$65.84
6	75	\$40.25	\$8.65	\$20.20	\$0.00	\$69.10
7	80	\$42.93	\$8.65	\$20.77	\$0.00	\$72.35
8	90	\$48.29	\$8.65	\$21.91	\$0.00	\$78.85

**Effective Date - 07/01/2022**

Step	percent	Apprentice Base Wage	Health	Pension	Supplemental Unemployment	Total Rate
1	50	\$27.43	\$8.65	\$0.00	\$0.00	\$36.08
2	55	\$30.17	\$8.65	\$6.27	\$0.00	\$45.09
3	60	\$32.92	\$8.65	\$6.84	\$0.00	\$48.41
4	65	\$35.66	\$8.65	\$7.41	\$0.00	\$51.72
5	70	\$38.40	\$8.65	\$19.63	\$0.00	\$66.68
6	75	\$41.15	\$8.65	\$20.20	\$0.00	\$70.00
7	80	\$43.89	\$8.65	\$20.77	\$0.00	\$73.31
8	90	\$49.37	\$8.65	\$21.91	\$0.00	\$79.93

**Notes:**

Steps are 750 hrs.

**Apprentice to Journeyworker Ratio:1:1**

PAINTER (SPRAY OR SANDBLAST, NEW) *	01/01/2022	\$50.35	\$8.65	\$23.05	\$0.00	\$82.05
* If 30% or more of surfaces to be painted are new construction, NEW paint rate shall be used. <i>PAINTERS LOCAL 35 - ZONE 1</i>	07/01/2022	\$51.55	\$8.65	\$23.05	\$0.00	\$83.25
	01/01/2023	\$52.75	\$8.65	\$23.05	\$0.00	\$84.45
	07/01/2023	\$53.95	\$8.65	\$23.05	\$0.00	\$85.65
	01/01/2024	\$55.15	\$8.65	\$23.05	\$0.00	\$86.85
	07/01/2024	\$56.35	\$8.65	\$23.05	\$0.00	\$88.05
	01/01/2025	\$57.55	\$8.65	\$23.05	\$0.00	\$89.25

**Classification**

**Effective Date    Base Wage    Health    Pension    Supplemental Unemployment    Total Rate**

**Apprentice - PAINTER Local 35 Zone 1 - Spray/Sandblast - New**

**Effective Date - 01/01/2022**

Step	percent	Apprentice Base Wage	Health	Pension	Supplemental Unemployment	Total Rate
1	50	\$25.18	\$8.65	\$0.00	\$0.00	\$33.83
2	55	\$27.69	\$8.65	\$6.27	\$0.00	\$42.61
3	60	\$30.21	\$8.65	\$6.84	\$0.00	\$45.70
4	65	\$32.73	\$8.65	\$7.41	\$0.00	\$48.79
5	70	\$35.25	\$8.65	\$19.63	\$0.00	\$63.53
6	75	\$37.76	\$8.65	\$20.20	\$0.00	\$66.61
7	80	\$40.28	\$8.65	\$20.77	\$0.00	\$69.70
8	90	\$45.32	\$8.65	\$21.91	\$0.00	\$75.88

**Effective Date - 07/01/2022**

Step	percent	Apprentice Base Wage	Health	Pension	Supplemental Unemployment	Total Rate
1	50	\$25.78	\$8.65	\$0.00	\$0.00	\$34.43
2	55	\$28.35	\$8.65	\$6.27	\$0.00	\$43.27
3	60	\$30.93	\$8.65	\$6.84	\$0.00	\$46.42
4	65	\$33.51	\$8.65	\$7.41	\$0.00	\$49.57
5	70	\$36.09	\$8.65	\$19.63	\$0.00	\$64.37
6	75	\$38.66	\$8.65	\$20.20	\$0.00	\$67.51
7	80	\$41.24	\$8.65	\$20.77	\$0.00	\$70.66
8	90	\$46.40	\$8.65	\$21.91	\$0.00	\$76.96

**Notes:**

Steps are 750 hrs.

**Apprentice to Journeyworker Ratio:1:1**

PAINTER (SPRAY OR SANDBLAST, REPAINT)	01/01/2022	\$48.41	\$8.65	\$23.05	\$0.00	\$80.11
PAINTERS LOCAL 35 - ZONE 1	07/01/2022	\$49.61	\$8.65	\$23.05	\$0.00	\$81.31
	01/01/2023	\$50.81	\$8.65	\$23.05	\$0.00	\$82.51
	07/01/2023	\$52.01	\$8.65	\$23.05	\$0.00	\$83.71
	01/01/2024	\$53.21	\$8.65	\$23.05	\$0.00	\$84.91
	01/01/2025	\$55.61	\$8.65	\$23.05	\$0.00	\$87.31
	07/01/2025	\$54.41	\$8.65	\$23.05	\$0.00	\$86.11

**Classification**

**Effective Date    Base Wage    Health    Pension    Supplemental Unemployment    Total Rate**

**Apprentice - PAINTER Local 35 Zone 1 - Spray/Sandblast - Repaint**

**Effective Date - 01/01/2022**

Step	percent	Apprentice Base Wage	Health	Pension	Supplemental Unemployment	Total Rate
1	50	\$24.21	\$8.65	\$0.00	\$0.00	\$32.86
2	55	\$26.63	\$8.65	\$6.27	\$0.00	\$41.55
3	60	\$29.05	\$8.65	\$6.84	\$0.00	\$44.54
4	65	\$31.47	\$8.65	\$7.41	\$0.00	\$47.53
5	70	\$33.89	\$8.65	\$19.63	\$0.00	\$62.17
6	75	\$36.31	\$8.65	\$20.20	\$0.00	\$65.16
7	80	\$38.73	\$8.65	\$20.77	\$0.00	\$68.15
8	90	\$43.57	\$8.65	\$21.91	\$0.00	\$74.13

**Effective Date - 07/01/2022**

Step	percent	Apprentice Base Wage	Health	Pension	Supplemental Unemployment	Total Rate
1	50	\$24.81	\$8.65	\$0.00	\$0.00	\$33.46
2	55	\$27.29	\$8.65	\$6.27	\$0.00	\$42.21
3	60	\$29.77	\$8.65	\$6.84	\$0.00	\$45.26
4	65	\$32.25	\$8.65	\$7.41	\$0.00	\$48.31
5	70	\$34.73	\$8.65	\$19.63	\$0.00	\$63.01
6	75	\$37.21	\$8.65	\$20.20	\$0.00	\$66.06
7	80	\$39.69	\$8.65	\$20.77	\$0.00	\$69.11
8	90	\$44.65	\$8.65	\$21.91	\$0.00	\$75.21

**Notes:**

Steps are 750 hrs.

**Apprentice to Journeyworker Ratio:1:1**

PAINTER / TAPER (BRUSH, NEW) *	01/01/2022	\$48.95	\$8.65	\$23.05	\$0.00	\$80.65
* If 30% or more of surfaces to be painted are new construction, NEW paint rate shall be used. PAINTERS LOCAL 35 - ZONE 1	07/01/2022	\$50.15	\$8.65	\$23.05	\$0.00	\$81.85
	01/01/2023	\$51.35	\$8.65	\$23.05	\$0.00	\$83.05
	07/01/2023	\$52.55	\$8.65	\$23.05	\$0.00	\$84.25
	01/01/2024	\$53.75	\$8.65	\$23.05	\$0.00	\$85.45
	07/01/2024	\$54.95	\$8.65	\$23.05	\$0.00	\$86.65
	01/01/2025	\$56.15	\$8.65	\$23.05	\$0.00	\$87.85

**Apprentice - PAINTER - Local 35 Zone 1 - BRUSH NEW**

**Effective Date - 01/01/2022**

Step	percent	Apprentice Base Wage	Health	Pension	Supplemental Unemployment	Total Rate
1	50	\$24.48	\$8.65	\$0.00	\$0.00	\$33.13
2	55	\$26.92	\$8.65	\$6.27	\$0.00	\$41.84
3	60	\$29.37	\$8.65	\$6.84	\$0.00	\$44.86
4	65	\$31.82	\$8.65	\$7.41	\$0.00	\$47.88
5	70	\$34.27	\$8.65	\$19.63	\$0.00	\$62.55
6	75	\$36.71	\$8.65	\$20.20	\$0.00	\$65.56
7	80	\$39.16	\$8.65	\$20.77	\$0.00	\$68.58
8	90	\$44.06	\$8.65	\$21.91	\$0.00	\$74.62

**Effective Date - 07/01/2022**

Step	percent	Apprentice Base Wage	Health	Pension	Supplemental Unemployment	Total Rate
1	50	\$25.08	\$8.65	\$0.00	\$0.00	\$33.73
2	55	\$27.58	\$8.65	\$6.27	\$0.00	\$42.50
3	60	\$30.09	\$8.65	\$6.84	\$0.00	\$45.58
4	65	\$32.60	\$8.65	\$7.41	\$0.00	\$48.66
5	70	\$35.11	\$8.65	\$19.63	\$0.00	\$63.39
6	75	\$37.61	\$8.65	\$20.20	\$0.00	\$66.46
7	80	\$40.12	\$8.65	\$20.77	\$0.00	\$69.54
8	90	\$45.14	\$8.65	\$21.91	\$0.00	\$75.70

**Notes:**  
Steps are 750 hrs.

**Apprentice to Journeyworker Ratio:1:1**

PAINTER / TAPER (BRUSH, REPAINT)	01/01/2022	\$47.01	\$8.65	\$23.05	\$0.00	\$78.71
PAINTERS LOCAL 35 - ZONE 1	07/01/2022	\$48.21	\$8.65	\$23.05	\$0.00	\$79.91
	01/01/2023	\$49.41	\$8.65	\$23.05	\$0.00	\$81.11
	07/01/2023	\$50.61	\$8.65	\$23.05	\$0.00	\$82.31
	01/01/2024	\$51.81	\$8.65	\$23.05	\$0.00	\$83.51
	07/01/2024	\$53.01	\$8.65	\$23.05	\$0.00	\$84.71
	01/01/2025	\$54.21	\$8.65	\$23.05	\$0.00	\$85.91



**Classification**

**Effective Date   Base Wage   Health   Pension   Supplemental Unemployment   Total Rate**

**Apprentice - PAINTER Local 35 Zone 1 - BRUSH REPAINT**

**Effective Date - 01/01/2022**

Step	percent	Apprentice Base Wage	Health	Pension	Supplemental Unemployment	Total Rate
1	50	\$23.51	\$8.65	\$0.00	\$0.00	\$32.16
2	55	\$25.86	\$8.65	\$6.27	\$0.00	\$40.78
3	60	\$28.21	\$8.65	\$6.84	\$0.00	\$43.70
4	65	\$30.56	\$8.65	\$7.41	\$0.00	\$46.62
5	70	\$32.91	\$8.65	\$19.63	\$0.00	\$61.19
6	75	\$35.26	\$8.65	\$20.20	\$0.00	\$64.11
7	80	\$37.61	\$8.65	\$20.77	\$0.00	\$67.03
8	90	\$42.31	\$8.65	\$21.91	\$0.00	\$72.87

**Effective Date - 07/01/2022**

Step	percent	Apprentice Base Wage	Health	Pension	Supplemental Unemployment	Total Rate
1	50	\$24.11	\$8.65	\$0.00	\$0.00	\$32.76
2	55	\$26.52	\$8.65	\$6.27	\$0.00	\$41.44
3	60	\$28.93	\$8.65	\$6.84	\$0.00	\$44.42
4	65	\$31.34	\$8.65	\$7.41	\$0.00	\$47.40
5	70	\$33.75	\$8.65	\$19.63	\$0.00	\$62.03
6	75	\$36.16	\$8.65	\$20.20	\$0.00	\$65.01
7	80	\$38.57	\$8.65	\$20.77	\$0.00	\$67.99
8	90	\$43.39	\$8.65	\$21.91	\$0.00	\$73.95

**Notes:**

Steps are 750 hrs.

**Apprentice to Journeyworker Ratio:1:1**

PAINTER TRAFFIC MARKINGS (HEAVY/HIGHWAY) LABORERS - ZONE 1 (HEAVY & HIGHWAY)	12/01/2021	\$41.18	\$9.10	\$17.57	\$0.00	\$67.85
---	------------	---------	--------	---------	--------	---------

For apprentice rates see "Apprentice- LABORER (Heavy and Highway)

PANEL & PICKUP TRUCKS DRIVER TEAMSTERS JOINT COUNCIL NO. 10 ZONE A	12/01/2021	\$36.88	\$13.41	\$16.01	\$0.00	\$66.30
---	------------	---------	---------	---------	--------	---------

PIER AND DOCK CONSTRUCTOR (UNDERPINNING AND DECK) PILE DRIVER LOCAL 56 (ZONE 1)	08/01/2020	\$49.07	\$9.40	\$23.12	\$0.00	\$81.59
--	------------	---------	--------	---------	--------	---------

For apprentice rates see "Apprentice- PILE DRIVER"

PILE DRIVER PILE DRIVER LOCAL 56 (ZONE 1)	08/01/2020	\$49.07	\$9.40	\$23.12	\$0.00	\$81.59
--	------------	---------	--------	---------	--------	---------

**Classification**

**Effective Date    Base Wage    Health    Pension    Supplemental Unemployment    Total Rate**

**Apprentice - PILE DRIVER - Local 56 Zone 1**

**Effective Date - 08/01/2020**

Step	percent	Apprentice Base Wage	Health	Pension	Supplemental Unemployment	Total Rate
1	50	\$24.54	\$9.40	\$23.12	\$0.00	\$57.06
2	60	\$29.44	\$9.40	\$23.12	\$0.00	\$61.96
3	70	\$34.35	\$9.40	\$23.12	\$0.00	\$66.87
4	75	\$36.80	\$9.40	\$23.12	\$0.00	\$69.32
5	80	\$39.26	\$9.40	\$23.12	\$0.00	\$71.78
6	80	\$39.26	\$9.40	\$23.12	\$0.00	\$71.78
7	90	\$44.16	\$9.40	\$23.12	\$0.00	\$76.68
8	90	\$44.16	\$9.40	\$23.12	\$0.00	\$76.68

**Notes:**

% Indentured After 10/1/17; 45/45/55/55/70/70/80/80  
 Step 1&2 \$34.01/ 3&4 \$41.46/ 5&6 \$62.80/ 7&8 \$69.25

**Apprentice to Journeyworker Ratio:1:5**

PIPEFITTER & STEAMFITTER PIPEFITTERS LOCAL 537	03/01/2021	\$57.94	\$11.70	\$20.24	\$0.00	\$89.88
---	------------	---------	---------	---------	--------	---------

**Apprentice - PIPEFITTER - Local 537**

**Effective Date - 03/01/2021**

Step	percent	Apprentice Base Wage	Health	Pension	Supplemental Unemployment	Total Rate
1	40	\$23.18	\$11.70	\$8.25	\$0.00	\$43.13
2	45	\$26.07	\$11.70	\$20.24	\$0.00	\$58.01
3	60	\$34.76	\$11.70	\$20.24	\$0.00	\$66.70
4	70	\$40.56	\$11.70	\$20.24	\$0.00	\$72.50
5	80	\$46.35	\$11.70	\$20.24	\$0.00	\$78.29

**Notes:**

\*\* 1:3; 3:15; 1:10 thereafter / Steps are 1 yr.  
 Refrig/AC Mechanic \*\*1:1;1:2;2:4;3:6;4:8;5:10;6:12;7:14;8:17;9:20;10:23(Max)

**Apprentice to Journeyworker Ratio:\*\***

PIPELAYER LABORERS - ZONE 1	12/01/2021	\$41.43	\$9.10	\$17.57	\$0.00	\$68.10
	06/01/2022	\$42.43	\$9.10	\$17.57	\$0.00	\$69.10
	12/01/2022	\$43.43	\$9.10	\$17.57	\$0.00	\$70.10
	06/01/2023	\$44.43	\$9.10	\$17.57	\$0.00	\$71.10
	12/01/2023	\$45.68	\$9.10	\$17.57	\$0.00	\$72.35

For apprentice rates see "Apprentice- LABORER"

PIPELAYER (HEAVY & HIGHWAY) LABORERS - ZONE 1 (HEAVY & HIGHWAY)	12/01/2021	\$41.43	\$9.10	\$17.57	\$0.00	\$68.10
--	------------	---------	--------	---------	--------	---------

For apprentice rates see "Apprentice- LABORER (Heavy and Highway)"

Classification	Effective Date	Base Wage	Health	Pension	Supplemental Unemployment	Total Rate
PLUMBERS & GASFITTERS <i>PLUMBERS &amp; GASFITTERS LOCAL 12</i>	09/01/2021	\$61.79	\$13.57	\$17.26	\$0.00	\$92.62
	02/27/2022	\$63.39	\$13.57	\$17.26	\$0.00	\$94.22
	09/04/2022	\$65.09	\$13.57	\$17.26	\$0.00	\$95.92
	02/26/2023	\$66.79	\$13.57	\$17.26	\$0.00	\$97.62
	09/03/2023	\$68.54	\$13.57	\$17.26	\$0.00	\$99.37
	03/03/2024	\$70.34	\$13.57	\$17.26	\$0.00	\$101.17
	09/01/2024	\$72.14	\$13.57	\$17.26	\$0.00	\$102.97
	03/02/2025	\$73.94	\$13.57	\$17.26	\$0.00	\$104.77

**Apprentice - PLUMBER/GASFITTER - Local 12**

**Effective Date - 09/01/2021**

Step	percent	Apprentice Base Wage	Health	Pension	Supplemental Unemployment	Total Rate
1	35	\$21.63	\$13.57	\$6.24	\$0.00	\$41.44
2	40	\$24.72	\$13.57	\$7.08	\$0.00	\$45.37
3	55	\$33.98	\$13.57	\$9.63	\$0.00	\$57.18
4	65	\$40.16	\$13.57	\$11.33	\$0.00	\$65.06
5	75	\$46.34	\$13.57	\$13.03	\$0.00	\$72.94

**Effective Date - 02/27/2022**

Step	percent	Apprentice Base Wage	Health	Pension	Supplemental Unemployment	Total Rate
1	35	\$22.19	\$13.57	\$6.24	\$0.00	\$42.00
2	40	\$25.36	\$13.57	\$7.08	\$0.00	\$46.01
3	55	\$34.86	\$13.57	\$9.63	\$0.00	\$58.06
4	65	\$41.20	\$13.57	\$11.33	\$0.00	\$66.10
5	75	\$47.54	\$13.57	\$13.03	\$0.00	\$74.14

**Notes:**

\*\* 1:2; 2:6; 3:10; 4:14; 5:19/Steps are 1 yr  
Step4 with lic\$69.00, Step5 with lic\$76.87

**Apprentice to Journeyworker Ratio:\*\***

PNEUMATIC CONTROLS (TEMP.) <i>PIPEFITTERS LOCAL 537</i>	03/01/2021	\$57.94	\$11.70	\$20.24	\$0.00	\$89.88
--	------------	---------	---------	---------	--------	---------

For apprentice rates see "Apprentice- PIPEFITTER" or "PLUMBER/PIPEFITTER"

PNEUMATIC DRILL/TOOL OPERATOR <i>LABORERS - ZONE 1</i>	12/01/2021	\$41.43	\$9.10	\$17.57	\$0.00	\$68.10
	06/01/2022	\$42.43	\$9.10	\$17.57	\$0.00	\$69.10
	12/01/2022	\$43.43	\$9.10	\$17.57	\$0.00	\$70.10
	06/01/2023	\$44.43	\$9.10	\$17.57	\$0.00	\$71.10
	12/01/2023	\$45.68	\$9.10	\$17.57	\$0.00	\$72.35

For apprentice rates see "Apprentice- LABORER"

PNEUMATIC DRILL/TOOL OPERATOR (HEAVY & HIGHWAY) <i>LABORERS - ZONE 1 (HEAVY &amp; HIGHWAY)</i>	12/01/2021	\$41.43	\$9.10	\$17.57	\$0.00	\$68.10
---	------------	---------	--------	---------	--------	---------

For apprentice rates see "Apprentice- LABORER (Heavy and Highway)"

<b>Classification</b>	<b>Effective Date</b>	<b>Base Wage</b>	<b>Health</b>	<b>Pension</b>	<b>Supplemental Unemployment</b>	<b>Total Rate</b>
<b>POWDERMAN &amp; BLASTER</b> <i>LABORERS - ZONE 1</i>	12/01/2021	\$42.18	\$9.10	\$17.57	\$0.00	\$68.85
	06/01/2022	\$43.18	\$9.10	\$17.57	\$0.00	\$69.85
	12/01/2022	\$44.18	\$9.10	\$17.57	\$0.00	\$70.85
	06/01/2023	\$45.18	\$9.10	\$17.57	\$0.00	\$71.85
	12/01/2023	\$46.43	\$9.10	\$17.57	\$0.00	\$73.10
For apprentice rates see "Apprentice- LABORER"						
<b>POWDERMAN &amp; BLASTER (HEAVY &amp; HIGHWAY)</b> <i>LABORERS - ZONE 1 (HEAVY &amp; HIGHWAY)</i>	12/01/2021	\$42.18	\$9.10	\$17.57	\$0.00	\$68.85
For apprentice rates see "Apprentice- LABORER (Heavy and Highway)"						
<b>POWER SHOVEL/DERRICK/TRENCHING MACHINE</b> <i>OPERATING ENGINEERS LOCAL 4</i>	12/01/2021	\$51.38	\$14.00	\$16.05	\$0.00	\$81.43
For apprentice rates see "Apprentice- OPERATING ENGINEERS"						
<b>PUMP OPERATOR (CONCRETE)</b> <i>OPERATING ENGINEERS LOCAL 4</i>	12/01/2021	\$51.38	\$14.00	\$16.05	\$0.00	\$81.43
For apprentice rates see "Apprentice- OPERATING ENGINEERS"						
<b>PUMP OPERATOR (DEWATERING, OTHER)</b> <i>OPERATING ENGINEERS LOCAL 4</i>	12/01/2021	\$33.69	\$14.00	\$16.05	\$0.00	\$63.74
For apprentice rates see "Apprentice- OPERATING ENGINEERS"						
<b>READY-MIX CONCRETE DRIVER</b> <i>TEAMSTERS 170 - Rosenfeld (Walpole)</i>	01/01/2022	\$25.00	\$11.96	\$8.00	\$0.00	\$44.96
	05/01/2022	\$25.75	\$11.96	\$8.00	\$0.00	\$45.71
	01/01/2023	\$25.75	\$12.46	\$8.00	\$0.00	\$46.21
	05/01/2023	\$26.40	\$12.46	\$8.00	\$0.00	\$46.86
	01/01/2024	\$26.40	\$12.96	\$8.00	\$0.00	\$47.36
	05/01/2024	\$27.00	\$12.96	\$8.00	\$0.00	\$47.96
	01/01/2025	\$27.00	\$13.46	\$8.00	\$0.00	\$48.46
	05/01/2025	\$27.60	\$13.46	\$8.25	\$0.00	\$49.31
	01/01/2026	\$27.60	\$13.96	\$8.25	\$0.00	\$49.81
<b>RECLAIMERS</b> <i>OPERATING ENGINEERS LOCAL 4</i>	12/01/2021	\$50.83	\$14.00	\$16.05	\$0.00	\$80.88
For apprentice rates see "Apprentice- OPERATING ENGINEERS"						
<b>RIDE-ON MOTORIZED BUGGY OPERATOR</b> <i>LABORERS - ZONE 1</i>	12/01/2021	\$41.43	\$9.10	\$17.57	\$0.00	\$68.10
	06/01/2022	\$42.43	\$9.10	\$17.57	\$0.00	\$69.10
	12/01/2022	\$43.43	\$9.10	\$17.57	\$0.00	\$70.10
	06/01/2023	\$44.43	\$9.10	\$17.57	\$0.00	\$71.10
	12/01/2023	\$45.68	\$9.10	\$17.57	\$0.00	\$72.35
For apprentice rates see "Apprentice- LABORER"						
<b>ROLLER/SPREADER/MULCHING MACHINE</b> <i>OPERATING ENGINEERS LOCAL 4</i>	12/01/2021	\$50.83	\$14.00	\$16.05	\$0.00	\$80.88
For apprentice rates see "Apprentice- OPERATING ENGINEERS"						
<b>ROOFER (Inc.Roofer Waterproofng &amp;Roofer Damproofg)</b> <i>ROOFERS LOCAL 33</i>	08/01/2021	\$47.03	\$12.28	\$18.15	\$0.00	\$77.46
	02/01/2022	\$47.03	\$12.28	\$19.45	\$0.00	\$78.76

**Classification**

**Effective Date    Base Wage    Health    Pension    Supplemental Unemployment    Total Rate**

**Apprentice - ROOFER - Local 33**

**Effective Date - 08/01/2021**

Step	percent	Apprentice Base Wage	Health	Pension	Supplemental Unemployment	Total Rate
1	50	\$23.52	\$12.28	\$4.56	\$0.00	\$40.36
2	60	\$28.22	\$12.28	\$18.15	\$0.00	\$58.65
3	65	\$30.57	\$12.28	\$18.15	\$0.00	\$61.00
4	75	\$35.27	\$12.28	\$18.15	\$0.00	\$65.70
5	85	\$39.98	\$12.28	\$18.15	\$0.00	\$70.41

**Effective Date - 02/01/2022**

Step	percent	Apprentice Base Wage	Health	Pension	Supplemental Unemployment	Total Rate
1	50	\$23.52	\$12.28	\$5.21	\$0.00	\$41.01
2	60	\$28.22	\$12.28	\$19.45	\$0.00	\$59.95
3	65	\$30.57	\$12.28	\$19.45	\$0.00	\$62.30
4	75	\$35.27	\$12.28	\$19.45	\$0.00	\$67.00
5	85	\$39.98	\$12.28	\$19.45	\$0.00	\$71.71

**Notes:** \*\* 1:5, 2:6-10, the 1:10; Reroofing: 1:4, then 1:1  
 Step 1 is 2000 hrs.; Steps 2-5 are 1000 hrs.  
 (Hot Pitch Mechanics' receive \$1.00 hr. above ROOFER)

**Apprentice to Journeyworker Ratio:\*\***

ROOFER SLATE / TILE / PRECAST CONCRETE ROOFERS LOCAL 33	08/01/2021	\$47.28	\$12.28	\$18.15	\$0.00	\$77.71
	02/01/2022	\$47.28	\$12.28	\$19.45	\$0.00	\$79.01
For apprentice rates see "Apprentice- ROOFER"						
SHEETMETAL WORKER SHEETMETAL WORKERS LOCAL 17 - A	08/01/2021	\$51.95	\$13.80	\$25.60	\$2.74	\$94.09
	02/01/2022	\$53.70	\$13.80	\$25.60	\$2.79	\$95.89

**Classification**

**Effective Date    Base Wage    Health    Pension    Supplemental Unemployment    Total Rate**

**Apprentice - SHEET METAL WORKER - Local 17-A**

**Effective Date - 08/01/2021**

Step	percent	Apprentice Base Wage	Health	Pension	Supplemental Unemployment	Total Rate
1	42	\$21.82	\$13.80	\$6.01	\$0.00	\$41.63
2	42	\$21.82	\$13.80	\$6.01	\$0.00	\$41.63
3	47	\$24.42	\$13.80	\$11.26	\$1.48	\$50.96
4	47	\$24.42	\$13.80	\$11.26	\$1.48	\$50.96
5	52	\$27.01	\$13.80	\$12.23	\$1.59	\$54.63
6	52	\$27.01	\$13.80	\$12.48	\$1.60	\$54.89
7	60	\$31.17	\$13.80	\$13.87	\$1.77	\$60.61
8	65	\$33.77	\$13.80	\$14.84	\$1.87	\$64.28
9	75	\$38.96	\$13.80	\$16.77	\$2.09	\$71.62
10	85	\$44.16	\$13.80	\$18.20	\$2.28	\$78.44

**Effective Date - 02/01/2022**

Step	percent	Apprentice Base Wage	Health	Pension	Supplemental Unemployment	Total Rate
1	42	\$22.55	\$13.80	\$6.01	\$0.00	\$42.36
2	42	\$22.55	\$13.80	\$6.01	\$0.00	\$42.36
3	47	\$25.24	\$13.80	\$11.26	\$1.51	\$51.81
4	47	\$25.24	\$13.80	\$11.26	\$1.51	\$51.81
5	52	\$27.92	\$13.80	\$12.23	\$1.62	\$55.57
6	52	\$27.92	\$13.80	\$12.48	\$1.63	\$55.83
7	60	\$32.22	\$13.80	\$13.87	\$1.80	\$61.69
8	65	\$34.91	\$13.80	\$14.84	\$1.91	\$65.46
9	75	\$40.28	\$13.80	\$16.77	\$2.13	\$72.98
10	85	\$45.65	\$13.80	\$18.20	\$2.33	\$79.98

**Notes:**

Steps are 6 mos.

**Apprentice to Journeyworker Ratio:1:4**

SPECIALIZED EARTH MOVING EQUIP < 35 TONS <i>TEAMSTERS JOINT COUNCIL NO. 10 ZONE A</i>	12/01/2021	\$37.34	\$13.41	\$16.01	\$0.00	\$66.76
SPECIALIZED EARTH MOVING EQUIP > 35 TONS <i>TEAMSTERS JOINT COUNCIL NO. 10 ZONE A</i>	12/01/2021	\$37.63	\$13.41	\$16.01	\$0.00	\$67.05
SPRINKLER FITTER <i>SPRINKLER FITTERS LOCAL 550 - (Section A) Zone 1</i>	03/01/2021	\$62.45	\$10.00	\$21.25	\$0.00	\$93.70

**Classification**

**Effective Date    Base Wage    Health    Pension    Supplemental Unemployment    Total Rate**

**Apprentice - SPRINKLER FITTER - Local 550 (Section A) Zone 1**

**Effective Date - 03/01/2021**

Step	percent	Apprentice Base Wage	Health	Pension	Supplemental Unemployment	Total Rate
1	35	\$21.86	\$10.00	\$11.99	\$0.00	\$43.85
2	40	\$24.98	\$10.00	\$12.70	\$0.00	\$47.68
3	45	\$28.10	\$10.00	\$13.41	\$0.00	\$51.51
4	50	\$31.23	\$10.00	\$14.13	\$0.00	\$55.36
5	55	\$34.35	\$10.00	\$14.84	\$0.00	\$59.19
6	60	\$37.47	\$10.00	\$15.55	\$0.00	\$63.02
7	65	\$40.59	\$10.00	\$16.26	\$0.00	\$66.85
8	70	\$43.72	\$10.00	\$16.98	\$0.00	\$70.70
9	75	\$46.84	\$10.00	\$17.69	\$0.00	\$74.53
10	80	\$49.96	\$10.00	\$18.40	\$0.00	\$78.36

**Notes:** Apprentice entered prior 9/30/10:  
40/45/50/55/60/65/70/75/80/85  
Steps are 850 hours

**Apprentice to Journeyworker Ratio:1:3**

STEAM BOILER OPERATOR <i>OPERATING ENGINEERS LOCAL 4</i>	12/01/2021	\$50.83	\$14.00	\$16.05	\$0.00	\$80.88
For apprentice rates see "Apprentice- OPERATING ENGINEERS"						
TAMPERS, SELF-PROPELLED OR TRACTOR DRAWN <i>OPERATING ENGINEERS LOCAL 4</i>	12/01/2021	\$50.83	\$14.00	\$16.05	\$0.00	\$80.88
For apprentice rates see "Apprentice- OPERATING ENGINEERS"						
TELECOMMUNICATION TECHNICIAN <i>ELECTRICIANS LOCAL 103</i>	09/01/2021	\$43.40	\$13.00	\$18.37	\$0.00	\$74.77
	03/01/2022	\$44.71	\$13.00	\$18.74	\$0.00	\$76.45
	09/01/2022	\$46.42	\$13.00	\$18.87	\$0.00	\$78.29
	03/01/2023	\$48.34	\$13.00	\$19.01	\$0.00	\$80.35

**Classification**

**Effective Date    Base Wage    Health    Pension    Supplemental Unemployment    Total Rate**

**Apprentice - TELECOMMUNICATION TECHNICIAN - Local 103**

**Effective Date - 09/01/2021**

Step	percent	Apprentice Base Wage	Health	Pension	Supplemental Unemployment	Total Rate
1	45	\$19.53	\$13.00	\$0.59	\$0.00	\$33.12
2	45	\$19.53	\$13.00	\$0.59	\$0.00	\$33.12
3	50	\$21.70	\$13.00	\$14.75	\$0.00	\$49.45
4	50	\$21.70	\$13.00	\$14.75	\$0.00	\$49.45
5	55	\$23.87	\$13.00	\$15.12	\$0.00	\$51.99
6	60	\$26.04	\$13.00	\$15.47	\$0.00	\$54.51
7	65	\$28.21	\$13.00	\$15.84	\$0.00	\$57.05
8	70	\$30.38	\$13.00	\$16.20	\$0.00	\$59.58
9	75	\$32.55	\$13.00	\$16.57	\$0.00	\$62.12
10	80	\$34.72	\$13.00	\$16.92	\$0.00	\$64.64

**Effective Date - 03/01/2022**

Step	percent	Apprentice Base Wage	Health	Pension	Supplemental Unemployment	Total Rate
1	45	\$20.12	\$13.00	\$0.60	\$0.00	\$33.72
2	45	\$20.12	\$13.00	\$0.60	\$0.00	\$33.72
3	50	\$22.36	\$13.00	\$15.02	\$0.00	\$50.38
4	50	\$22.36	\$13.00	\$15.02	\$0.00	\$50.38
5	55	\$24.59	\$13.00	\$15.39	\$0.00	\$52.98
6	60	\$26.83	\$13.00	\$15.74	\$0.00	\$55.57
7	65	\$29.06	\$13.00	\$16.11	\$0.00	\$58.17
8	70	\$31.30	\$13.00	\$16.48	\$0.00	\$60.78
9	75	\$33.53	\$13.00	\$16.85	\$0.00	\$63.38
10	80	\$35.77	\$13.00	\$17.20	\$0.00	\$65.97

**Notes:**

**Apprentice to Journeyworker Ratio:1:1**

TERRAZZO FINISHERS	08/01/2021	\$56.09	\$11.39	\$22.25	\$0.00	\$89.73
BRICKLAYERS LOCAL 3 - MARBLE & TILE	02/01/2022	\$56.09	\$11.39	\$22.34	\$0.00	\$89.82



**Apprentice - TERRAZZO FINISHER - Local 3 Marble & Tile**

**Effective Date - 08/01/2021**

Step	percent	Apprentice Base Wage	Health	Pension	Supplemental Unemployment	Total Rate
1	50	\$28.05	\$11.39	\$22.25	\$0.00	\$61.69
2	60	\$33.65	\$11.39	\$22.25	\$0.00	\$67.29
3	70	\$39.26	\$11.39	\$22.25	\$0.00	\$72.90
4	80	\$44.87	\$11.39	\$22.25	\$0.00	\$78.51
5	90	\$50.48	\$11.39	\$22.25	\$0.00	\$84.12

**Effective Date - 02/01/2022**

Step	percent	Apprentice Base Wage	Health	Pension	Supplemental Unemployment	Total Rate
1	50	\$28.05	\$11.39	\$22.34	\$0.00	\$61.78
2	60	\$33.65	\$11.39	\$22.34	\$0.00	\$67.38
3	70	\$39.26	\$11.39	\$22.34	\$0.00	\$72.99
4	80	\$44.87	\$11.39	\$22.34	\$0.00	\$78.60
5	90	\$50.48	\$11.39	\$22.34	\$0.00	\$84.21

**Notes:**

**Apprentice to Journeyworker Ratio:1:3**

TEST BORING DRILLER <i>LABORERS - FOUNDATION AND MARINE</i>	12/01/2021	\$42.58	\$9.10	\$17.72	\$0.00	\$69.40
--	------------	---------	--------	---------	--------	---------

For apprentice rates see "Apprentice- LABORER"

TEST BORING DRILLER HELPER <i>LABORERS - FOUNDATION AND MARINE</i>	12/01/2021	\$41.30	\$9.10	\$17.72	\$0.00	\$68.12
---	------------	---------	--------	---------	--------	---------

For apprentice rates see "Apprentice- LABORER"

TEST BORING LABORER <i>LABORERS - FOUNDATION AND MARINE</i>	12/01/2021	\$41.18	\$9.10	\$17.72	\$0.00	\$68.00
--	------------	---------	--------	---------	--------	---------

For apprentice rates see "Apprentice- LABORER"

TRACTORS/PORTABLE STEAM GENERATORS <i>OPERATING ENGINEERS LOCAL 4</i>	12/01/2021	\$50.83	\$14.00	\$16.05	\$0.00	\$80.88
--	------------	---------	---------	---------	--------	---------

For apprentice rates see "Apprentice- OPERATING ENGINEERS"

TRAILERS FOR EARTH MOVING EQUIPMENT <i>TEAMSTERS JOINT COUNCIL NO. 10 ZONE A</i>	12/01/2021	\$37.92	\$13.41	\$16.01	\$0.00	\$67.34
---	------------	---------	---------	---------	--------	---------

TUNNEL WORK - COMPRESSED AIR <i>LABORERS (COMPRESSED AIR)</i>	12/01/2021	\$53.41	\$9.10	\$18.17	\$0.00	\$80.68
--	------------	---------	--------	---------	--------	---------

For apprentice rates see "Apprentice- LABORER"

TUNNEL WORK - COMPRESSED AIR (HAZ. WASTE) <i>LABORERS (COMPRESSED AIR)</i>	12/01/2021	\$55.41	\$9.10	\$18.17	\$0.00	\$82.68
---	------------	---------	--------	---------	--------	---------

For apprentice rates see "Apprentice- LABORER"

TUNNEL WORK - FREE AIR <i>LABORERS (FREE AIR TUNNEL)</i>	12/01/2021	\$45.48	\$9.10	\$18.17	\$0.00	\$72.75
---	------------	---------	--------	---------	--------	---------

For apprentice rates see "Apprentice- LABORER"

TUNNEL WORK - FREE AIR (HAZ. WASTE) <i>LABORERS (FREE AIR TUNNEL)</i>	12/01/2021	\$47.48	\$9.10	\$18.17	\$0.00	\$74.75
--	------------	---------	--------	---------	--------	---------

For apprentice rates see "Apprentice- LABORER"

Classification	Effective Date	Base Wage	Health	Pension	Supplemental Unemployment	Total Rate
VAC-HAUL <i>TEAMSTERS JOINT COUNCIL NO. 10 ZONE A</i>	12/01/2021	\$37.34	\$13.41	\$16.01	\$0.00	\$66.76
WAGON DRILL OPERATOR <i>LABORERS - ZONE 1</i>	12/01/2021	\$41.43	\$9.10	\$17.57	\$0.00	\$68.10
	06/01/2022	\$42.43	\$9.10	\$17.57	\$0.00	\$69.10
	12/01/2022	\$43.43	\$9.10	\$17.57	\$0.00	\$70.10
	06/01/2023	\$44.43	\$9.10	\$17.57	\$0.00	\$71.10
	12/01/2023	\$45.68	\$9.10	\$17.57	\$0.00	\$72.35
For apprentice rates see "Apprentice- LABORER"						
WAGON DRILL OPERATOR (HEAVY & HIGHWAY) <i>LABORERS - ZONE 1 (HEAVY &amp; HIGHWAY)</i>	12/01/2021	\$41.43	\$9.10	\$17.57	\$0.00	\$68.10
For apprentice rates see "Apprentice- LABORER (Heavy and Highway)"						
WASTE WATER PUMP OPERATOR <i>OPERATING ENGINEERS LOCAL 4</i>	12/01/2021	\$51.38	\$14.00	\$16.05	\$0.00	\$81.43
For apprentice rates see "Apprentice- OPERATING ENGINEERS"						
WATER METER INSTALLER <i>PLUMBERS &amp; GASFITTERS LOCAL 12</i>	09/01/2021	\$61.79	\$13.57	\$17.26	\$0.00	\$92.62
	02/27/2022	\$63.39	\$13.57	\$17.26	\$0.00	\$94.22
	09/04/2022	\$65.09	\$13.57	\$17.26	\$0.00	\$95.92
	02/26/2023	\$66.79	\$13.57	\$17.26	\$0.00	\$97.62
	09/03/2023	\$68.54	\$13.57	\$17.26	\$0.00	\$99.37
	03/03/2024	\$70.34	\$13.57	\$17.26	\$0.00	\$101.17
	09/01/2024	\$72.14	\$13.57	\$17.26	\$0.00	\$102.97
	03/02/2025	\$73.94	\$13.57	\$17.26	\$0.00	\$104.77
For apprentice rates see "Apprentice- PLUMBER/PIPEFITTER" or "PLUMBER/GASFITTER"						

Additional Apprentice Information:

Minimum wage rates for apprentices employed on public works projects are listed above as a percentage of the pre-determined hourly wage rate established by the Commissioner under the provisions of the M.G.L. c. 149, ss. 26-27D. Apprentice ratios are established by the Division of Apprenticeship Training pursuant to M.G.L. c. 23, ss. 11E-11L.

All apprentices must be registered with the Division of Apprenticeship Training in accordance with M.G.L. c. 23, ss. 11E-11L.

All steps are six months (1000 hours.)

Ratios are expressed in allowable number of apprentices to journeymen or fraction thereof, unless otherwise specified.

\*\* Multiple ratios are listed in the comment field.

\*\*\* APP to JM; 1:1, 2:2, 2:3, 3:4, 4:4, 4:5, 4:6, 5:7, 6:7, 6:8, 6:9, 7:10, 8:10, 8:11, 8:12, 9:13, 10:13, 10:14, etc.

\*\*\*\* APP to JM; 1:1, 1:2, 2:3, 2:4, 3:5, 4:6, 4:7, 5:8, 6:9, 6:10, 7:11, 8:12, 8:13, 9:14, 10:15, 10:16, etc.

ATTACHMENT B - (MBE/EEO/AA) POLICIES

**THE COMMONWEALTH OF MASSACHUSETTS  
SUPPLEMENTAL EQUAL EMPLOYMENT OPPORTUNITY,  
ANTI-DISCRIMINATION AND AFFIRMATIVE ACTION PROGRAM**

1. Definitions

For purposes of this contract, “minority” refers to Asian-Americans, Blacks, Spanish Surname Americans, North American Indians, and Cape Verdeans. “Commission” refers to the Massachusetts Commission Against Discrimination.

II. Contractor’s Agreement

During the performance of this Contract the Contractor and all of the Subcontractors, hereinafter collectively referred to as the Contractor, for himself, the assignees and successors in interest, agree as follows:

In connection with the performance of work under this contract, the Contractor, for himself, the assignees and successors in interest, agree as follows:

In connection with the performance of work under this contract, the contractor shall not discriminate against any employee or applicant for employment because of race, color, religious creed, national origin, age or sex. The aforesaid provision shall include but not be limited to the following: employment upgrading, demotion or transfer; recruitment advertising; recruitment layoff; termination; rates of pay or other forms of compensation; conditions or privileges of employment; and selection for apprenticeship.

The Contractor shall post hereafter in conspicuous places, available for employees and applicants for employment, notices to be provided by the Commission setting forth the provisions of the Fair Employment Practices Law of the Commonwealth (M.G.L. Chapter 151B).

In connection with the performance of work under this contract, the Contractor, shall undertake in good faith affirmative action measures designed to eliminate any discriminatory barriers in the terms and conditions of employment on the grounds of race, color, religious creed, national origin, age or sex, and to eliminate and remedy any effects of such discrimination in the past. Such affirmative action shall entail positive and aggressive measure to ensure equal opportunity in the areas of hiring, upgrading, demotion or transfer, recruitment, layoff or termination, rate of compensation, and in-service or apprenticeship training programs. This affirmative action shall include all action required to guarantee equal employment opportunity for all persons, regardless of race, color, religious creed, national origin, age or sex. A purpose of this provision is to ensure to the fullest extent possible an adequate supply of skilled tradesmen for this and future Commonwealth public construction projects.

III. Remedial Action

As part of this obligation of remedial action under the foregoing section, the Contractor shall maintain on this project not less than the percent ratio of minority employee man hours to total man hours in each job category including but not limited bricklayers, carpenters, cement mason electricians, ironworkers, operating engineers, and those classes of work enumerated in Section 44C of Chapter 149 of the Massachusetts General Laws. The percentage ratio for this project is 5 percent.

In the hiring of minority journeymen, apprentices, trainees and advanced trainees, the Contractor shall rely on referrals from a multi-employer affirmative action program approved by the Commission's traditional referral methods utilized by the construction industry, and referrals from agencies, not more than three in number at any one time, designated by the Liaison Committee of the Commission.

#### IV. Records

At the discretion of the Commission there may be established for the life of the contract a body to be known as the Liaison Committee. The Liaison Committee shall be composed of one representative each from the agency or agencies administering this project, hereinafter called the administering agency, the Commission and such other representative as may be designated by the Commission in conjunction with the administering agency.

The Contractor or an agent designated by the Contractor as the on-site equal employment opportunity officer shall recognize the Liaison Committee as an affirmative action body, and shall establish a continuing working relationship with the Liaison Committee, consulting with the Liaison Committee on all matters related to minority recruitment, referral, employment and training.

The Contractor shall prepare projected manning tables on a quarterly basis. These shall be broken down into weekly projections of workers required in each trade. Copies shall be furnished one week in advance of the commencement of the period covered, and also when updated, to the Commission and Liaison Committee.

Records of employment referral orders, prepared by the Contractor, shall be made available to the Commission and Liaison Committee.

The Contractor shall prepare weekly reports in a form approved by the Commission of hours worked in each trade by each employee, identified as minority or non-minority. Copies of these shall be provided at the end of each such week to the Commission and to the Liaison Committee.

#### V. Affirmative Action in Negotiating with Minority Subcontractors

If the Contractor uses any subcontractor for any work performed under this contract, the Contractor shall take affirmative action to negotiate with qualified minority subcontractors. This affirmative action shall cover both pre-bid and post bid periods. It shall include notification to the Office of Minority Business Assistance (within the Executive Office of Communities and

Development) or its designee, while bids are in preparation, of all products, work or services for which the Contractor intends to negotiate bids.

#### VI Preference in Hiring

In the employment of journeymen, apprentices, trainees and advanced trainees, the Contractor shall give preference, first, to citizens of the Commonwealth who have served in the armed forces of the United States in time of war and have been honorably discharged there from or released for active duty therein, and who are qualified to perform the work to which the employment relates, and secondly, to citizens of the Commonwealth generally, and if such cannot be obtained in sufficient numbers, then to citizens of the United States.

The requirements of the above paragraph do not apply to any project, financed in whole or in part with Federal Funds.

#### VII. Access During Construction

A designee of the Commission and a designee of the Liaison Committee shall each have right of access to the construction site.

#### VIII. Compliance with Requirements

The Contractor shall comply with the provisions of Executive Order NO. 74, as amended by Executive Order No. 116 dated May 1, 1975, and of Chapter 151B as amended, of the Massachusetts General Laws, both of which are herein incorporated and made a part of this contract.

#### IX Non-Discrimination

The Contractor, in the performance of all work after award, and prior to completion of the contract work, will not discriminate on grounds of race, color, religious creed, national origin, age or sex in employment practices, in the selection or retention of subcontractors, or in the procurement of materials and rentals of equipment.

#### X. Solicitations for Sub-Contracts, and for the Procurement of Materials and Equipment

In all solicitations either by competitive bidding or negotiation made by the Contractor either for work to be performed under a subcontract or for the procurement of materials or equipment, each potential subcontractor or supplier shall be notified in writing by the Contractor of the Contractor's obligations under this contract relative to non-discrimination and affirmative action.

#### XI. Compliance - Information, Reports and Sanctions

1. The Contractor will provide all information and reports required by the administering agency or the Commission on instruction issued by either of them and will permit access to its facilities and any books, records, accounts and other sources of information which

may be determined by the Commission to affect the employment of personnel. This provision shall apply only to information pertinent to the Commonwealth's supplementary affirmative action contract requirements. Where information required is in the exclusive possession of another who fails or refuses this information, the Contractor shall so certify to the administering agency or the Commission as appropriate and shall set forth what efforts have been made to obtain the information.

2. Whenever the administering agency, the Commission, or the Liaison Committee believes the General Contractor or any Subcontractor may not be operating in compliance with the terms of this Section, the Commission directly or through its designated agent shall conduct an appropriate investigation, and may confer with the parties, to determine if such Contractor is operating in compliance with the terms of this Section. If the Commissioner or its agent finds the General Contractor or any subcontractor not in compliance, it shall make a preliminary report of noncompliance, and notify such Contractor in writing of such steps, as will in the judgment of the Commission or its agent bring such Contractor into compliance. In the event that such Contractor fails or refuses to fully perform such steps, the Commission shall make a final report of non-compliance, and recommend to the administering agency the imposition of one or more of the sanctions listed below. If, however, the Commission believes the General contractor or any Subcontractor has taken or is taking every possible measure to achieve compliance, it shall not make a final report of non-compliance. Within fourteen days of receipt of the recommendations of the Commission, the administering agency shall move to impose one or more of the following sanctions, as it may deem appropriate to attain full and effective enforcement.
  - a. The recovery by the administering agency from the General Contractor of 1/100 of 1% of the contract award price or \$1000 whichever sum is greater in the nature of liquidated damages or, if a Subcontractor is in non-compliance, the recovery by the administering agency from the General Contractor, to be assessed by the General Contractor as back charge against the Subcontractor, of 1/10 of 1% of the subcontractor price, or \$400 whichever sum is greater, in the nature of liquidated damages, for each week that such party fails or refuses to comply.
  - b. The suspension of any payment or part thereof due under the contract until such time as the General Contractor or any Subcontractor is able to demonstrate within a specified time his compliance with the terms of the contract.
  - c. The termination, or cancellation, of the contract, in whole or in part, unless the general Contractor or any Subcontractor is able to demonstrate within a specified time his compliance with the terms of the contract.
  - d. The denial of the General Contractor or any Subcontractor of the right to participate in any future contracts awarded by the administering agency for a period of up to three years.
3. If any time after the imposition of one or more of the above sanctions a Contractor is able to demonstrate compliance with this Section, a request may be made to the administering

agency, in consultation with the Commission, to suspend the sanctions conditionally pending a final determination by the Commission as to whether the Contractor is in compliance. Upon final determination of the Commission, the administering agency, based on the recommendation of the Commission, shall either lift the sanction or reimpose them.

4. Sanctions enumerated under Sections XI-2 shall not be imposed by the administering agency except after an adjudicatory proceeding, as that term is used in M.G.L. Chapter 30A, has been conducted. No investigation by the Commission or its agent shall be initiated without prior notice to the Contractor.

## XII. Severability

The provisions of this section are severable, and if any of these provisions shall be held unconstitutional by any court of competent jurisdiction, the decision of such court shall not effect or impair any of the remaining provisions.

## XIII. Bidder's Requirements

The bidder will comply with the minority manpower ratio and specific affirmative action steps contained herein. The bidder shall obtain from each of its subcontractors and submit to the contracting or administering agency prior to the award of any subcontract under this contract the subcontractor certification required by these bid conditions.

XIV. Subcontractors' Certification

Prior to the award for any subcontract under this Notice to Contractors, regardless of tier, the prospective subcontractor must execute and submit to the Prime Contractor the following certification, which will be deemed a part of the resulting subcontract:

SUBCONTRACTORS' CERTIFICATION

\_\_\_\_\_ certifies that:  
(Subcontractor)

1. It tends to use the following listed construction trades in the work under the subcontract:

\_\_\_\_\_ ; and

2. Will comply with the Minority manpower ratio and specific affirmative action steps contained herein.

\_\_\_\_\_  
(Signature of authorized representative of Subcontractor)

In order to ensure that the said subcontractors' certification becomes a part of all subcontracts under the prime contract, no subcontract shall be executed until an authorized representative of the Town has determined, in writing, that the said certification has been incorporated in such subcontract, regardless of tier. Any subcontract executed without such written approval shall be void.

XV. Materiality

The Requirements made of the bidder pursuant to these bid conditions are material, will govern the bidders performance on the project and will be made part of the bid.



MINIMUM MINORITY PERCENTAGES TO BE APPLIED TO STATE AND STATE ASSISTED CONTRACTS WITHIN THE COMMONWEALTH OF MASSACHUSETTS

The following percentages shall apply:

AREA

NOT LESS THAN

Boston:

- Impact Area [Jamaica Plain (part), Mattapan, South Cove, Chinatown, Bay Village, Roxbury, Dorchester, and South End].	30%
- Other parts of Boston	10%
Cambridge	12%
New Bedford	18%
Springfield	10%
All other cities and towns	5%

END OF ATTACHMENT B

ATTACHMENT C – MONTHLY PRICE ADJUSTMENTS

DOCUMENT 00811  
SPECIAL PROVISIONS  
MONTHLY PRICE ADJUSTMENT FOR HOT MIX ASPHALT (HMA) MIXTURES  
ENGLISH AND METRIC UNITS  
Revised: 07/08/2016

This provision applies to all projects using greater than 100 tons (91 megagrams) of hot mix asphalt (HMA) mixtures containing liquid asphalt cement as stipulated in the Notice to Contractors section of the bid documents.

Price Adjustments will be based on the variance in price, for the liquid asphalt component only, between the Base Price and the Period Price. They shall not include transportation or other charges. Price Adjustments will occur on a monthly basis.

**Base Price**

The Base Price of liquid asphalt on a project as listed in the Notice to Contractors section of the bid documents is a fixed price determined by the Department at the time of the bid using the same method as the determination of the Period Price detailed below. The Base Price shall be used in all bids.

**Period Price**

The Period Price is the price of liquid asphalt for each monthly period as determined by the Department using the average selling price per standard ton of PG64-28 paving grade (primary binder classification) asphalt, FOB manufacturer's terminal, as listed under the "East Coast Market - New England, Boston, Massachusetts area" section of the Poten & Partners, Inc. "Asphalt Weekly Monitor". This average selling price is listed in the issue having a publication date of the second Friday of the month and will be posted as the Period Price for that month. The Department will post this Period Price on its website at <http://www.mhd.state.ma.us/> within two (2) business days following its receipt of the relevant issue of the "Asphalt Weekly Monitor". Poten and Partners has granted the Department the right to publish this specific asphalt price information sourced from the Asphalt Weekly Monitor. This method of period price determination was formerly called the New Asphalt Period Price Method. Separate website postings using both the New Asphalt Period Price Method and the Old Asphalt Period Price Method were discontinued after June 2013.

**Price Adjustment Determination, Calculation and Payment**

The Contract Price of the HMA mixture will be paid under the respective item in the Contract. Price Adjustments, as herein provided, either upwards or downwards, will be made after the work has been performed using the monthly period price for the month during which the work was performed.

Price Adjustments will be paid only if the variance from the Base Price is 5% or more for a monthly period. The complete adjustment will be paid in all cases with no deduction of the 5% from either upward or downward adjustments.

The Price Adjustment applies only to the actual virgin liquid asphalt content in the mixture placed on the job in accordance with the Standard Specifications for Highways and Bridges, Division III, Section M3.11.03.

Price Adjustments will be separate payment items. The pay item numbers are 999.401 for a positive price adjustment (a payment) and 999.402 for a negative price adjustment (a deduction). Price Adjustments will be calculated using the following equation:

$$\text{Price Adjustment} = \text{Tons of HMA Placed} \times \text{Liquid Asphalt Content \%} \times \text{RAP Factor} \times (\text{Period Price} - \text{Base Price})$$

No Price Adjustment will be allowed beyond the Completion Date of this Contract, unless there is a Department-approved extension of time.

\*\*\*\*\* END OF DOCUMENT \*\*\*\*\*

DOCUMENT 00812

SPECIAL PROVISIONS  
MONTHLY PRICE ADJUSTMENT FOR DIESEL FUEL AND GASOLINE –  
ENGLISH UNITS

Revised: 01/26/2009

This monthly fuel price adjustment is inserted in this contract because the national and worldwide energy situation has made the future cost of fuel unpredictable. This adjustment will provide for either additional compensation to the Contractor or repayment to the Commonwealth, depending on an increase or decrease in the average price of diesel fuel or gasoline.

This adjustment will be based on fuel usage factors for various items of work developed by the Highway Research Board in Circular 158, dated July 1974. These factors will be multiplied by the quantities of work done in each item during each monthly period and further multiplied by the variance in price from the Base Price to the Period Price.

The Base Price of Diesel Fuel and Gasoline will be the price as indicated in the Department's web site ([www.mhd.state.ma.us](http://www.mhd.state.ma.us)) for the month in which the contract was bid, which includes State Tax.

The Period Price will be the average of prices charged to the State, including State Tax for the bulk purchases made during each month.

This adjustment will be effected only if the variance from the Base Price is 5% or more for a monthly period. The complete adjustment will be paid in all cases with no deduction of the 5% from either upward or downward adjustments.

No adjustment will be paid for work done beyond the extended completion date of any contract.

Any adjustment (increase or decrease) to estimated quantities made to each item at the time of final payment will have the fuel price adjustment figured at the average period price for the entire term of the project for the difference of quantity.

The fuel price adjustment will apply only to the following items of work at the fuel factors shown:

ITEMS COVERED	FUEL FACTORS	
	Diesel	Gasoline
Excavation: and Borrow Work: Items 120, 120.1, 121, 123, 124, 125, 127, 129.3, 140, 140.1, 141, 142, 143, 144., 150, 150.1, 151 and 151.1 (Both Factors used)	0.29 Gallons / CY.	0.15 Gallons / CY
Surfacing Work: All Items containing Hot Mix Asphalt	2.90 Gallons / Ton	Does Not Apply

\*\*\*\*\* END OF DOCUMENT \*\*\*\*\*

DOCUMENT 00814

SPECIAL PROVISIONS  
PRICE ADJUSTMENT FOR PORTLAND CEMENT CONCRETE MIXES

January 12, 2009

This provision applies to all projects using greater than 100 Cubic Yards (76 Cubic Meters) of Portland cement concrete containing Portland cement as stipulated in the Notice to Contractors section of the Bid Documents. This Price Adjustment will occur on a monthly basis.

The Price Adjustment will be based on the variance in price for the Portland cement component only from the Base Price to the Period Price. It shall not include transportation or other charges.

The Base Price of Portland cement on a project is a fixed price determined at the time of bid by the Department by using the same method as for the determination of the Period Price (see below) and found in the Notice to Contractors.

The Period Price of Portland cement will be determined by using the latest published price, in dollars per ton (U.S.), for Portland cement (Type I) quoted for Boston, U.S.A. in the **Construction Economics** section of *ENR Engineering News-Record* magazine or at the ENR website <http://www.enr.com> under **Construction Economics**. The Period Price will be posted on the MassHighway website the Wednesday immediately following the publishing of the monthly price in ENR, which is normally the first week of the month.

The Contract Price of the Portland cement concrete mix will be paid under the respective item in the Contract. The price adjustment, as herein provided, upwards or downwards, will be made after the work has been performed, using the monthly period price for the month during which the work was performed.

The price adjustment applies only to the actual Portland cement content in the mix placed on the job in accordance with the Standard Specifications for Highways and Bridges, Division III, Section M4.02.01. No adjustments will be made for any cement replacement materials such as fly ash or ground granulated blast furnace slag.

The Price Adjustment will be a separate payment item. It will be determined by multiplying the number of cubic yards of Portland cement concrete placed during each monthly period times the Portland cement content percentage times the variance in price between the Base Price and Period Price of Portland cement.

This Price Adjustment will be paid only if the variance from the Base Price is 5% or more for a monthly period. The complete adjustment will be paid in all cases with no deduction of the 5% from either upward or downward adjustments.

No Price Adjustment will be allowed beyond the Completion Date of this Contract, unless there is a Department-approved extension of time.

\*\*\*\*\*

\*

END OF DOCUMENT

ATTACHMENT D - TOWN OF DEDHAM DESIGN & CONSTRUCTION STANDARDS

COMMONWEALTH OF MASSACHUSETTS

**TOWN OF DEDHAM**

**DESIGN AND  
CONSTRUCTION STANDARDS  
2015**



**DEPARTMENT OF PUBLIC WORKS  
AND  
ENGINEERING DEPARTMENT**

# TOWN OF DEDHAM

## EXISTING DETAIL SURVEY STANDARDS

All surveys shall be performed in accordance with 250 CMR 6.00 and the appropriate corresponding section. The survey shall be tied to the State Plane Massachusetts Mainland Coordinate System, NAD 1983 horizontally and NAVD 1988 vertically.

Plans shall be prepared at a scale of 1"=20' or some other scale approved by the Town. The final plan shall be submitted as a "hard copy" signed and stamped by a Registered Land Surveyor as well as an electronic file compatible with AutoCAD at a minimum release of R14. The CAD file shall be produced with Grid North coincident with the "Y" axis and no "hard rotation" of entities within the drawing. The base point of the drawing shall be (0,0,0). A view rotation for cosmetic appearances of the drawing is acceptable.

The following is a detailed list of all items to be field located and included on all final plan submittals:

<b>BUILDINGS</b>	<b>TRAVELED WAYS LOCATION, SIZE, SURFACE TYPE</b>
Building corners	Curbing
Decks/ porches	Driveways
House number	Edge of pavement
Top of foundation elevation	Foot/cart paths
Top of step elevation	Parking areas
	Pavement markings
	Sidewalks
	Signage
	Walkways

<b>SEWER &amp; DRAIN STRUCTURES</b>	<b>UTILITIES WATER, GAS, ELECTRIC, TELEPHONE</b>
Manholes	Dig Safe markings
Catch basins	Fire alarm boxes
Rim elevations	Gates, Box valves, Box meters, hand holes, hydrants
Invert elevations	Light poles/ pole numbers
Pipe sizes	Overhead wire connections, guy wires
Flow direction	Record utility information
	Service connections
	Utility poles/ pole numbers



# TOWN OF DEDHAM

## EXISTING DETAIL SURVEY STANDARDS

VEGETATION/ NATURAL FEATURES	MISCELLANEOUS DETAIL
Boulders	Fencing/ type, height
Deciduous/ coniferous trees	Flagpoles
Tree sizes	Guardrails
Edge of woods	Hay bales/ silt fencing
Landscaping	Mailboxes
Ledge outcrops	Monitoring wells
Shrubs, hedges	North arrow
Water bodies	Private water wells
Wetland flags (where applicable)	Riprap slopes
	Railroad ties
	Retaining walls
	Swimming pools
	Test pits
	Yard lights

TOPOGRAPHY	PROPERTY/ RIGHT OF WAY LINES
Benchmarks (set as needed)	Abutter names/ deed references
Existing contours @ 1 foot intervals	Assessors parcel numbers
Spot elevations @ 50 foot intervals	Easements
Vertical & horizontal datum	Lot lines
	Public & private street names/ widths
	Recovered monumentation

# TOWN OF DEDHAM

## STANDARD DETAILS

<u>Layer Name</u>	<u>Layer Description</u>	<u>Color</u>	<u>Linetype</u>
Abut	Abutter Lines and Text	11	Continuous
Arrow	North Arrow	White	Continuous
Barscale	Bar Scale	White	Continuous
BD	Curves, Bearings and Distances	Red	Continuous
Control	Survey Control and Traverse Lines	White	Hidden
Control-GPS	GPS Survey Control	160	Continuous
Crowsft	Crows Feet on Property/ Lot Lines	White	Crowsft
ExBld	Existing Buildings + Text	11	Continuous
ExContours	Existing Contours - Intermediate	134	Dash4
ExConTxt	Existing Contours Text	252	Continuous
ExEase	Existing Easements	9	Easements
ExElec-rec	Existing Electric record location only	22	Hidden
ExEOW	Existing Edge of Water	12	Continuous
ExFlow	Existing Flow Lines, Ditches etc.	Red	Dash2
ExFnc	Existing Fences	240	Continuous
ExGas-rec	Existing Gas-record location only	40	Hidden
ExHicon	Existing Highlighted Contours (Index Contours)	252	Dash5
ExInv	Existing Invert Elevations	253	Continuous
ExLedge	Existing Ledge Outcrops	130	Continuous
ExPool	Existings Swimming Pools	11	Continuous
ExPrk	Existing Parking Spaces, Pavement Markings	96	Continuous

# TOWN OF DEDHAM

## STANDARD DETAILS

<u><i>Layer Name</i></u>	<u><i>Layer Description</i></u>	<u><i>Color</i></u>	<u><i>Linetype</i></u>
ExRtw	Existing Retaining Walls	241	Continuous
ExSD	Existing Sewer and Drain Lines	72	Continuous
ExSE	Existing Spot Elevations	110	Continuous
ExSW	Existing Stone Walls	241	Continuous
ExTel-rec	Existing Telephone record location only	62	Hidden
ExTree	Existing Trees, Shrubs and Tree Lines	96	Continuous
ExTrv	Existing Travelways	8	Continuous
ExTxt	Existing Text	253	Continuous
ExUtil	Existing Utilities	52	Continuous
ExWater-rec	Existing Water record location only	142	Hidden
ExWet	Existing Wetland Flag Locations & Nos.	Green	DashDot
Field	Field Survey Shots, Detail/topo	White	Continuous
Hatch	Miscellaneous Hatch Patterns	96	Continuous
Legend	Plan Legend	White	Continuous
Locus	Locus/Vacinity Map	White	Continuous
Lots	Proposed Lot Lines	10	Center2
Lottxt	Proposed Lot Line Labels - TEXT	Red	Continuous
Monuments	Boundary and Roadway Monuments	White	Continuous
NoTopo	Field Shots (not to be used for topography)	White	Continuous

# TOWN OF DEDHAM

## STANDARD DETAILS

<u>Layer Name</u>	<u>Layer Description</u>	<u>Color</u>	<u>Linetype</u>
P-All	PS, Dwg. info., WCR+Drive tables Street names, Curve tables	Magenta	Continuous
P-Basel	Proposed Baselines	Cyan	Continuous
P-Basel-t	Station Equations, Geometry	Cyan	Continuous
P-Cond	Conduit, Pull boxes	Cyan	Continuous
P-Crown	Crown Line (if different from baseline)	Red	Continuous
P-Curb	Curbs, Walks, W.C.Ramps, Back Sidewalk, Ret. Walls (0.45 PL)	Blue/Red	Continuous
P-Duct	Electrical Ducts (interconnect cable)	Cyan	Continuous
P-Ease	Temporary Construction Easements	Red	Continuous
PL	Property Lines	Green	Continuous
P-Notes	General Notes	Cyan	Continuous
PntDESC	Point Node - DESCRIPTIONS	22	Continuous
PntELEV	Point Node - ELEVATIONS	Magenta	Continuous
PntNO	Point Node - NUMBERS	White	Continuous
P-Paint	Pavement Markings	Red	Continuous
P-Paint-t	Pavement Marking Text	Cyan/Red	Continuous
P-ROW	Right of Way w/Layout Reference, Row of Way Text	Blue	Continuous
P-Sign	Signs, Mast Arms, Span Wire, Text	Cyan/Red	Continuous
P-Signal	Traffic Signals, Traffic Signal Text	Cyan/Red	Continuous
P-Slope	Top or Bottom of Slope	Magenta	Hidden2

# TOWN OF DEDHAM

## STANDARD DETAILS

<u>Layer Name</u>	<u>Layer Description</u>	<u>Color</u>	<u>Linetype</u>
P-Ties	Curb Tie Lines, Survey Ties	Cyan/White	Continuous
P-Tree	Trees, Grass, Shrub	Magenta	Continuous
ROW	Right of Way Lines	Yellow	Phantom2
ROWTXT	Right of Way TEXT	White	Continuous
SAVE	Save Layer for Property Calcs, etc. (FROZEN)	8	Continuous
Stakeout	Stakeout Information, Calcs. + Points	White	Continuous
Testpits	Testpits	Magenta	Continuous
Tmesh	Tin Lines	Magenta	Continuous
VP	ViewPorts (Paper Space)	White	Continuous
Wetbuff	Wetland Buffer Zones	14	Dash6
Wetlands	Wetland Border Lines	12	DashDot

# TEMPORARY TRAFFIC CONTROL NOTES

## GENERAL

1. ALL TEMPORARY TRAFFIC CONTROL MEASURES SHALL CONFORM TO PART VI OF THE MANUAL ON UNIFORM TRAFFIC CONTROL DEVICES (M.U.T.C.D.) 2009 EDITION, SUPPLEMENTALS THERETO, THE STANDARD SPECIFICATIONS, AND THE FOLLOWING NOTES.
2. LANE RESTRICTIONS MAY NOT REMAIN OVERNIGHT OR DURING NON-WORKING HOURS. AFTER EACH WORKING DAY, TRAFFIC CONTROL DEVICES THAT ARE NOT REQUIRED SHALL BE MOVED OFF THE ROADWAY OR FULL DEPTH CONSTRUCTION AREA AND PLACED SO AS NOT TO IMPEDE PEDESTRIAN AREAS, ABUTTER ACCESS OR CAUSE CONFUSION TO MOTORISTS. IN CERTAIN CIRCUMSTANCES, AND ONLY WITH THE APPROVAL OF THE TOWN AND THE ENGINEER, CAN LANE RESTRICTIONS REMAIN OVERNIGHT.
3. CONTRACTOR SHALL PROVIDE A SAFE TEMPORARY PEDESTRIAN ACCESS WHERE EXISTING SIDEWALKS OR OTHER PEDESTRIAN AREAS ARE AFFECTED BY CONSTRUCTION WORK. CONTRACTOR SHALL MAINTAIN ABUTTER ACCESS AT ALL TIMES EXCEPT FOR SHORT PERIODS APPROVED BY THE ENGINEER.
4. CONTRACTOR SHALL PLACE ALL CONSTRUCTION SIGNING, TRAFFIC CONTROL DEVICES AND TEMPORARY PAVEMENT MARKING FOR EACH PHASE PRIOR TO COMMENCEMENT OF CONSTRUCTION.
5. ONE (1) THRU TRAVEL LANE HAVING A MINIMUM WIDTH OF 11'-0" SHALL BE PROVIDED FOR BOTH DIRECTIONS (LANE TO BE SHARED AND DIRECTION OF TRAVEL TO ALTERNATE IN SOME SITUATIONS UNDER POLICE OFFICER CONTROL) DURING ALL PHASES OF CONSTRUCTION AS SHOWN ON THE TEMPORARY TRAFFIC CONTROL PLANS, UNLESS OTHERWISE DIRECTED BY THE ENGINEER.
6. IN THE INTEREST OF PUBLIC SAFETY AND CONVENIENCE, THE TOWN MAY, WHEN WORK INFRINGES UPON THE TRAVELED WAY, RESTRICT THE CONTRACTOR'S WORKING HOURS.

UNLESS OTHERWISE NOTED, CONSTRUCTION METHODS, MATERIAL REQUIREMENTS AND METHOD OF MEASUREMENT SHALL BE IN ACCORDANCE WITH THE LATEST EDITION OF THE MASSACHUSETTS DEPARTMENT OF TRANSPORTATION (MassDOT) STANDARD SPECIFICATIONS.

ALSO REFERENCE CURRENT MassDOT CONSTRUCTION STANDARD DETAILS.



## DEDHAM DPW DESIGN & CONSTRUCTION STANDARDS

### TEMPORARY TRAFFIC CONTROL NOTES

SCALE: NTS      DATE OF ISSUE:  
AUGUST 2015

REVISED:

DETAIL NUMBER:  
TM.01

# ROADS & SIDEWALKS

**DESCRIPTION**

**DETAIL NUMBER**

**ROADWAY & PAVEMENT**

TYPICAL ROADWAY SECTION	RS.01
TYPICAL RESIDENTIAL STREET ROADWAY SECTION (NEW SUBDIVISION)	RS.02
ROAD WIDENING & OVERLAY (LESS THAN 6' WIDE)	RS.03
ROAD WIDENING & OVERLAY (6' WIDE OR GREATER)	RS.04
PAVEMENT TRANSITION	RS.05

**DRIVEWAYS**

FULL DEPTH DRIVEWAY APRON (NO SIDEWALK)	RS.06
TYPICAL CURB CUT PLAN— RESIDENTIAL DRIVEWAYS (NO SIDEWALKS)	RS.07
TYPICAL CURB CUT PLAN—COMMERCIAL DRIVEWAYS	RS.08
FULL DEPTH DRIVEWAY APRON SECTION	RS.09

**SIDEWALKS**

HMA SIDEWALK THROUGH DRIVEWAY	RS.10
CEMENT CONCRETE SIDEWALK THROUGH DRIVEWAY	RS.11
CONCRETE WHEELCHAIR RAMPS	RS.12
DETECTABLE WARNING PANELS	RS.13
CURB TRANSITION LENGTHS FOR WHEELCHAIR RAMP	RS.14
ASPHALT OR CEMENT CONCRETE SIDEWALK	RS.15
PRECAST CONCRETE CURB & SIDEWALK	RS.16
CAST IN PLACE CONCRETE CURB & SIDEWALK	RS.17
SIDEWALK WITH GRASS STRIP	RS.18

**CURBING**

VERTICAL GRANITE CURBING—TYPE VA4	RS.19
SLOPED GRANITE EDGING	RS.20
GRANITE CURB TO SLOPED EDGING TRANSITION	RS.21
HOT MIX ASPHALT—TYPE "A"	RS.22
HOT MIX ASPHALT—TYPE 3	RS.23

UNLESS OTHERWISE NOTED, CONSTRUCTION METHODS, MATERIAL REQUIREMENTS AND METHOD OF MEASUREMENT SHALL BE IN ACCORDANCE WITH THE LATEST EDITION OF THE MASSACHUSETTS DEPARTMENT OF TRANSPORTATION (MassDOT) STANDARD SPECIFICATIONS.

ALSO REFERENCE CURRENT MassDOT CONSTRUCTION STANDARD DETAILS.



**DEDHAM DPW  
DESIGN & CONSTRUCTION STANDARDS**

DETAIL INDEX  
ROADS & SIDEWALKS

SCALE: NTS	DATE OF ISSUE: AUGUST 2015
---------------	-------------------------------

REVISED:

DETAIL NUMBER: RS—INDEX.01
-------------------------------

# ROADS & SIDEWALKS

**DESCRIPTION**

**DETAIL NUMBER**

**ISLANDS**

TRAFFIC ISLAND (VERTICAL CURBING)	RS.24
TRAFFIC ISLAND (SLOPED EDGING)	RS.25
RAISED PLANTING ISLAND DETAIL	RS.26
ISLAND REMOVAL	RS.27

**STEEL BEAM HIGHWAY GUARD (TYPE SS)**

VERTICAL GRANITE CURB OR ASPHALT CURB	RS.28
HOT MIX ASPHALT BERM-TYPE "A"	RS.29
SLOPED GRANITE EDGING	RS.30
 RIPRAP SLOPE	 RS.31
 SCORED CONCRETE PAVEMENT	 RS.32

**TRENCH REPAIRS**

SHALLOW EXCAVATION IN ASPHALT PAVEMENT ( $\leq 42"$ )	RS.33
DEEP EXCAVATION IN ASPHALT PAVEMENT ( $> 42"$ )	RS.34
PAVEMENT RESTORATION FOR TRENCHING IN CRACKED PAVEMENT	RS.35
TYPICAL ROADWAY CROSS-SECTION FOR THE ACCEPTANCE OF A PRIVATE WAY AS A PUBLIC WAY	RS.36

UNLESS OTHERWISE NOTED, CONSTRUCTION METHODS, MATERIAL REQUIREMENTS AND METHOD OF MEASUREMENT SHALL BE IN ACCORDANCE WITH THE LATEST EDITION OF THE MASSACHUSETTS DEPARTMENT OF TRANSPORTATION (MassDOT) STANDARD SPECIFICATIONS.

ALSO REFERENCE CURRENT MassDOT CONSTRUCTION STANDARD DETAILS.



**DEDHAM DPW  
DESIGN & CONSTRUCTION STANDARDS**

DETAIL INDEX  
ROADS & SIDEWALKS

SCALE: NTS	DATE OF ISSUE: AUGUST 2015
---------------	-------------------------------

REVISED:

DETAIL NUMBER: RS-INDEX.02
-------------------------------



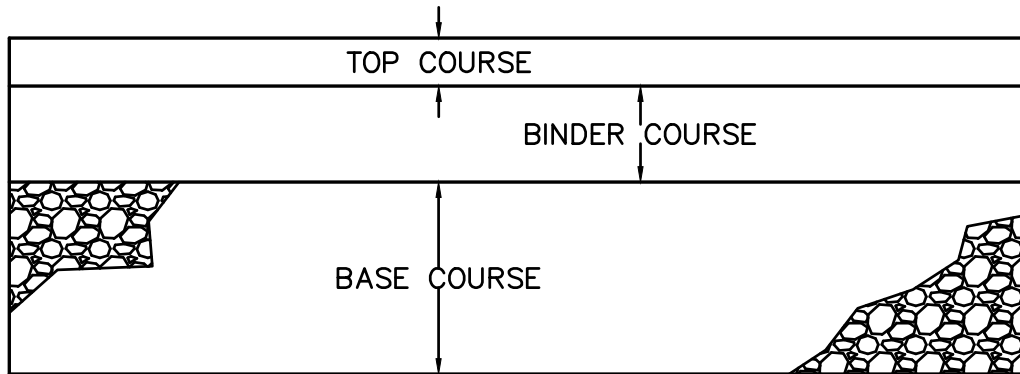

WARM MIX ASPHALT PAVEMENT CONSTRUCTION			
	ARTERIAL	COLLECTOR	LOCAL
TOP COURSE THICKNESS (IN):	2	2	1-1/2
BINDER COURSE THICKNESS (IN):	3	3	2
BASE COURSE THICKNESS (IN):	12	12	12

**NOTES:**

- 1) WARM MIX ASPHALT SHALL CONFORM TO THE LATEST VERSION OF THE MassDOT STANDARD SPECIFICATIONS.
- 2) WARM MIX ADDITIVES (WMAs) FOR FULL WIDTH ROAD CONSTRUCTION – WMAs SHALL BE ADDED TO THE JOB-MIX FORMULA UNLESS OTHERWISE DIRECTED BY THE ENGINEER. NO OTHER CHANGES SHALL BE MADE IN THE JOB-MIX FORMULA WHEN ADDING WMAs UNLESS REQUIRED BY THE ENGINEER. ONLY WMAs LISTED ON THE NEAUPG QUALIFIED WMA TECHNOLOGIES LIST WILL BE ACCEPTED, AND SHALL BE LIMITED TO CHEMICAL ADDITIVES WHICH ARE CAPABLE OF REDUCING MIXTURE COMPACTION TEMPERATURES BY A MINIMUM OF 50°F. ADDITIVES POSSESSING ANTI-STRIPPING PROPERTIES ARE PREFERRED.
- 3) BASE COURSE MATERIAL SHALL BE GRAVEL BORROW M1.03.0 TYPE "B" FOR NEW ROADWAY CONSTRUCTION AND SHALL BE EITHER GRAVEL BORROW M1.03.0 TYPE "B" OR RECLAIMED PAVEMENT BORROW M1.09.0.
- 4) A TACK COAT CONSISTING OF ASPHALT EMULSION TYPE "RS-1" SHALL BE APPLIED OVER THE BINDER COURSE AT UNIFORM RATE OF 0.05 GALLONS PER SQUARE YARD IMMEDIATELY PRIOR TO INSTALLATION OF THE TOP COURSE.
- 5) RECLAMATION DEPTH SHALL BE A MINIMUM OF 12 INCHES. IF BOTTOM OF RECLAMATION IS ABOVE REQUIRED SUBGRADE, THE RECLAIMED MATERIAL SHALL BE REMOVED, THE EXISTING SUBGRADE SHALL BE EXCAVATED TO THE REQUIRED SUBGRADE ELEVATION AND RECLAIMED MATERIAL SHALL THEN BE PLACED TO THE REQUIRED GRADES. EXISTING SUBGRADE MAY REMAIN IN PLACE IF IT MEETS THE SPECIFICATION FOR GRAVEL BORROW M1.03.0 TYPE "B".
- 6) THE DIRECTOR OF ENGINEERING AND/OR THE DIRECTOR OF PUBLIC WORKS HAVE THE RIGHT TO REQUEST THAT A ROADWAY BE DESIGNED PER THE LATEST EDITION OF THE MassDOT PROJECT DEVELOPMENT AND DESIGN GUIDEBOOK.

UNLESS OTHERWISE NOTED, CONSTRUCTION METHODS, MATERIAL REQUIREMENTS AND METHOD OF MEASUREMENT SHALL BE IN ACCORDANCE WITH THE LATEST EDITION OF THE MASSACHUSETTS DEPARTMENT OF TRANSPORTATION (MassDOT) STANDARD SPECIFICATIONS.

ALSO REFERENCE CURRENT MassDOT CONSTRUCTION STANDARD DETAILS.



**DEDHAM DPW  
DESIGN & CONSTRUCTION STANDARDS**

TYPICAL ROADWAY SECTION FOR  
VARIOUS ROAD CLASSIFICATIONS

SCALE: NTS	DATE OF ISSUE: AUGUST 2015
---------------	-------------------------------

REVISED:

DETAIL NUMBER: RS.01
-------------------------

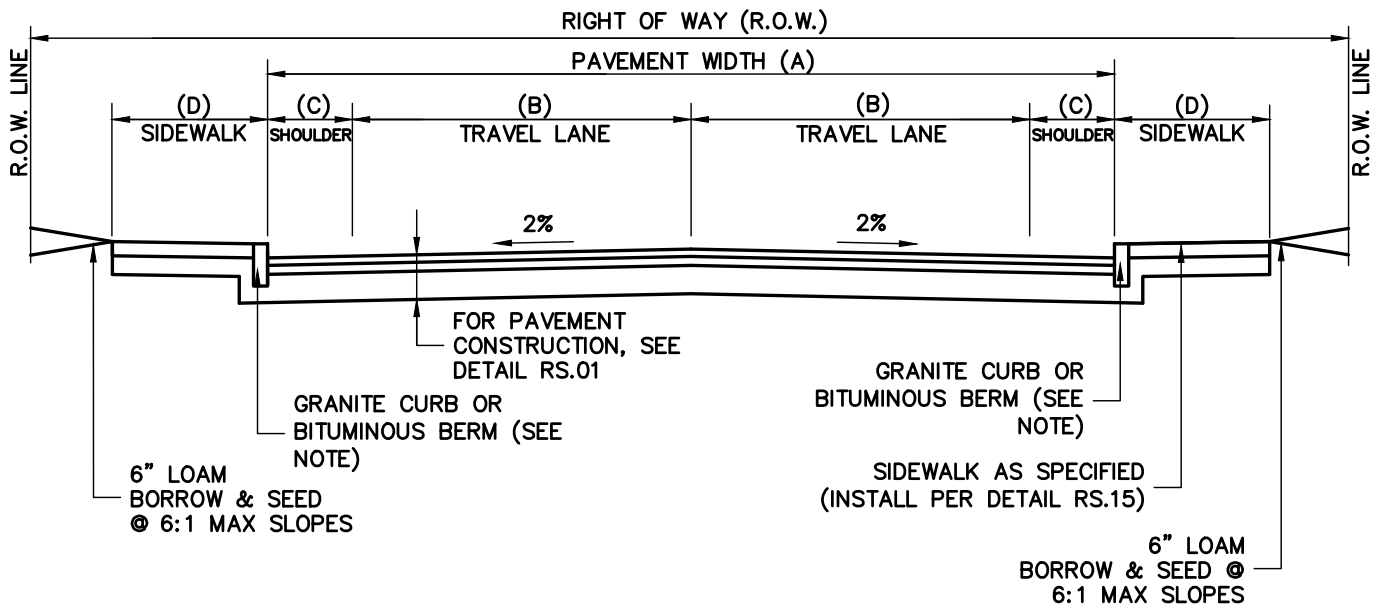

CLASSIFICATION	NO. OF LOTS SERVED	MINIMUM ROADWAY SECTION WIDTHS (FT)				
		R.O.W.	(A)	(B)	(C)	(D)
LOCAL	1-4	40	18	8	1	5
LOCAL	5-49	50	28	12	2	6
COLLECTOR	50+	60	32	12	4	6

**NOTES:**

- 1) CURB TYPE SHALL BE DETERMINED BY LOCATION IN TOWN AND CURRENT B.O.S. POLICIES.
- 2) SIDEWALKS SHALL INCORPORATE GRASS STRIPS WHERE FEASIBLE. MINIMUM GRASS STRIP WIDTHS SHALL BE 2 FEET. (SEE DETAIL RS.18)

UNLESS OTHERWISE NOTED, CONSTRUCTION METHODS, MATERIAL REQUIREMENTS AND METHOD OF MEASUREMENT SHALL BE IN ACCORDANCE WITH THE LATEST EDITION OF THE MASSACHUSETTS DEPARTMENT OF TRANSPORTATION (MassDOT) STANDARD SPECIFICATIONS.

ALSO REFERENCE CURRENT MassDOT CONSTRUCTION STANDARD DETAILS.



**DEDHAM DPW  
DESIGN & CONSTRUCTION STANDARDS**

TYPICAL RESIDENTIAL STREET ROADWAY SECTION  
NEW SUBDIVISION

SCALE: NTS      DATE OF ISSUE:  
AUGUST 2015

REVISED:

DETAIL NUMBER:  
RS.02

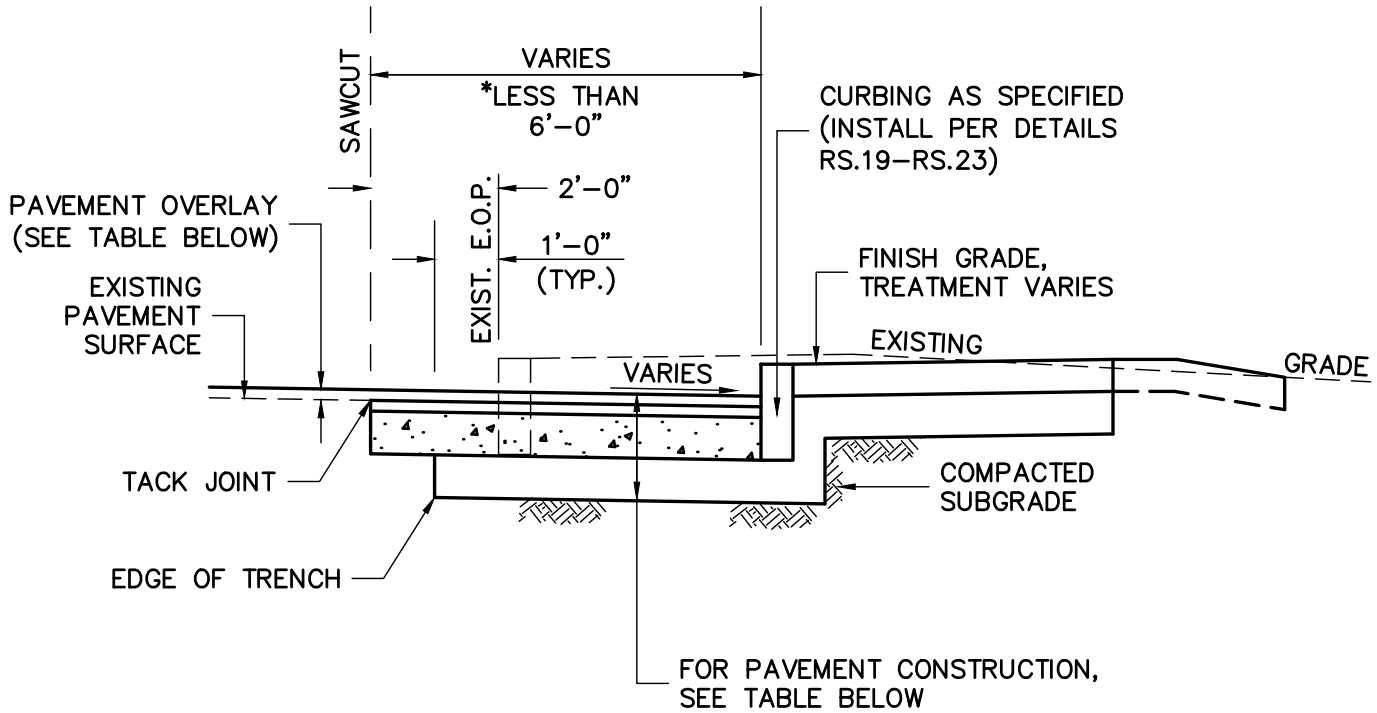

\*NOTE: FOR PROPOSED WIDENING OF 6 FEET OR GREATER IN WIDTH, SEE DRAWING RS.04

PAVEMENT CONSTRUCTION		
	FULL DEPTH CONSTRUCTION	PAVEMENT OVERLAY CONSTRUCTION
SURFACE:	4" WARM MIX ASPHALT (2" TOP COURSE MATERIAL OVER 2" BINDER COURSE MATERIAL)	2" WARM MIX ASPHALT (TOP COURSE MATERIAL)
BASE:	8" HIGH-EARLY-STRENGTH CEMENT CONCRETE BASE COURSE	
BASECOURSE:	8" GRAVEL BORROW (TYPE "B")	

UNLESS OTHERWISE NOTED, CONSTRUCTION METHODS, MATERIAL REQUIREMENTS AND METHOD OF MEASUREMENT SHALL BE IN ACCORDANCE WITH THE LATEST EDITION OF THE MASSACHUSETTS DEPARTMENT OF TRANSPORTATION (MassDOT) STANDARD SPECIFICATIONS.

ALSO REFERENCE CURRENT MassDOT CONSTRUCTION STANDARD DETAILS.



**DEDHAM DPW  
DESIGN & CONSTRUCTION STANDARDS**

ROAD WIDENING AND OVERLAY  
LESS THAN 6' WIDE

SCALE: NTS      DATE OF ISSUE: AUGUST 2015

REVISED:

DETAIL NUMBER: RS.03

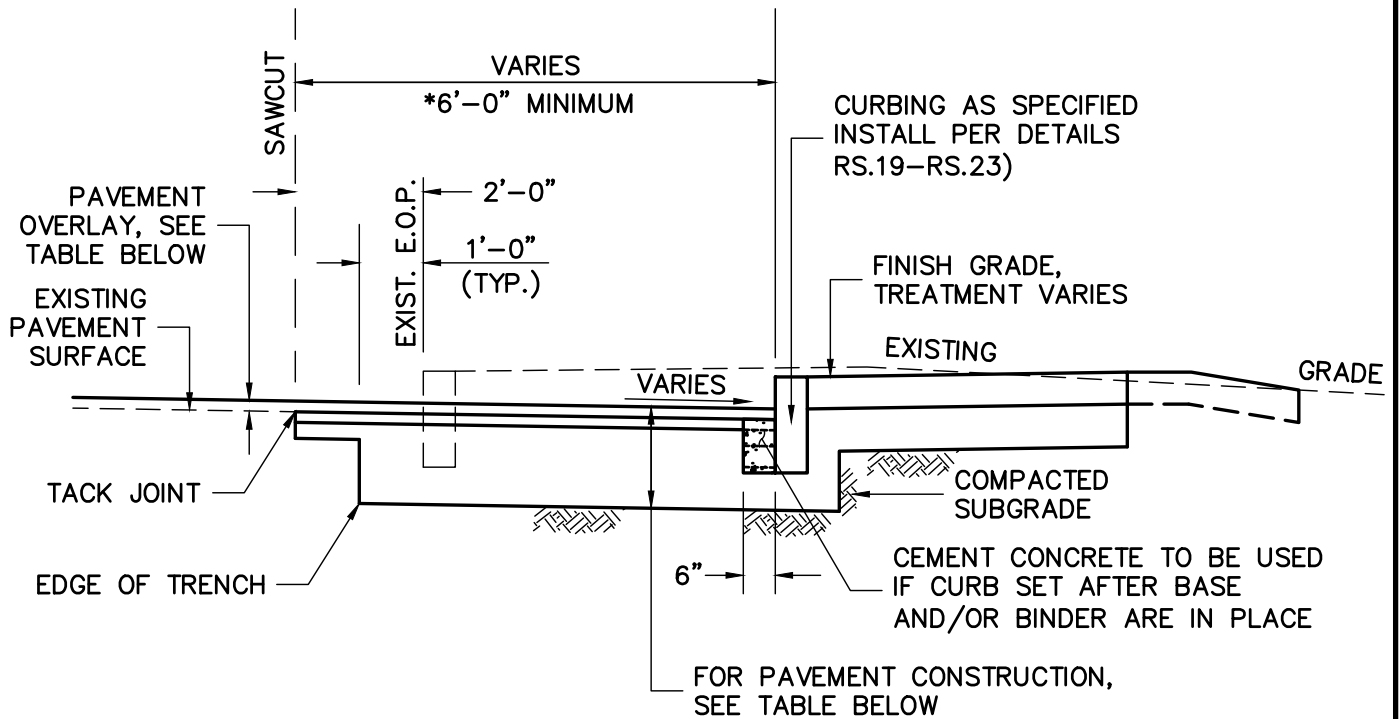

\*NOTE: FOR PROPOSED WIDENING LESS THAN 6 FEET IN WIDTH, SEE DRAWING RS.03

PAVEMENT CONSTRUCTION		
	FULL DEPTH CONSTRUCTION	PAVEMENT OVERLAY CONSTRUCTION
SURFACE:	5" WARM MIX ASPHALT (2" TOP COURSE MATERIAL OVER 3" BINDER COURSE MATERIAL)	2" WARM MIX ASPHALT (TOP COURSE MATERIAL)
BASECOURSE:	12" GRAVEL BORROW (TYPE "B")	

UNLESS OTHERWISE NOTED, CONSTRUCTION METHODS, MATERIAL REQUIREMENTS AND METHOD OF MEASUREMENT SHALL BE IN ACCORDANCE WITH THE LATEST EDITION OF THE MASSACHUSETTS DEPARTMENT OF TRANSPORTATION (MassDOT) STANDARD SPECIFICATIONS.

ALSO REFERENCE CURRENT MassDOT CONSTRUCTION STANDARD DETAILS.



**DEDHAM DPW  
DESIGN & CONSTRUCTION STANDARDS**

ROAD WIDENING AND OVERLAY  
6' WIDE OR GREATER

SCALE: NTS  
DATE OF ISSUE: AUGUST 2015

REVISED:

DETAIL NUMBER:  
RS.04

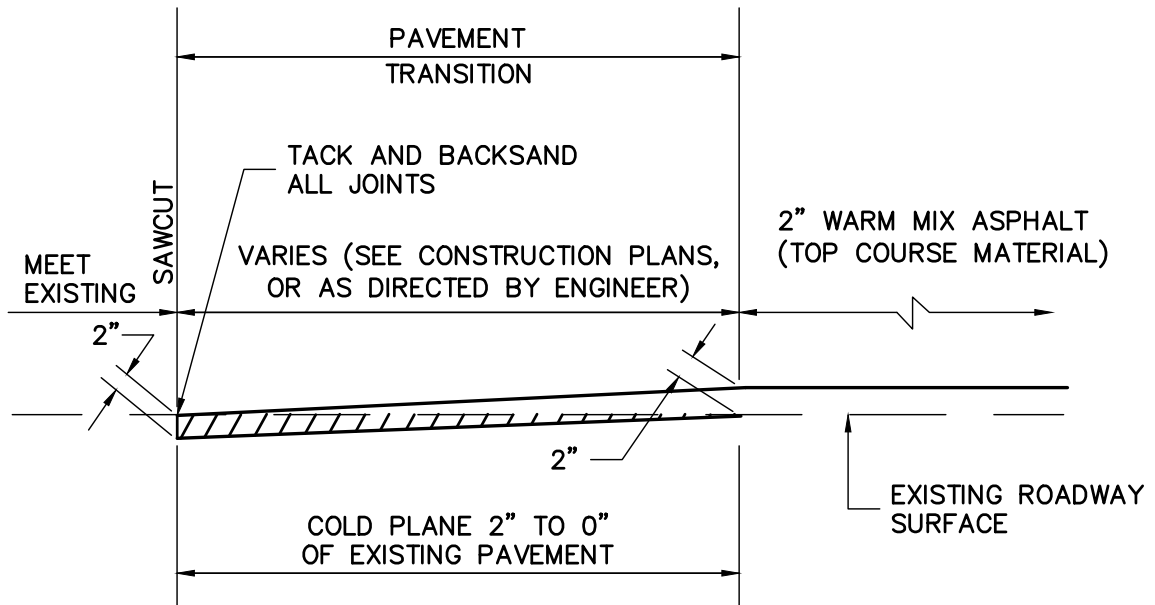

UNLESS OTHERWISE NOTED, CONSTRUCTION METHODS, MATERIAL REQUIREMENTS AND METHOD OF MEASUREMENT SHALL BE IN ACCORDANCE WITH THE LATEST EDITION OF THE MASSACHUSETTS DEPARTMENT OF TRANSPORTATION (MassDOT) STANDARD SPECIFICATIONS.

ALSO REFERENCE CURRENT MassDOT CONSTRUCTION STANDARD DETAILS.



**DEDHAM DPW  
DESIGN & CONSTRUCTION STANDARDS**

PAVEMENT TRANSITION

SCALE: NTS	DATE OF ISSUE: AUGUST 2015
---------------	-------------------------------

REVISED:

DETAIL NUMBER: RS.05
-------------------------

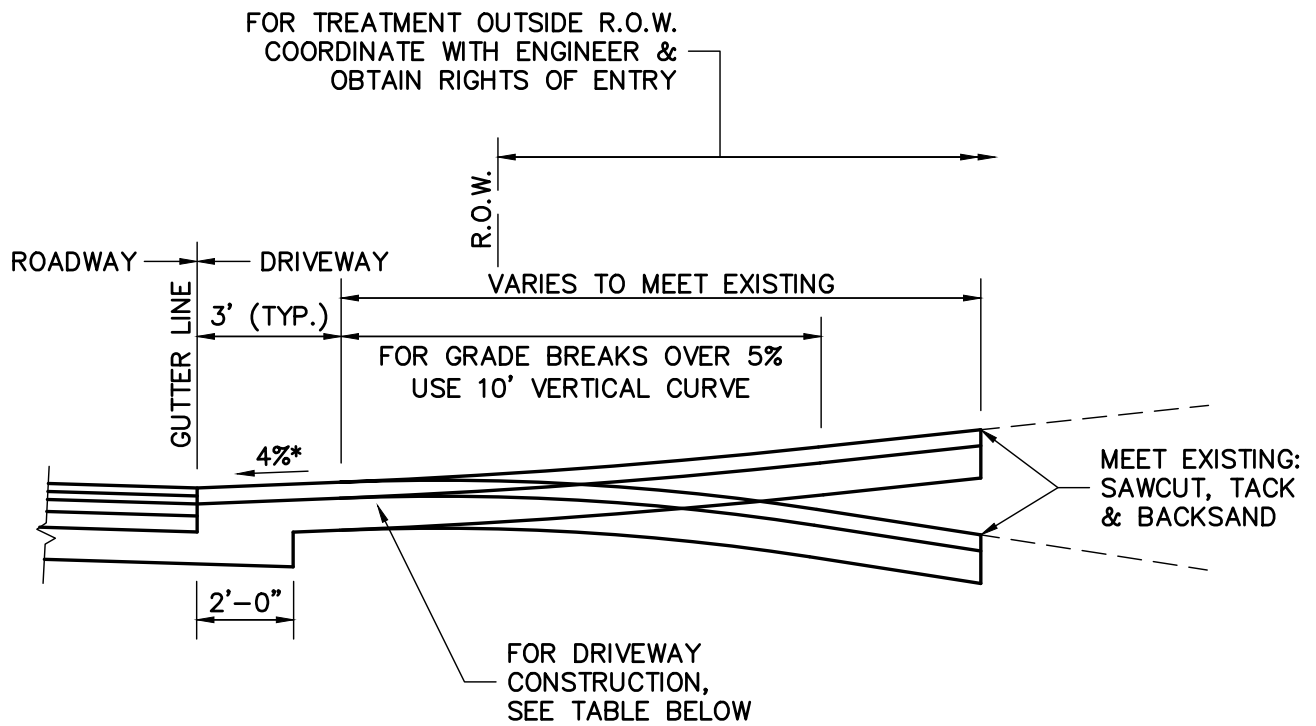

NOTE: FOR PLAN, SEE DRAWING RS.07

DRIVEWAY CONSTRUCTION		
	CEMENT CONCRETE CONSTRUCTION	HOT MIX ASPHALT
SURFACE:	6" CEMENT CONCRETE (4000 PSI, 3/4", 610 WITH 6" x 6" x #10 WIRE MESH)	3-1/2" HOT MIX ASPHALT (1-1/2" TOP COURSE MATERIAL OVER 2" BINDER COURSE MATERIAL)
BASECOURSE:	8" GRAVEL BORROW (TYPE "B")	8" GRAVEL BORROW (TYPE "B")

R.O.W. = RIGHT OF WAY

\* - MAY VARY TO MEET FIELD CONDITIONS; 1" LIP FOR CEMENT CONCRETE DRIVEWAYS

UNLESS OTHERWISE NOTED, CONSTRUCTION METHODS, MATERIAL REQUIREMENTS AND METHOD OF MEASUREMENT SHALL BE IN ACCORDANCE WITH THE LATEST EDITION OF THE MASSACHUSETTS DEPARTMENT OF TRANSPORTATION (MassDOT) STANDARD SPECIFICATIONS.

ALSO REFERENCE CURRENT MassDOT CONSTRUCTION STANDARD DETAILS.



**DEDHAM DPW  
DESIGN & CONSTRUCTION STANDARDS**

FULL DEPTH DRIVEWAY APRON — SECTION  
NO SIDEWALK

SCALE: NTS      DATE OF ISSUE:  
AUGUST 2015

REVISED:

DETAIL NUMBER:  
RS.06

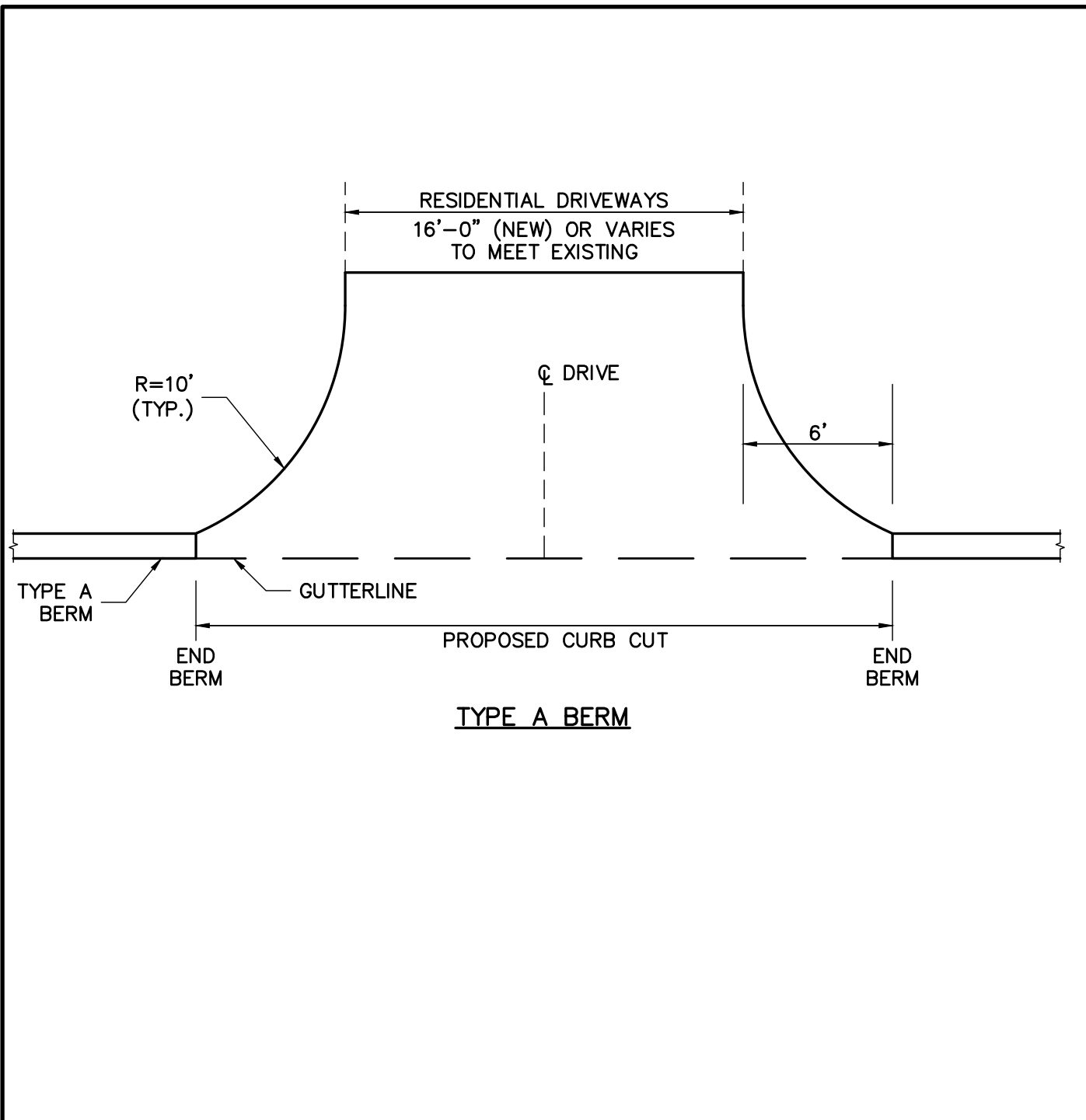

UNLESS OTHERWISE NOTED, CONSTRUCTION METHODS, MATERIAL REQUIREMENTS AND METHOD OF MEASUREMENT SHALL BE IN ACCORDANCE WITH THE LATEST EDITION OF THE MASSACHUSETTS DEPARTMENT OF TRANSPORTATION (MassDOT) STANDARD SPECIFICATIONS.

ALSO REFERENCE CURRENT MassDOT CONSTRUCTION STANDARD DETAILS.



**DEDHAM DPW  
DESIGN & CONSTRUCTION STANDARDS**

TYPICAL CURB CUT PLAN – RESIDENTIAL DRIVEWAYS  
NO SIDEWALK

SCALE: NTS      DATE OF ISSUE:  
AUGUST 2015

REVISED:

DETAIL NUMBER:  
RS.07

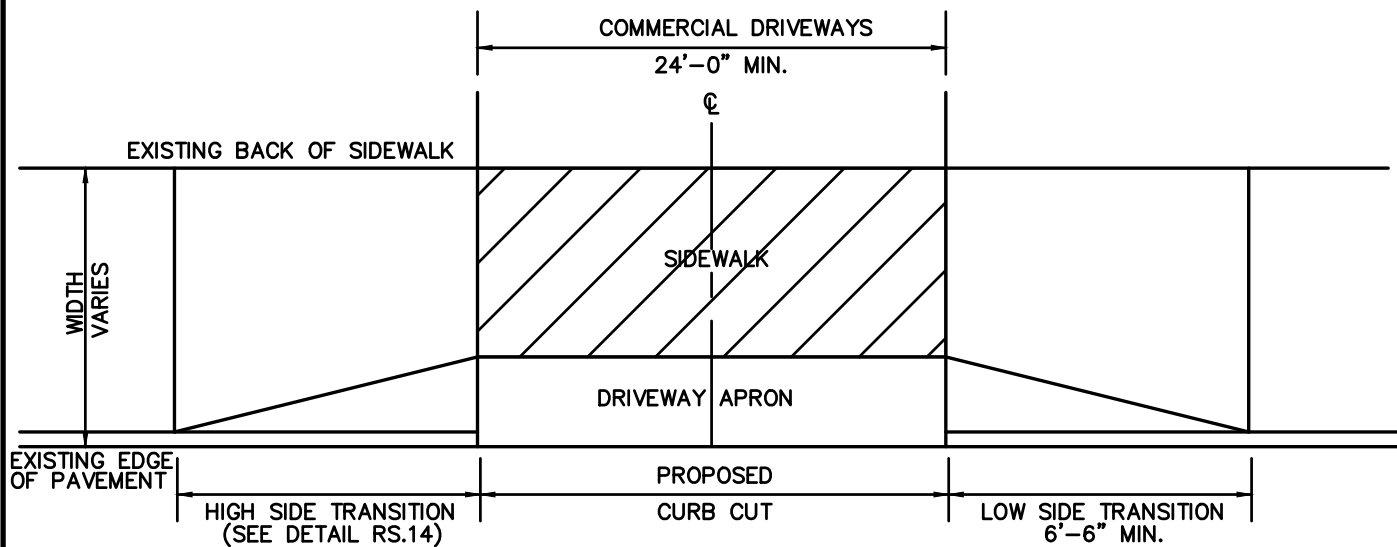

**CURB CUT WITH SIDEWALK**



MUST MAINTAIN A 3'-0" LEVEL PATH OF TRAVEL AT 1.5% CROSS SLOPE

UNLESS OTHERWISE NOTED, CONSTRUCTION METHODS, MATERIAL REQUIREMENTS AND METHOD OF MEASUREMENT SHALL BE IN ACCORDANCE WITH THE LATEST EDITION OF THE MASSACHUSETTS DEPARTMENT OF TRANSPORTATION (MassDOT) STANDARD SPECIFICATIONS.

ALSO REFERENCE CURRENT MassDOT CONSTRUCTION STANDARD DETAILS.



**DEDHAM DPW  
DESIGN & CONSTRUCTION STANDARDS**

TYPICAL CURB CUT PLAN – COMMERCIAL DRIVEWAYS  
WITH SIDEWALK

SCALE: NTS	DATE OF ISSUE: AUGUST 2015
---------------	-------------------------------

REVISED:

DETAIL NUMBER: RS.08
-------------------------



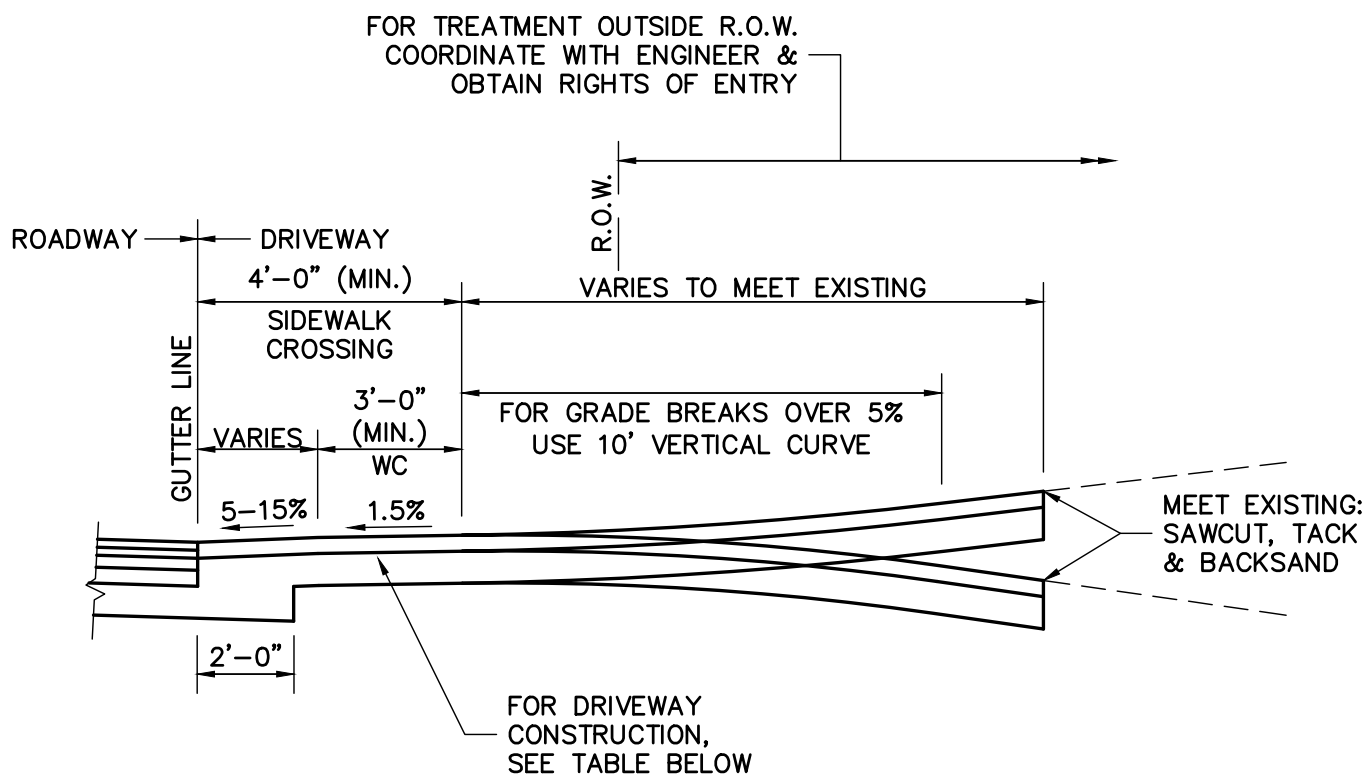

**NOTES:**

1. FOR PLAN, SEE DRAWING RS.10.
2. FOR CEMENT CONCRETE SIDEWALK SEE DRAWING RS.11.

DRIVEWAY APRON CONSTRUCTION	
SURFACE:	3-1/2" HOT MIX ASPHALT (1-1/2" TOP COURSE MATERIAL OVER 2" BINDER COURSE MATERIAL)
SUBBASE:	8" GRAVEL BORROW (TYPE "B")

WC = WHEELCHAIR (PATHWAY)  
R.O.W. = RIGHT OF WAY

UNLESS OTHERWISE NOTED, CONSTRUCTION METHODS, MATERIAL REQUIREMENTS AND METHOD OF MEASUREMENT SHALL BE IN ACCORDANCE WITH THE LATEST EDITION OF THE MASSACHUSETTS DEPARTMENT OF TRANSPORTATION (MassDOT) STANDARD SPECIFICATIONS.

ALSO REFERENCE CURRENT MassDOT CONSTRUCTION STANDARD DETAILS.



**DEDHAM DPW  
DESIGN & CONSTRUCTION STANDARDS**

FULL DEPTH DRIVEWAY APRON – SECTION  
HOT MIX ASPHALT SIDEWALK CROSSING

SCALE: NTS	DATE OF ISSUE: AUGUST 2015
REVISED:	
DETAIL NUMBER: RS.09	

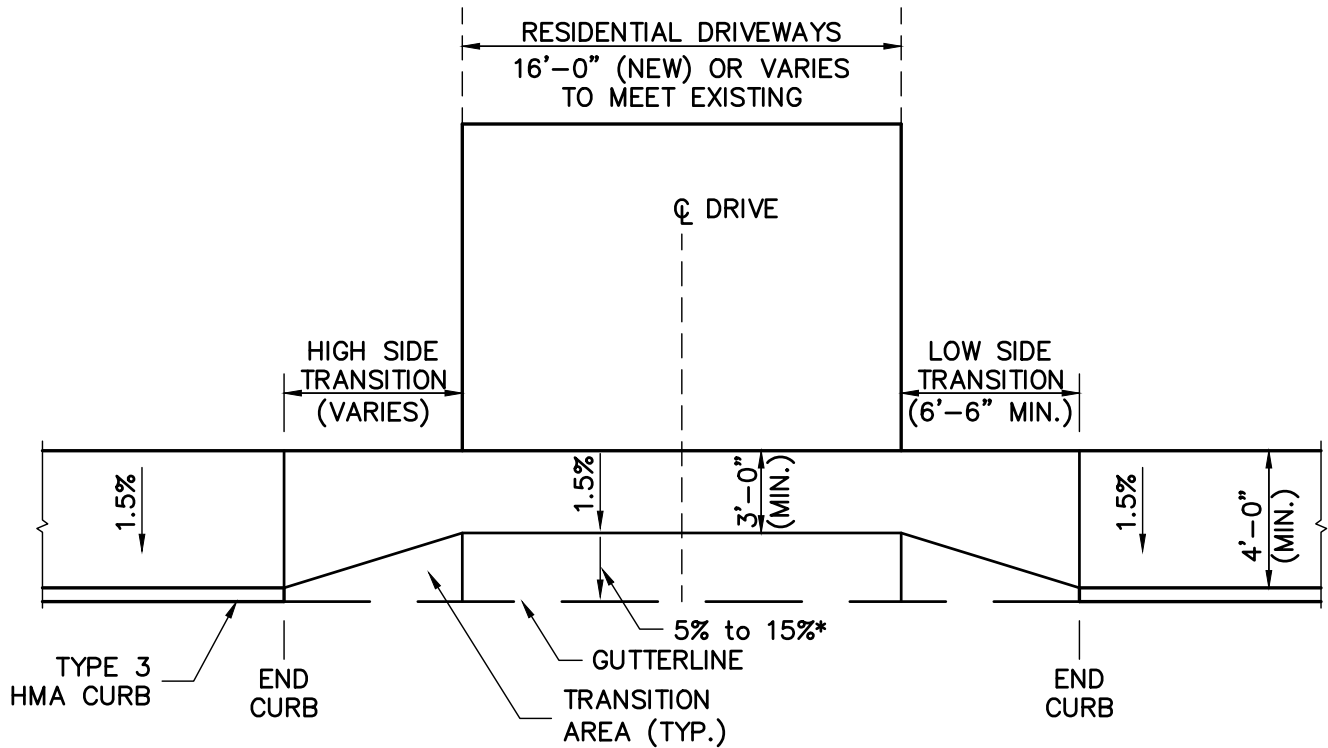

**NOTES:**

1. FOR SECTION, SEE DRAWING RS.09.
2. TRANSITION AREA TO BE HAND PLACED HMA, GRADED TO TRANSITION FROM CURB SECTION TO DRIVEWAY SECTION. SLOPE OF TRANSITION AREA PARALLEL TO GUTTERLINE IS NOT TO EXCEED 7.5%. SEE DETAIL RS.14.

**DRIVEWAY APRON CONSTRUCTION**

**SURFACE:** 3-1/2" HOT MIX ASPHALT (1-1/2" TOP COURSE MATERIAL OVER 2" BINDER COURSE MATERIAL)

**SUBBASE:** 8" GRAVEL BORROW (TYPE "B")

UNLESS OTHERWISE NOTED, CONSTRUCTION METHODS, MATERIAL REQUIREMENTS AND METHOD OF MEASUREMENT SHALL BE IN ACCORDANCE WITH THE LATEST EDITION OF THE MASSACHUSETTS DEPARTMENT OF TRANSPORTATION (MassDOT) STANDARD SPECIFICATIONS.

ALSO REFERENCE CURRENT MassDOT CONSTRUCTION STANDARD DETAILS.



**DEDHAM DPW  
DESIGN & CONSTRUCTION STANDARDS**

HOT MIX ASPHALT SIDEWALK THROUGH DRIVEWAY  
HOT MIX ASPHALT CURB – TYPE 3

SCALE: NTS	DATE OF ISSUE: AUGUST 2015
---------------	-------------------------------

REVISED:

DETAIL NUMBER:  
RS.10

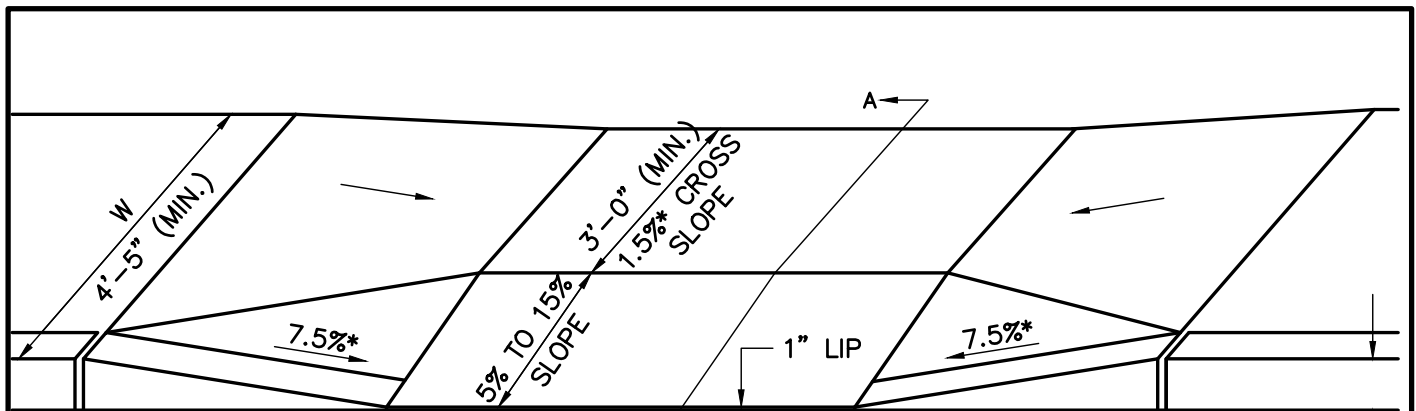

HIGH SIDE TRANSITION (SEE DETAIL RS.14)      RESIDENTIAL DRIVEWAYS: 16'-0" (NEW) OR VARIES TO MEET EXISTING      LOW SIDE TRANSITION (6'-6" MIN.)      6" CURB REVEAL

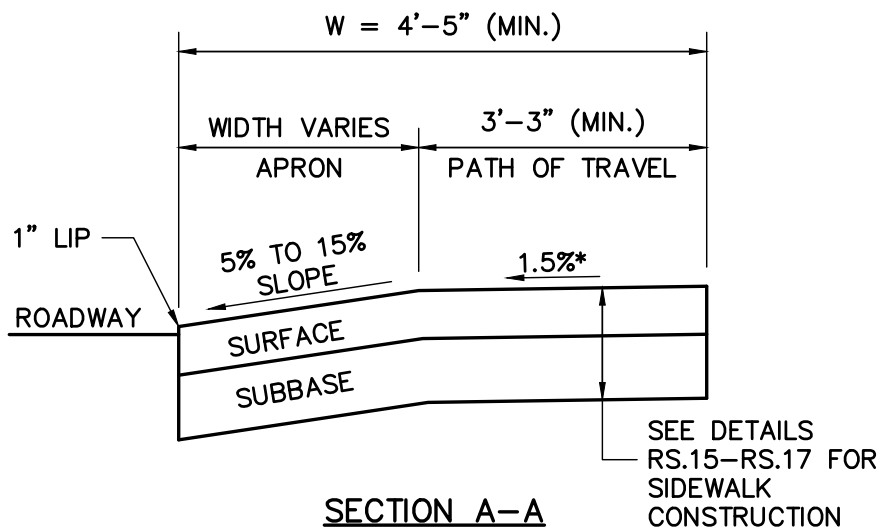

W = SIDEWALK WIDTH

\* = TOLERANCE FOR CONSTRUCTION ±0.5%

DRIVEWAYS SHALL BE CONSTRUCTED IN CONFORMANCE WITH THE CURRENT REGULATIONS OF THE ARCHITECTURAL ACCESS BOARD, THE AMERICANS WITH DISABILITIES ACT AND THE CURRENT MassDOT CONSTRUCTION STANDARDS.

UNLESS OTHERWISE NOTED, CONSTRUCTION METHODS, MATERIAL REQUIREMENTS AND METHOD OF MEASUREMENT SHALL BE IN ACCORDANCE WITH THE LATEST EDITION OF THE MASSACHUSETTS DEPARTMENT OF TRANSPORTATION (MassDOT) STANDARD SPECIFICATIONS.

ALSO REFERENCE CURRENT MassDOT CONSTRUCTION STANDARD DETAILS.



**DEDHAM DPW  
DESIGN & CONSTRUCTION STANDARDS**

**CEMENT CONCRETE SIDEWALK THROUGH DRIVEWAYS  
NO CURB RETURNS**

SCALE: NTS	DATE OF ISSUE: AUGUST 2015
REVISED:	
DETAIL NUMBER: RS.11	

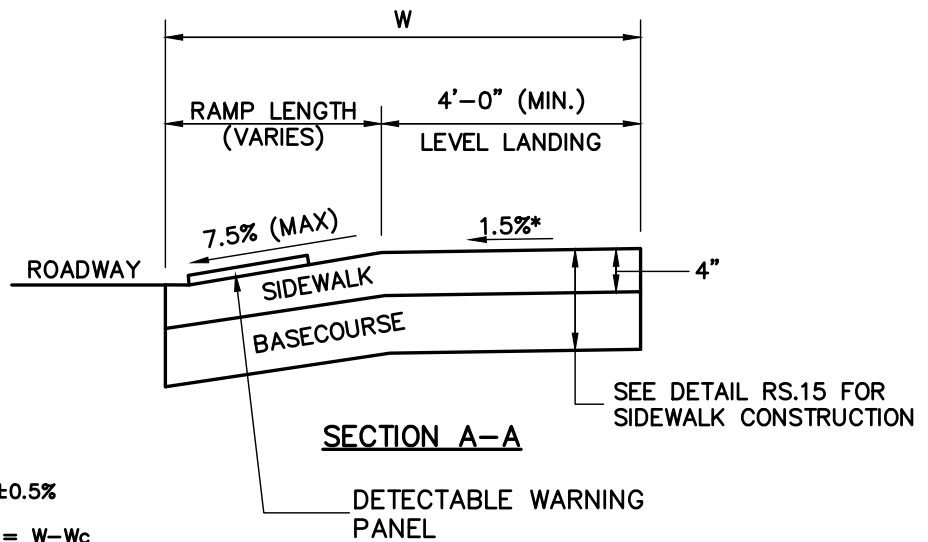
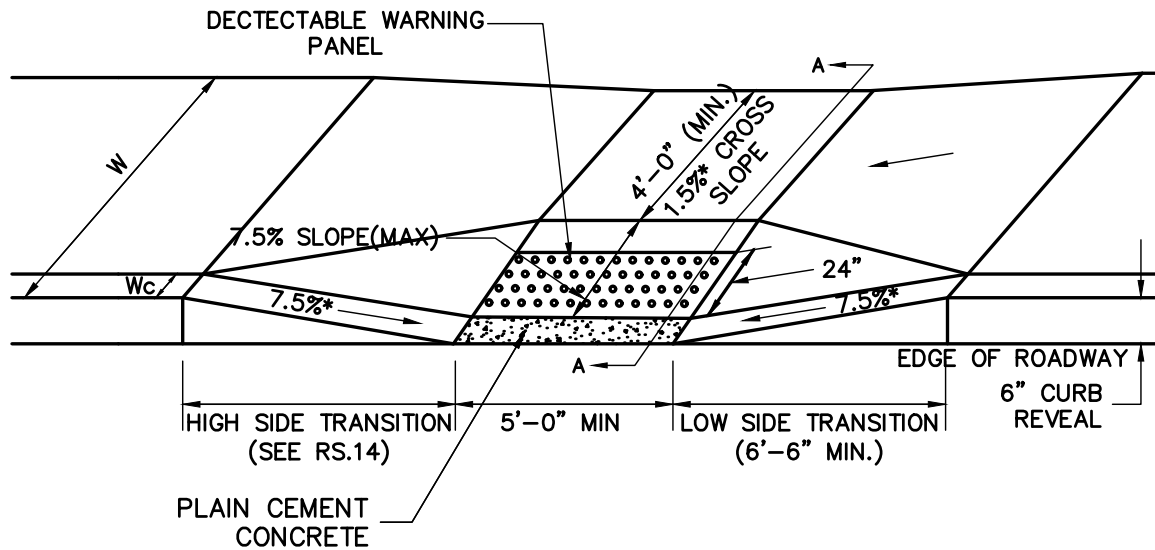

**LEGEND**

- W = SIDEWALK WIDTH
- W<sub>c</sub> = CURB WIDTH
- \* = TOLERANCE FOR CONSTRUCTION ±0.5%
- USABLE SIDEWALK WIDTH PER AAB = W - W<sub>c</sub>
- USABLE SIDEWALK WIDTH PER AAB IS NOT TO BE LESS THAN 4'-0"

SIDEWALKS SHALL BE CONSTRUCTED IN CONFORMANCE WITH THE CURRENT REGULATIONS OF THE ARCHITECTURAL ACCESS BOARD, THE AMERICANS WITH DISABILITIES ACT AND THE CURRENT MassDOT CONSTRUCTION STANDARDS.

UNLESS OTHERWISE NOTED, CONSTRUCTION METHODS, MATERIAL REQUIREMENTS AND METHOD OF MEASUREMENT SHALL BE IN ACCORDANCE WITH THE LATEST EDITION OF THE MASSACHUSETTS DEPARTMENT OF TRANSPORTATION (MassDOT) STANDARD SPECIFICATIONS.

ALSO REFERENCE CURRENT MassDOT CONSTRUCTION STANDARD DETAILS.



**DEDHAM DPW  
DESIGN & CONSTRUCTION STANDARDS**

**CONCRETE WHEELCHAIR RAMPS**

SCALE: NTS      DATE OF ISSUE:  
AUGUST 2015

REVISED:

DETAIL NUMBER:  
RS.12

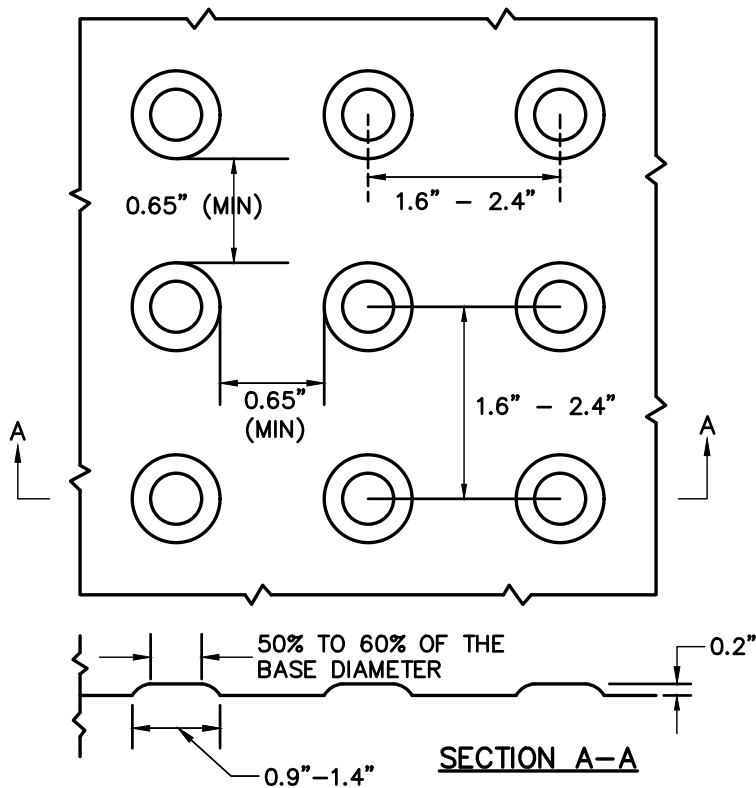
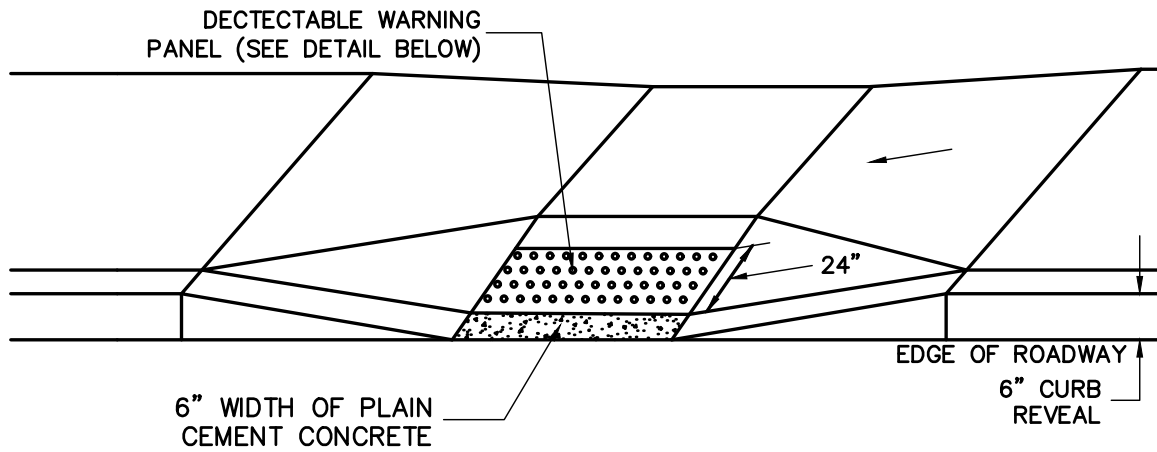

PANELS MAY BE CONCRETE PRECAST OR CAST IN PLACE OR OTHER SUITABLE MATERIAL PERMANENTLY APPLIED TO THE RAMP. DETECTABLE WARNING SURFACES SHALL CONTRAST VISUALLY WITH ADJACENT WALKING SURFACES EITHER LIGHT-ON-DARK OR DARK-ON-LIGHT.

UNLESS OTHERWISE NOTED, CONSTRUCTION METHODS, MATERIAL REQUIREMENTS AND METHOD OF MEASUREMENT SHALL BE IN ACCORDANCE WITH THE LATEST EDITION OF THE MASSACHUSETTS DEPARTMENT OF TRANSPORTATION (MassDOT) STANDARD SPECIFICATIONS.

ALSO REFERENCE CURRENT MassDOT CONSTRUCTION STANDARD DETAILS.



**DEDHAM DPW  
DESIGN & CONSTRUCTION STANDARDS**

DETECTABLE WARNING PANELS  
FOR WHEELCHAIR RAMPS

SCALE: NTS	DATE OF ISSUE: AUGUST 2015
---------------	-------------------------------

REVISED:

DETAIL NUMBER: RS.13
-------------------------

ROADWAY PROFILE GRADE (%)	*HIGH SIDE TRANSITION LENGTH
0	6'-6"
>0 TO 1	7'-8"
>1 TO 2	9'-0"
>2 TO 3	11'-0"
>3 TO 4	14'-0"
>4	15'-0" (MAX)

NOTE:

\* BASED ON DESIGN SLOPE OF 7.5% AND A CURB REVEAL OF 6"

UNLESS OTHERWISE NOTED, CONSTRUCTION METHODS, MATERIAL REQUIREMENTS AND METHOD OF MEASUREMENT SHALL BE IN ACCORDANCE WITH THE LATEST EDITION OF THE MASSACHUSETTS DEPARTMENT OF TRANSPORTATION (MassDOT) STANDARD SPECIFICATIONS.

ALSO REFERENCE CURRENT MassDOT CONSTRUCTION STANDARD DETAILS.



**DEDHAM DPW  
DESIGN & CONSTRUCTION STANDARDS**

CURB TRANSITION LENGTH  
FOR WHEELCHAIR RAMPS

SCALE: DATE OF ISSUE:  
NTS AUGUST 2015

REVISED:

DETAIL NUMBER:  
RS.14

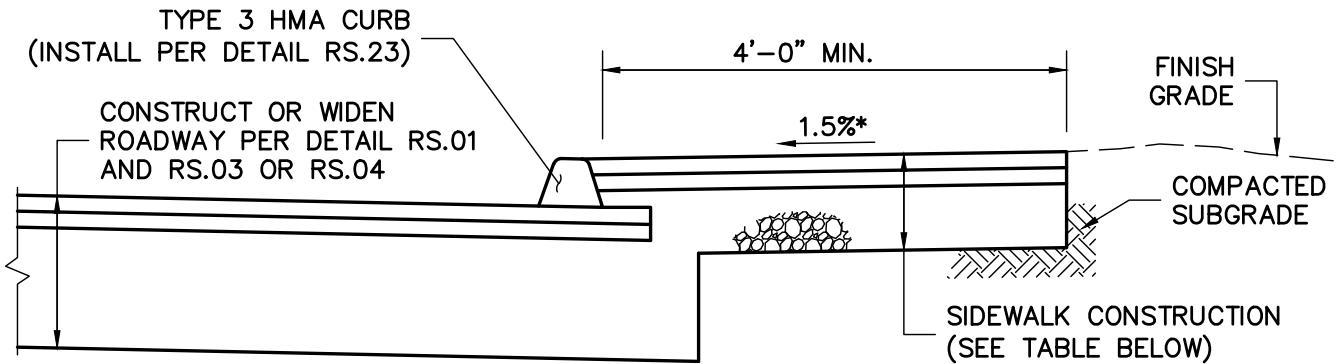
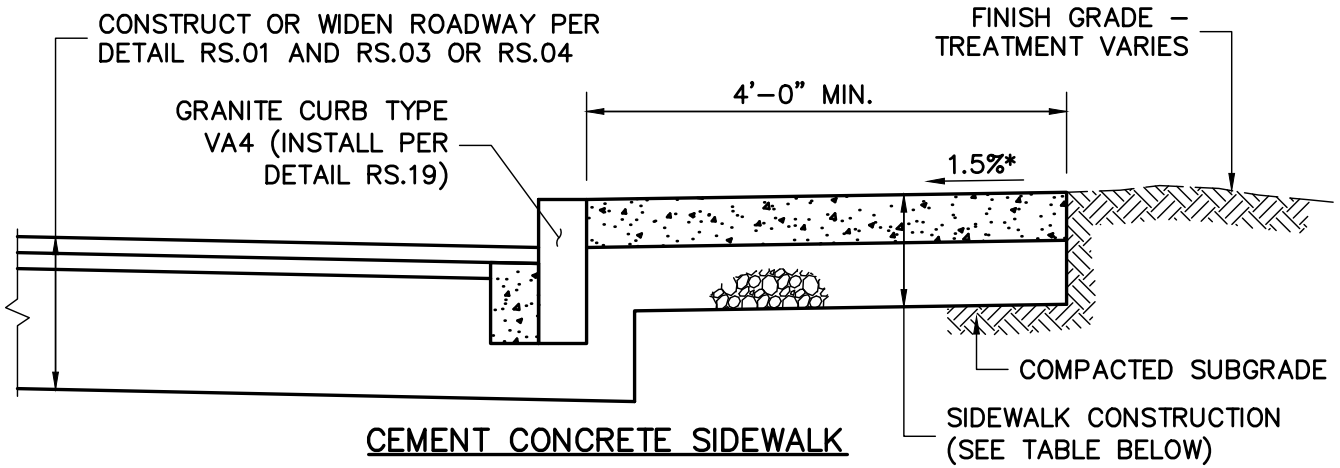

NOTE: GRANITE CURB MAY BE USED WITH HMA SIDEWALK

**HOT MIX ASPHALT SIDEWALK**

SIDEWALK CONSTRUCTION		
	CEMENT CONCRETE CONSTRUCTION	HOT MIX ASPHALT CONSTRUCTION
SURFACE:	4" CEMENT CONCRETE (6" AT DRIVEWAYS) (4000 PSI, 3/4", 610)	2.5" HOT MIX ASPHALT (1.25" TOP COURSE MATERIAL OVER 1.25" BINDER COURSE MATERIAL)
SUBBASE:	8" GRAVEL BORROW (TYPE "B")	8" GRAVEL BORROW (TYPE "B")

\* - TOLERANCE FOR CONSTRUCTION ±0.5%

UNLESS OTHERWISE NOTED, CONSTRUCTION METHODS, MATERIAL REQUIREMENTS AND METHOD OF MEASUREMENT SHALL BE IN ACCORDANCE WITH THE LATEST EDITION OF THE MASSACHUSETTS DEPARTMENT OF TRANSPORTATION (MassDOT) STANDARD SPECIFICATIONS.

ALSO REFERENCE CURRENT MassDOT CONSTRUCTION STANDARD DETAILS.



**DEDHAM DPW  
DESIGN & CONSTRUCTION STANDARDS**

HOT MIX ASPHALT OR CEMENT CONCRETE SIDEWALK

SCALE: NTS      DATE OF ISSUE: AUGUST 2015

REVISED:

DETAIL NUMBER: RS.15

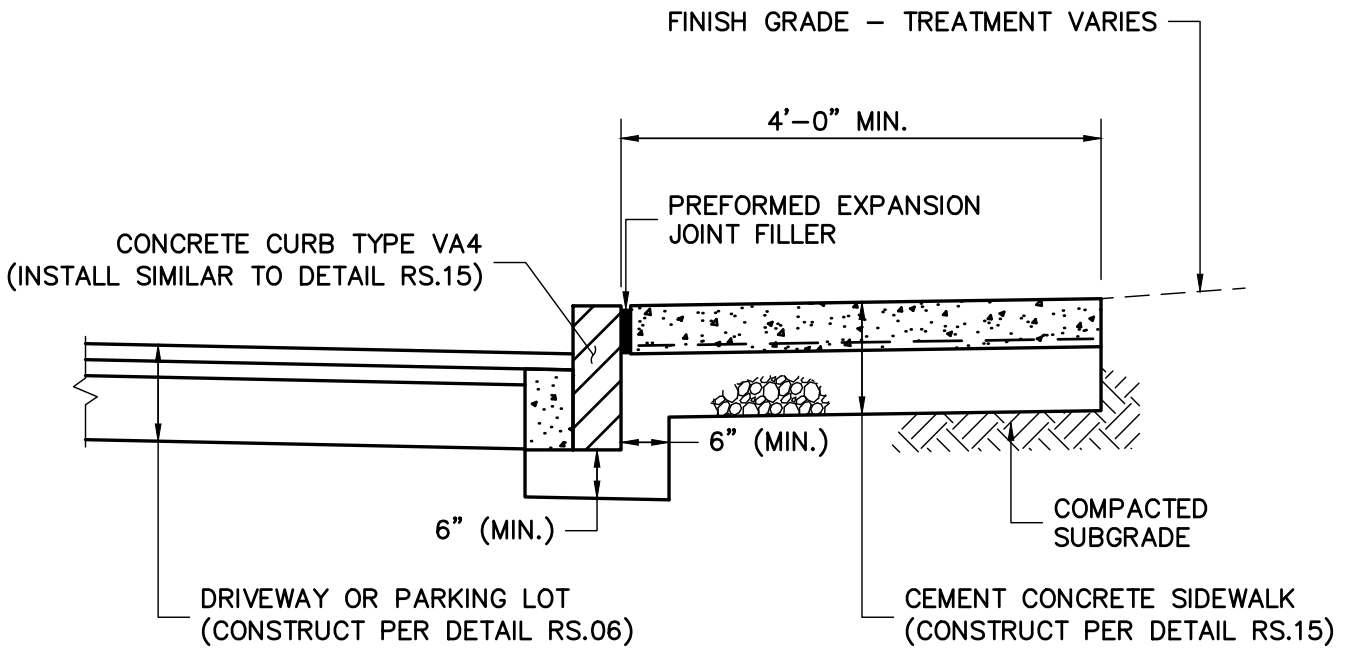

NOTE: PRECAST CONCRETE CURB SHALL NOT BE USED ON ANY PUBLIC STREET OR WAY. PRECAST CONCRETE CURB MAY BE USED ON PRIVATE WAYS, DRIVEWAYS AND IN PARKING LOTS.

UNLESS OTHERWISE NOTED, CONSTRUCTION METHODS, MATERIAL REQUIREMENTS AND METHOD OF MEASUREMENT SHALL BE IN ACCORDANCE WITH THE LATEST EDITION OF THE MASSACHUSETTS DEPARTMENT OF TRANSPORTATION (MassDOT) STANDARD SPECIFICATIONS.

ALSO REFERENCE CURRENT MassDOT CONSTRUCTION STANDARD DETAILS.



**DEDHAM DPW  
DESIGN & CONSTRUCTION STANDARDS**

PRECAST CONCRETE CURB & SIDEWALK

SCALE: NTS	DATE OF ISSUE: AUGUST 2015
---------------	-------------------------------

REVISED:

DETAIL NUMBER: RS.16
-------------------------



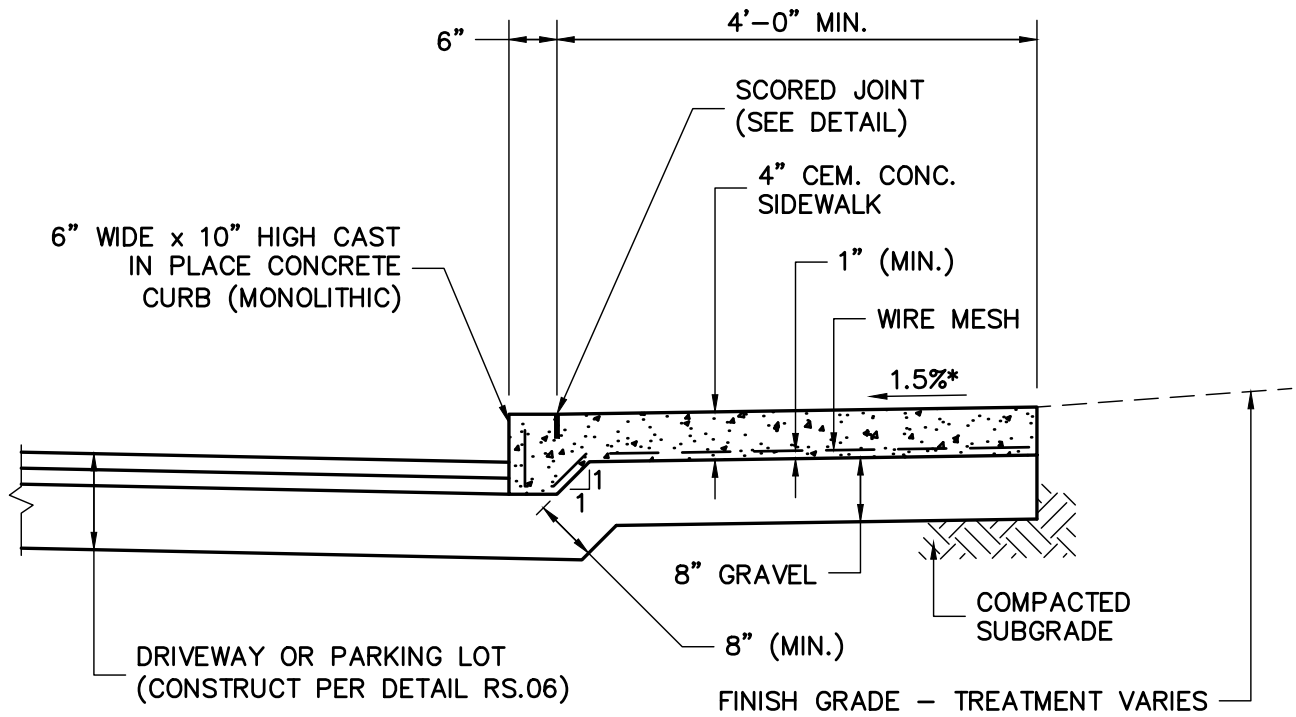

**SECTION VIEW**

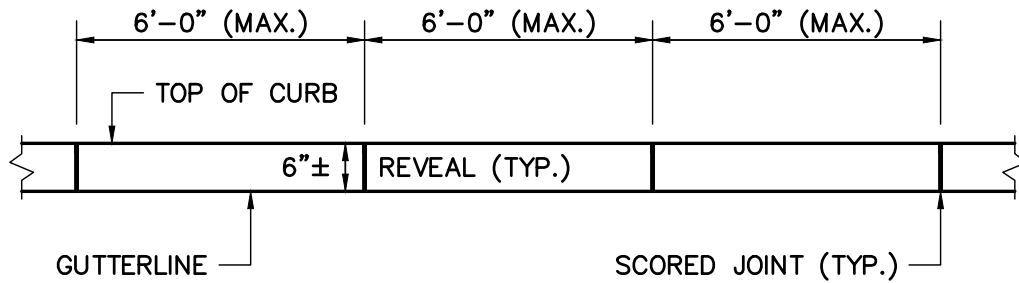

**SCORED JOINT DETAIL FRONT VIEW**

NOTE: MONOLITHIC CONCRETE CURB SHALL NOT BE USED ON ANY PUBLIC STREET OR WAY. MONOLITHIC CONCRETE CURB MAY BE USED ON PRIVATE WAYS, DRIVEWAYS AND IN PARKING LOTS.

\* - TOLERANCE FOR CONSTRUCTION  $\pm 0.5\%$

UNLESS OTHERWISE NOTED, CONSTRUCTION METHODS, MATERIAL REQUIREMENTS AND METHOD OF MEASUREMENT SHALL BE IN ACCORDANCE WITH THE LATEST EDITION OF THE MASSACHUSETTS DEPARTMENT OF TRANSPORTATION (MassDOT) STANDARD SPECIFICATIONS.

ALSO REFERENCE CURRENT MassDOT CONSTRUCTION STANDARD DETAILS.



**DEDHAM DPW  
DESIGN & CONSTRUCTION STANDARDS**

CAST IN PLACE CONCRETE CURB & SIDEWALK

SCALE: NTS      DATE OF ISSUE: AUGUST 2015

REVISED:

DETAIL NUMBER: RS.17

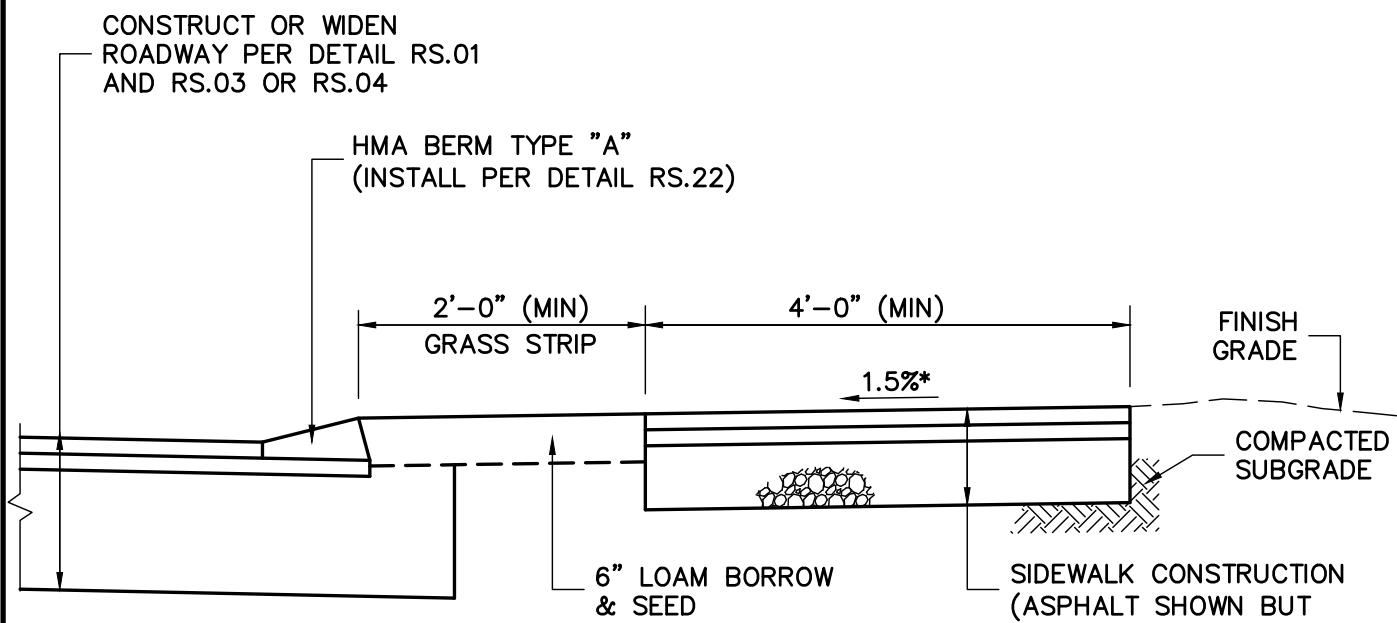

NOTE: GRANITE CURB OR HMA BERM TYPE 3 MAY BE USED (INSTALL PER DETAIL RS.19, RS.20, OR RS.23)

	CEMENT CONCRETE CONSTRUCTION	HOT MIX ASPHALT CONSTRUCTION
SURFACE:	4" CEMENT CONCRETE (4000 PSI, 3/4", 610)	2.5" HOT MIX ASPHALT (1.25" TOP COURSE MATERIAL OVER 1.25" BINDER COURSE MATERIAL)
BASECOURSE:	8" GRAVEL BORROW (TYPE "B")	8" GRAVEL BORROW (TYPE "B")

\* - TOLERANCE FOR CONSTRUCTION ±0.5%

UNLESS OTHERWISE NOTED, CONSTRUCTION METHODS, MATERIAL REQUIREMENTS AND METHOD OF MEASUREMENT SHALL BE IN ACCORDANCE WITH THE LATEST EDITION OF THE MASSACHUSETTS DEPARTMENT OF TRANSPORTATION (MassDOT) STANDARD SPECIFICATIONS.

ALSO REFERENCE CURRENT MassDOT CONSTRUCTION STANDARD DETAILS.



**DEDHAM DPW  
DESIGN & CONSTRUCTION STANDARDS**

SIDEWALK WITH GRASS STRIP

SCALE: NTS	DATE OF ISSUE: AUGUST 2015
REVISED:	
DETAIL NUMBER: RS.18	

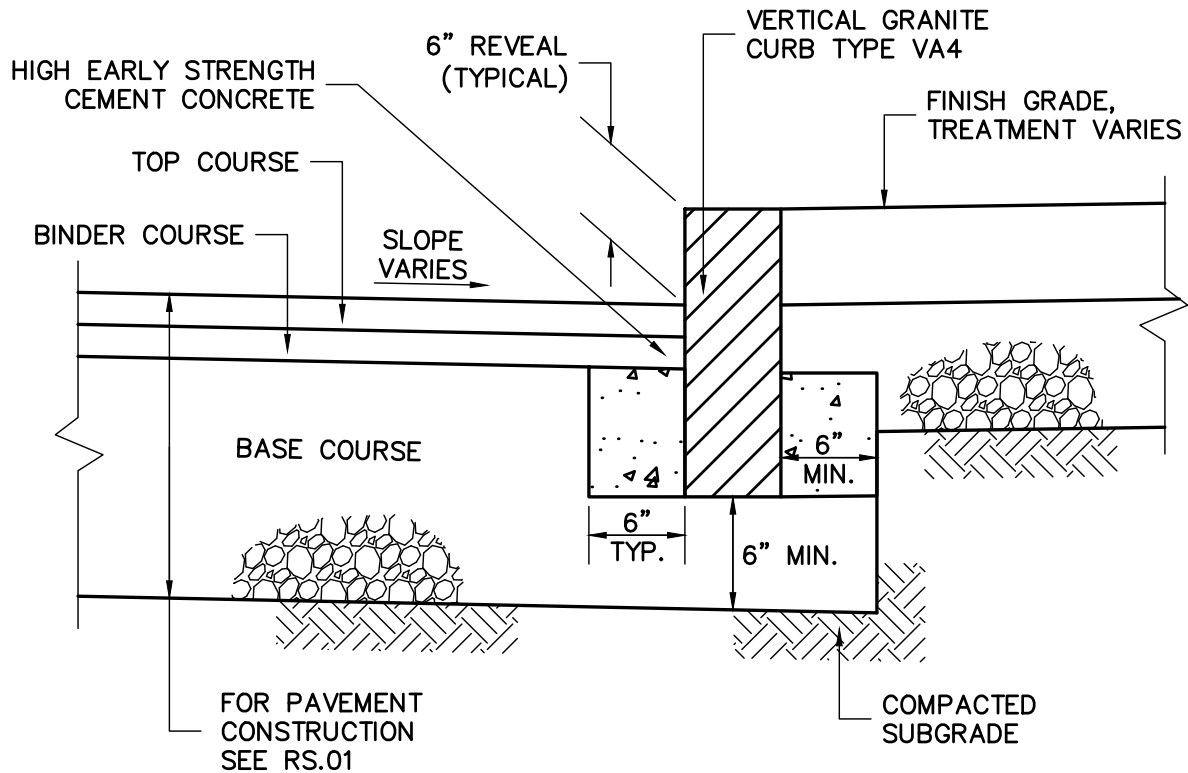

**NOTES:**

1. CEMENT CONCRETE TO BE USED IF CURB IS SET AFTER BASE AND/OR BINDER IS IN PLACE. PAYMENT FOR CEMENT CONCRETE SHALL BE INCLUDED IN THE PRICE PER LINEAR FOOT OF CURB.
2. JOINTS SHALL BE FILLED AND POINTED IN ACCORDANCE WITH MASSDOT SPECS.

UNLESS OTHERWISE NOTED, CONSTRUCTION METHODS, MATERIAL REQUIREMENTS AND METHOD OF MEASUREMENT SHALL BE IN ACCORDANCE WITH THE LATEST EDITION OF THE MASSACHUSETTS DEPARTMENT OF TRANSPORTATION (MassDOT) STANDARD SPECIFICATIONS.

ALSO REFERENCE CURRENT MassDOT CONSTRUCTION STANDARD DETAILS.



**DEDHAM DPW  
DESIGN & CONSTRUCTION STANDARDS**

VERTICAL GRANITE CURB  
TYPE VA4

SCALE: NTS	DATE OF ISSUE: AUGUST 2015
---------------	-------------------------------

REVISED: JANUARY 2017
--------------------------

DETAIL NUMBER: RS.19
-------------------------

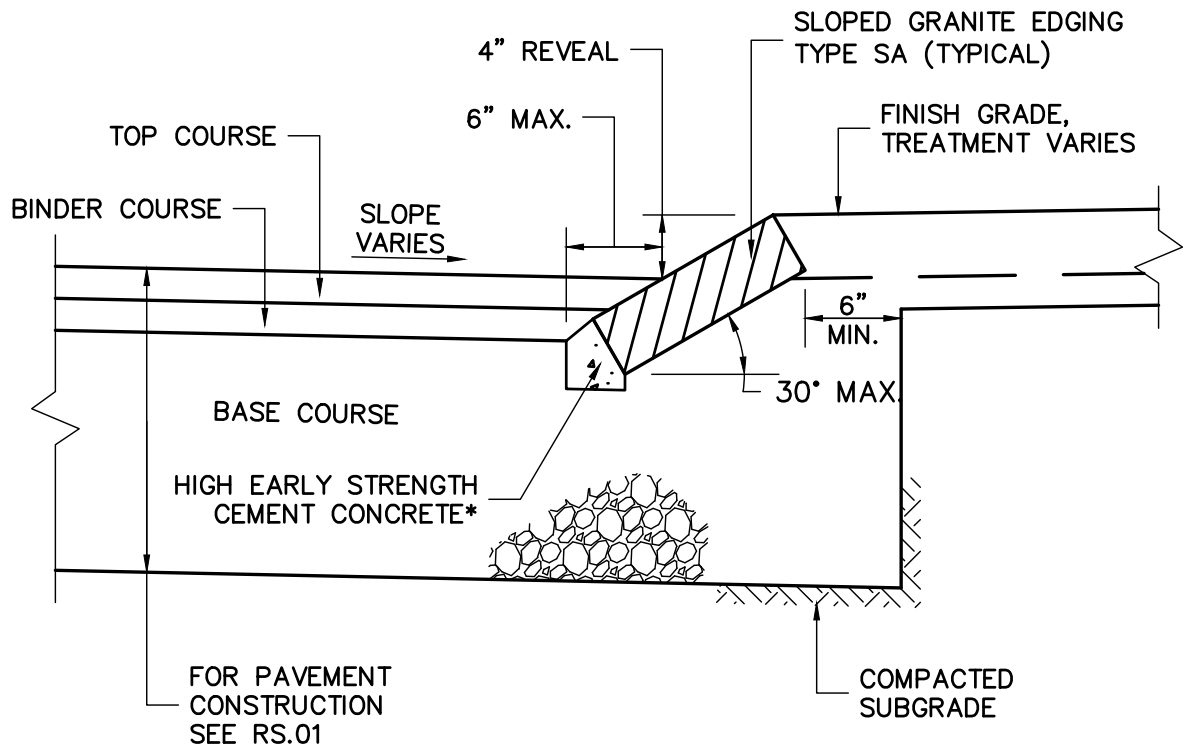

\* - GRAVEL BASECOURSE TO BE PLACED PRIOR TO SETTING EDGING. PAYMENT FOR CEMENT CONCRETE SHALL BE INCLUDED IN THE PRICE PER LINEAR FOOT OF EDGING.

UNLESS OTHERWISE NOTED, CONSTRUCTION METHODS, MATERIAL REQUIREMENTS AND METHOD OF MEASUREMENT SHALL BE IN ACCORDANCE WITH THE LATEST EDITION OF THE MASSACHUSETTS DEPARTMENT OF TRANSPORTATION (MassDOT) STANDARD SPECIFICATIONS.

ALSO REFERENCE CURRENT MassDOT CONSTRUCTION STANDARD DETAILS.



**DEDHAM DPW  
DESIGN & CONSTRUCTION STANDARDS**

**SLOPED GRANITE EDGING**

SCALE: NTS	DATE OF ISSUE: AUGUST 2015
---------------	-------------------------------

REVISED: JANUARY 2017
--------------------------

DETAIL NUMBER: RS.20
-------------------------

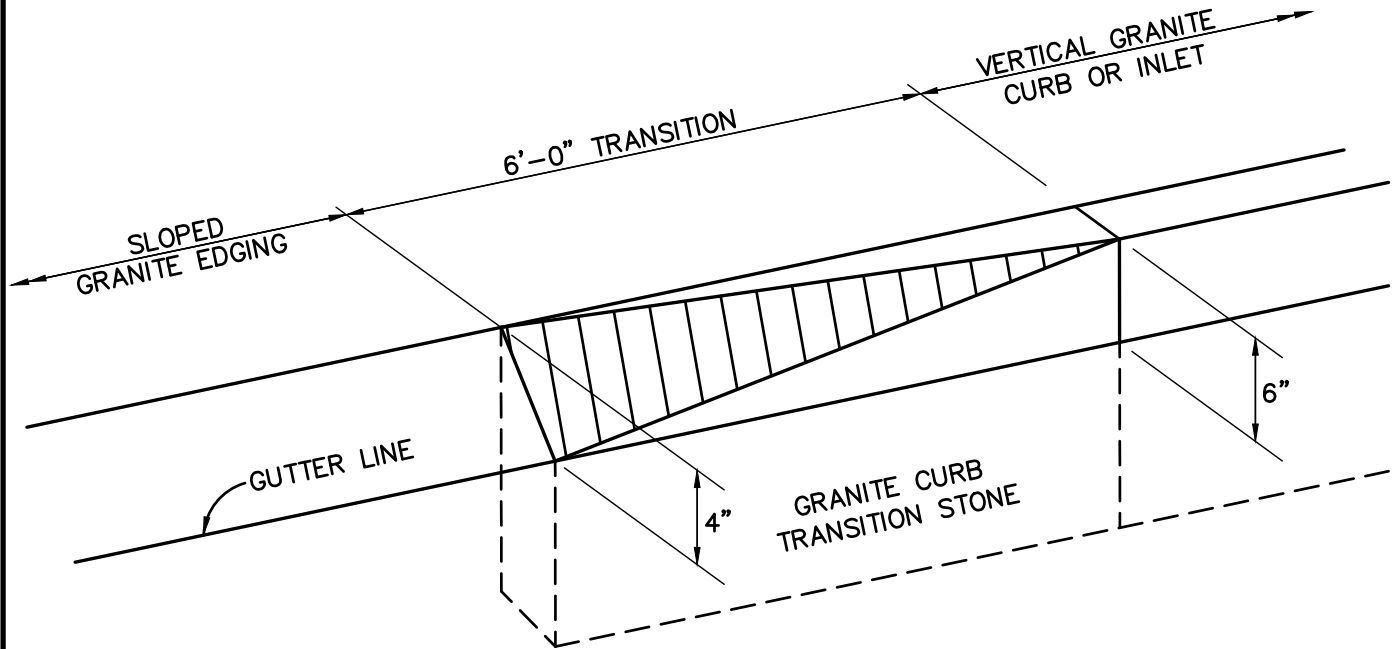

UNLESS OTHERWISE NOTED, CONSTRUCTION METHODS, MATERIAL REQUIREMENTS AND METHOD OF MEASUREMENT SHALL BE IN ACCORDANCE WITH THE LATEST EDITION OF THE MASSACHUSETTS DEPARTMENT OF TRANSPORTATION (MassDOT) STANDARD SPECIFICATIONS.

ALSO REFERENCE CURRENT MassDOT CONSTRUCTION STANDARD DETAILS.



**DEDHAM DPW  
DESIGN & CONSTRUCTION STANDARDS**

GRANITE CURB TO SLOPED EDGING TRANSITION

SCALE: NTS	DATE OF ISSUE: AUGUST 2015
---------------	-------------------------------

REVISED:

DETAIL NUMBER: RS.21
-------------------------

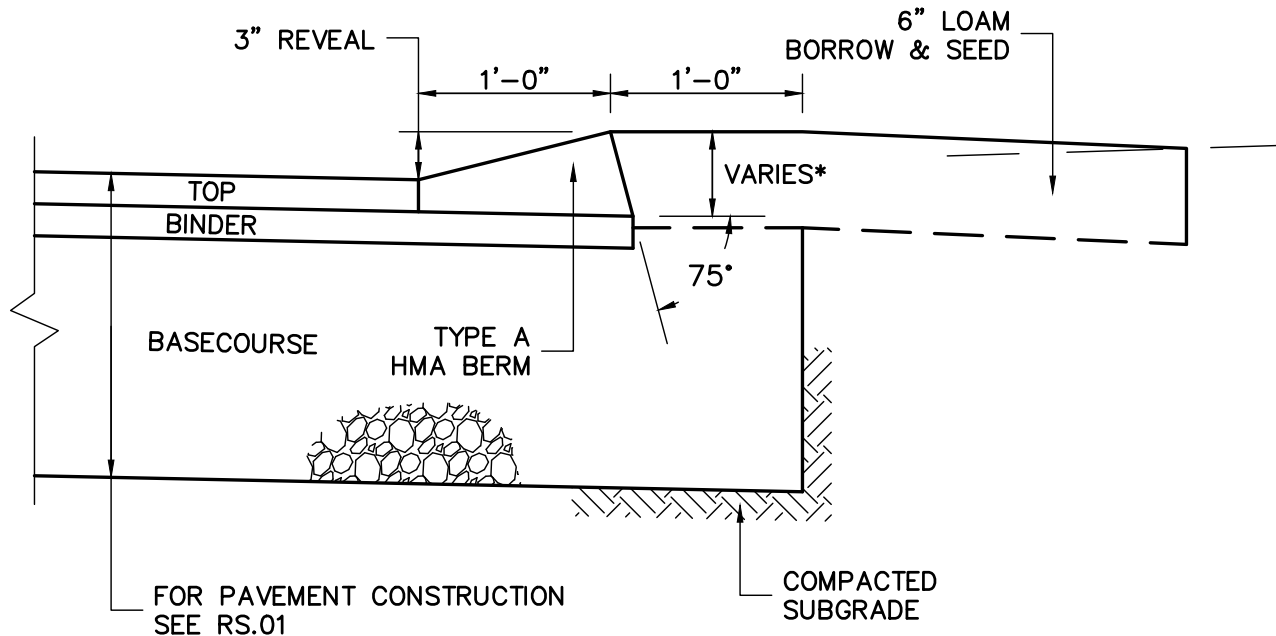

\* - DEPTH VARIES WITH TOP COURSE THICKNESS AND ROADWAY CROSS SLOPE

NOTE: HOT MIX ASPHALT BERM - TYPE "A" NOT ACCEPTABLE ABUTTING SIDEWALKS.

UNLESS OTHERWISE NOTED, CONSTRUCTION METHODS, MATERIAL REQUIREMENTS AND METHOD OF MEASUREMENT SHALL BE IN ACCORDANCE WITH THE LATEST EDITION OF THE MASSACHUSETTS DEPARTMENT OF TRANSPORTATION (MassDOT) STANDARD SPECIFICATIONS.

ALSO REFERENCE CURRENT MassDOT CONSTRUCTION STANDARD DETAILS.



**DEDHAM DPW  
DESIGN & CONSTRUCTION STANDARDS**

HOT MIX ASPHALT BERM - TYPE "A"

SCALE: DATE OF ISSUE:  
NTS AUGUST 2015

REVISED:

DETAIL NUMBER:  
RS.22

TYPE 3 HMA CURB  
(SEE DETAIL BELOW)

ASPHALT SIDEWALK  
(UNLESS OTHERWISE  
SPECIFIED BY DEDHAM DPW)

APPLY TACK COAT OF RS-1 EMULSION TO  
SURFACE OF EXISTING PAVEMENT PRIOR TO THE  
PLACEMENT OF THE NEW HOT MIX ASPHALT CURB

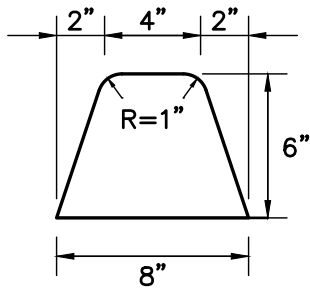
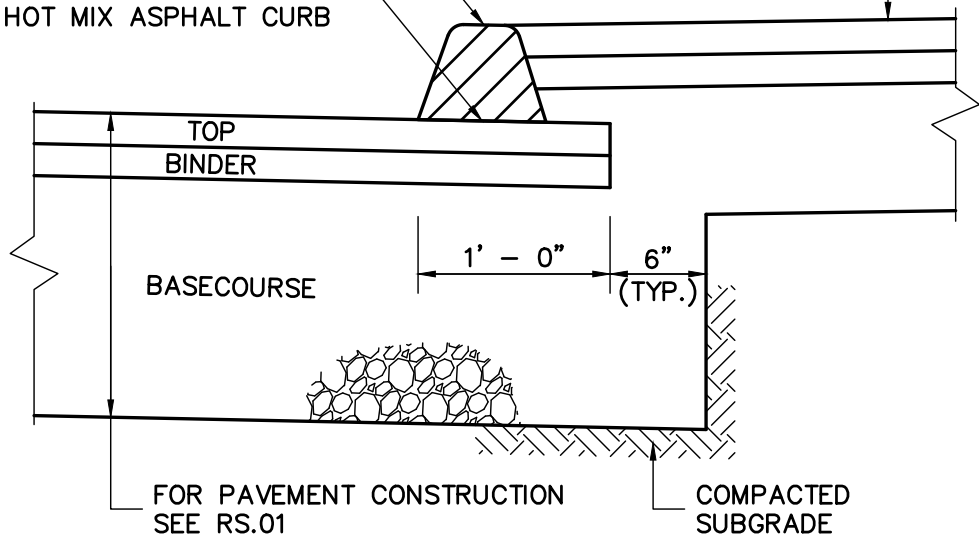

UNLESS OTHERWISE NOTED, CONSTRUCTION METHODS, MATERIAL REQUIREMENTS AND METHOD OF MEASUREMENT SHALL BE IN ACCORDANCE WITH THE LATEST EDITION OF THE MASSACHUSETTS DEPARTMENT OF TRANSPORTATION (MassDOT) STANDARD SPECIFICATIONS.

ALSO REFERENCE CURRENT MassDOT CONSTRUCTION STANDARD DETAILS.



**DEDHAM DPW  
DESIGN & CONSTRUCTION STANDARDS**

HOT MIX ASPHALT CURB – TYPE 3

SCALE: NTS  
DATE OF ISSUE: AUGUST 2015

REVISED:

DETAIL NUMBER:  
RS.23

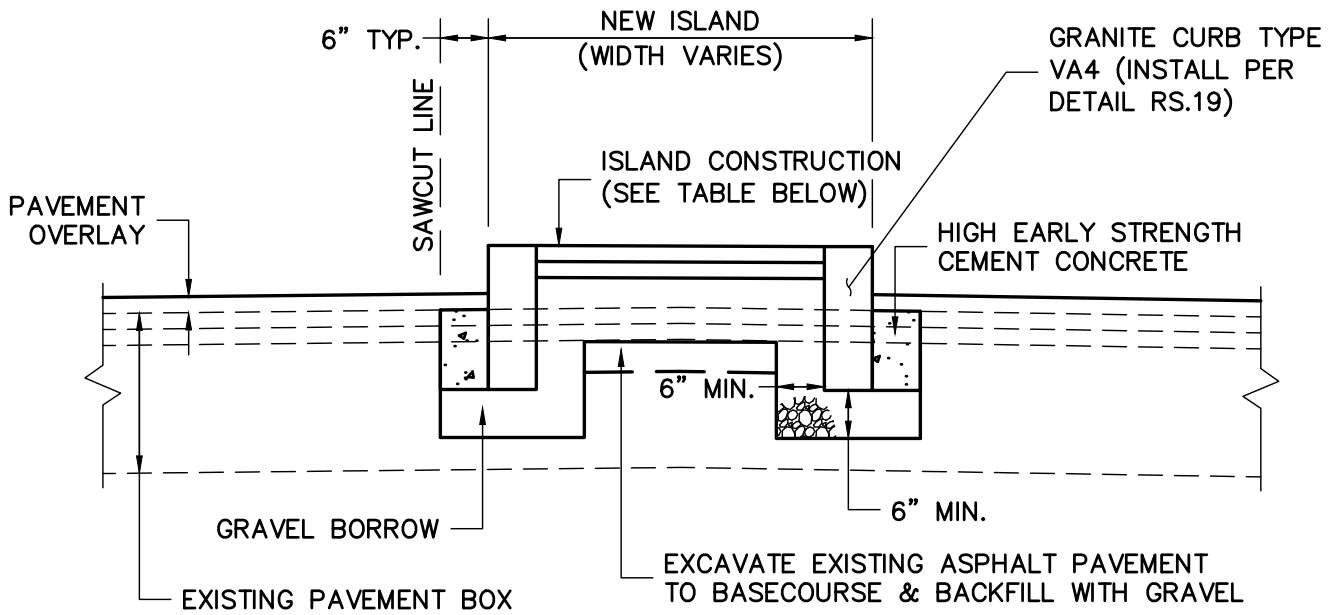

ISLAND CONSTRUCTION		
	CEMENT CONCRETE CONSTRUCTION	HOT MIX ASPHALT
SURFACE:	4" CEMENT CONCRETE (4000 PSI, 3/4", 610)	2.5" HOT MIX ASPHALT (1.25" TOP COURSE MATERIAL OVER 1.25" BINDER COURSE MATERIAL)
BASECOURSE:	8" GRAVEL BORROW (TYPE "B")	8" GRAVEL BORROW (TYPE "B")

UNLESS OTHERWISE NOTED, CONSTRUCTION METHODS, MATERIAL REQUIREMENTS AND METHOD OF MEASUREMENT SHALL BE IN ACCORDANCE WITH THE LATEST EDITION OF THE MASSACHUSETTS DEPARTMENT OF TRANSPORTATION (MassDOT) STANDARD SPECIFICATIONS.

ALSO REFERENCE CURRENT MassDOT CONSTRUCTION STANDARD DETAILS.



**DEDHAM DPW  
DESIGN & CONSTRUCTION STANDARDS**

TRAFFIC ISLAND – VERTICAL CURBING

SCALE: NTS	DATE OF ISSUE: AUGUST 2015
---------------	-------------------------------

REVISED:

DETAIL NUMBER: RS.24
-------------------------



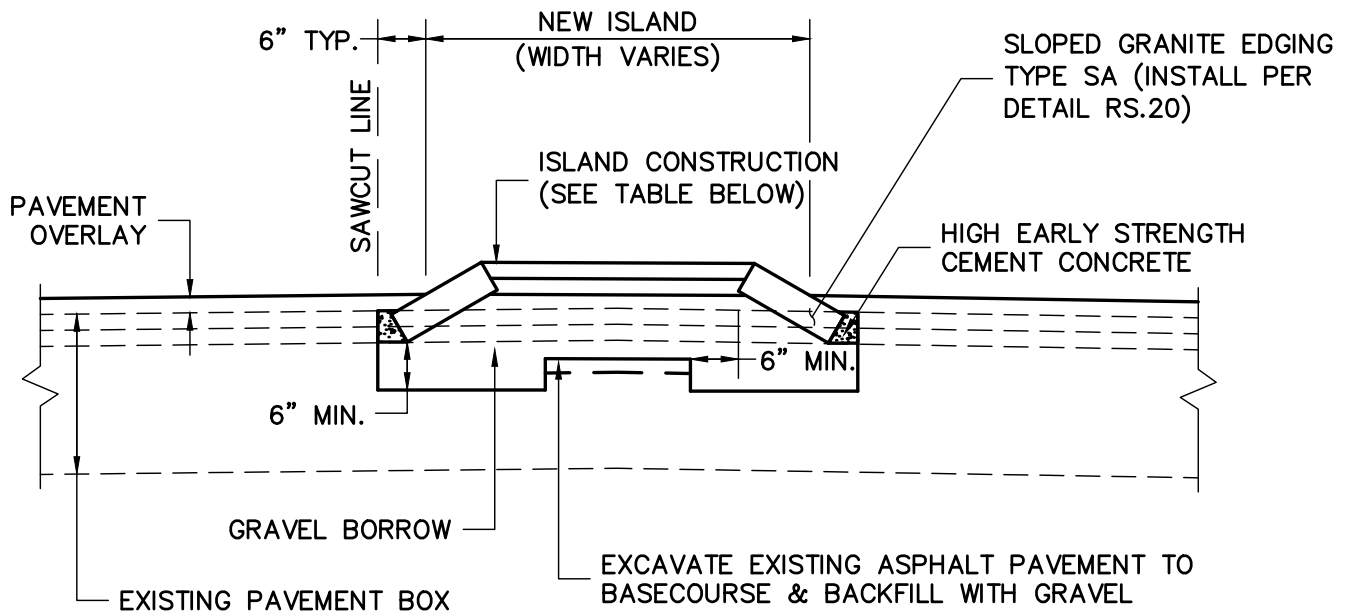

### ISLAND CONSTRUCTION

	CEMENT CONCRETE CONSTRUCTION	HOT MIX ASPHALT
SURFACE:	4" CEMENT CONCRETE (4000 PSI, 3/4", 610)	2.5" HOT MIX ASPHALT (1.25" TOP COURSE MATERIAL OVER 1.25" BINDER COURSE MATERIAL)
BASECOURSE:	8" GRAVEL BORROW (TYPE "B")	8" GRAVEL BORROW (TYPE "B")

UNLESS OTHERWISE NOTED, CONSTRUCTION METHODS, MATERIAL REQUIREMENTS AND METHOD OF MEASUREMENT SHALL BE IN ACCORDANCE WITH THE LATEST EDITION OF THE MASSACHUSETTS DEPARTMENT OF TRANSPORTATION (MassDOT) STANDARD SPECIFICATIONS.

ALSO REFERENCE CURRENT MassDOT CONSTRUCTION STANDARD DETAILS.



## DEDHAM DPW DESIGN & CONSTRUCTION STANDARDS

TRAFFIC ISLAND – SLOPED EDGING

SCALE: NTS  
DATE OF ISSUE: AUGUST 2015

REVISED:

DETAIL NUMBER:  
RS.25

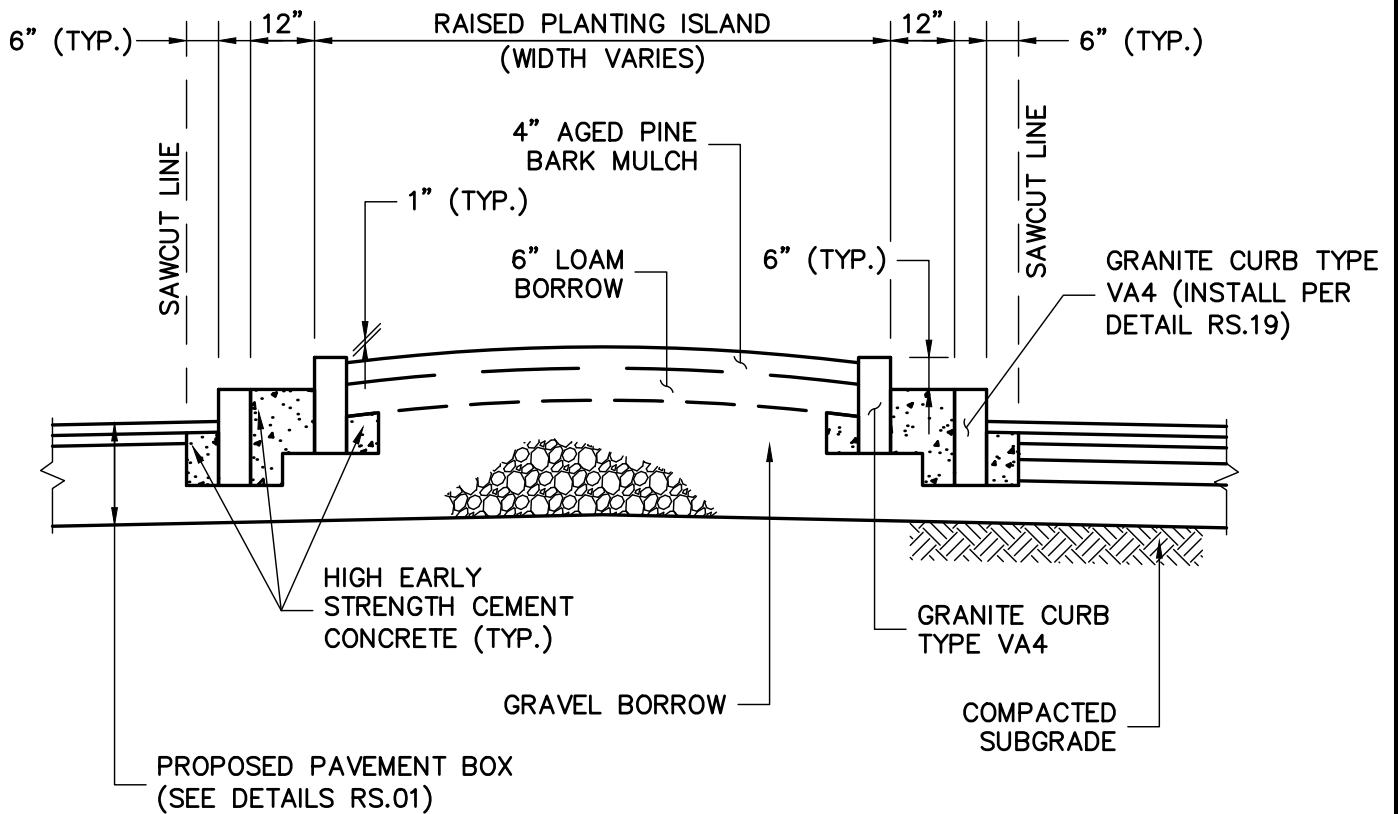

UNLESS OTHERWISE NOTED, CONSTRUCTION METHODS, MATERIAL REQUIREMENTS AND METHOD OF MEASUREMENT SHALL BE IN ACCORDANCE WITH THE LATEST EDITION OF THE MASSACHUSETTS DEPARTMENT OF TRANSPORTATION (MassDOT) STANDARD SPECIFICATIONS.

ALSO REFERENCE CURRENT MassDOT CONSTRUCTION STANDARD DETAILS.



**DEDHAM DPW  
DESIGN & CONSTRUCTION STANDARDS**

**RAISED PLANTING ISLAND**

SCALE: NTS      DATE OF ISSUE: AUGUST 2015

REVISED:

DETAIL NUMBER: RS.26

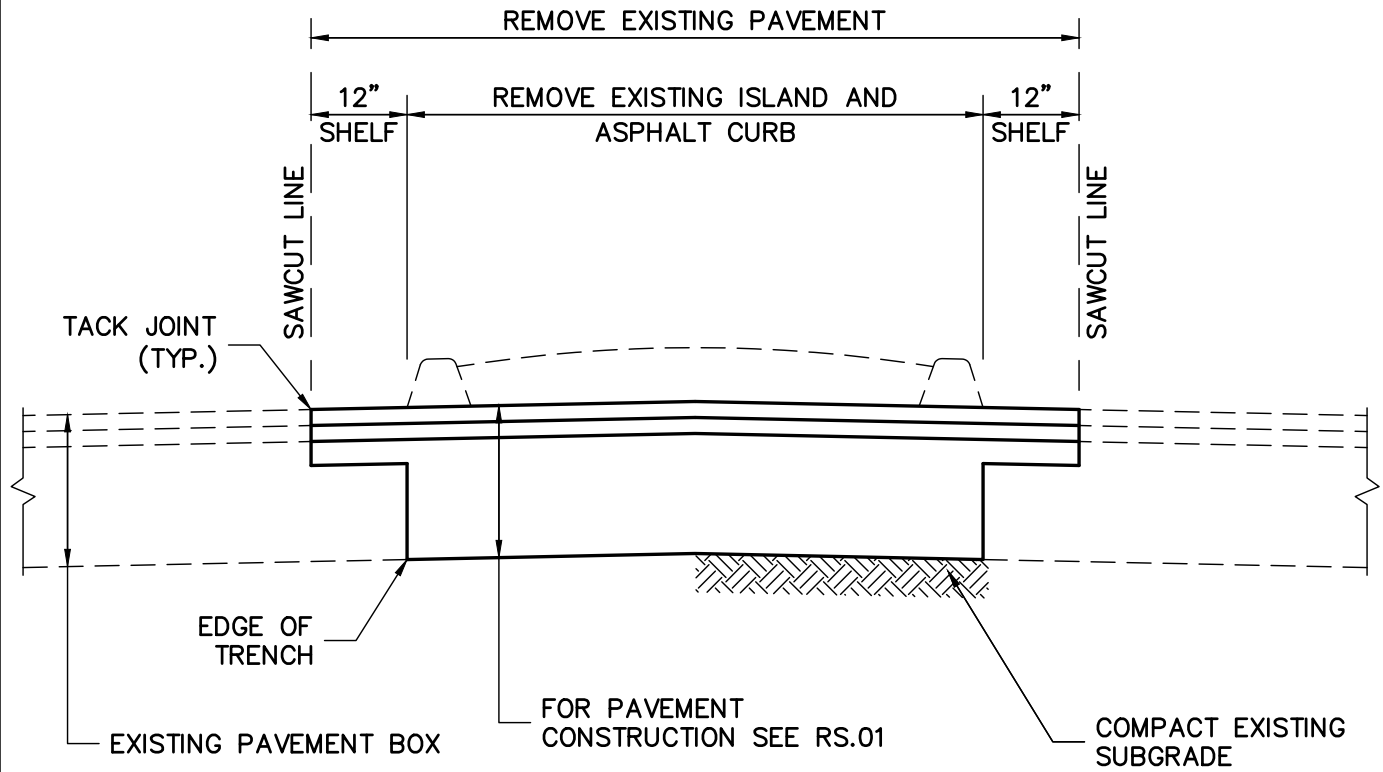

UNLESS OTHERWISE NOTED, CONSTRUCTION METHODS, MATERIAL REQUIREMENTS AND METHOD OF MEASUREMENT SHALL BE IN ACCORDANCE WITH THE LATEST EDITION OF THE MASSACHUSETTS DEPARTMENT OF TRANSPORTATION (MassDOT) STANDARD SPECIFICATIONS.

ALSO REFERENCE CURRENT MassDOT CONSTRUCTION STANDARD DETAILS.



**DEDHAM DPW  
DESIGN & CONSTRUCTION STANDARDS**

ISLAND REMOVAL

SCALE: DATE OF ISSUE:  
NTS AUGUST 2015

REVISED:

DETAIL NUMBER:  
RS.27

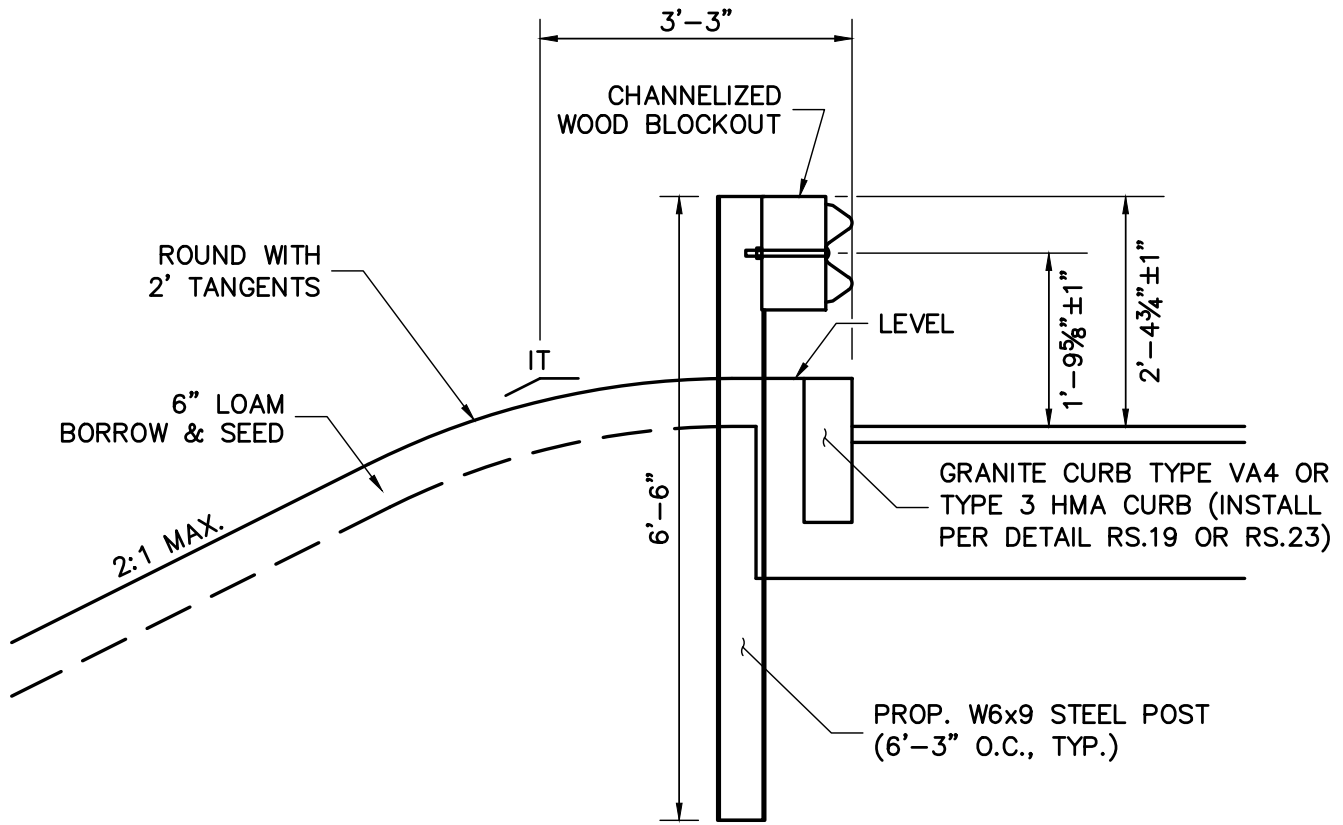

**STEEL POST SHOWN**

**NOTES:**

1. ALL GUARDRAIL SHALL BE INSTALLED IN ACCORDANCE WITH THE LATEST MassDOT CONSTRUCTION STANDARDS.
2. GUARDRAIL SHALL BE GALVANIZED STEEL 'W' BEAM HIGHWAY GUARD WITH GALVANIZED STEEL POSTS OR COR-TEN WEATHERING STEEL BEAM HIGHWAY GUARD WITH TREATED WOOD POSTS. THE TYPE OF GUARDRAIL TO BE USED WILL BE SPECIFIED BY THE DEDHAM DPW.
3. REGARDLESS OF POST TYPE USED, WHERE FULL 3'-3" OFFSET TO THE INTERSECTION OF TANGENTS (IT) IS NOT FEASIBLE DUE TO SITE CONSTRAINTS, THE POST LENGTH SHALL BE INCREASED TO 8'-0".

UNLESS OTHERWISE NOTED, CONSTRUCTION METHODS, MATERIAL REQUIREMENTS AND METHOD OF MEASUREMENT SHALL BE IN ACCORDANCE WITH THE LATEST EDITION OF THE MASSACHUSETTS DEPARTMENT OF TRANSPORTATION (MassDOT) STANDARD SPECIFICATIONS.

ALSO REFERENCE CURRENT MassDOT CONSTRUCTION STANDARD DETAILS.



**DEDHAM DPW  
DESIGN & CONSTRUCTION STANDARDS**

STEEL 'W' BEAM HIGHWAY GUARD (SINGLE FACED)  
VERTICAL GRAN. CURB OR ASPHALT CURB

SCALE: DATE OF ISSUE:  
NTS AUGUST 2015

REVISED:

DETAIL NUMBER:  
RS.28

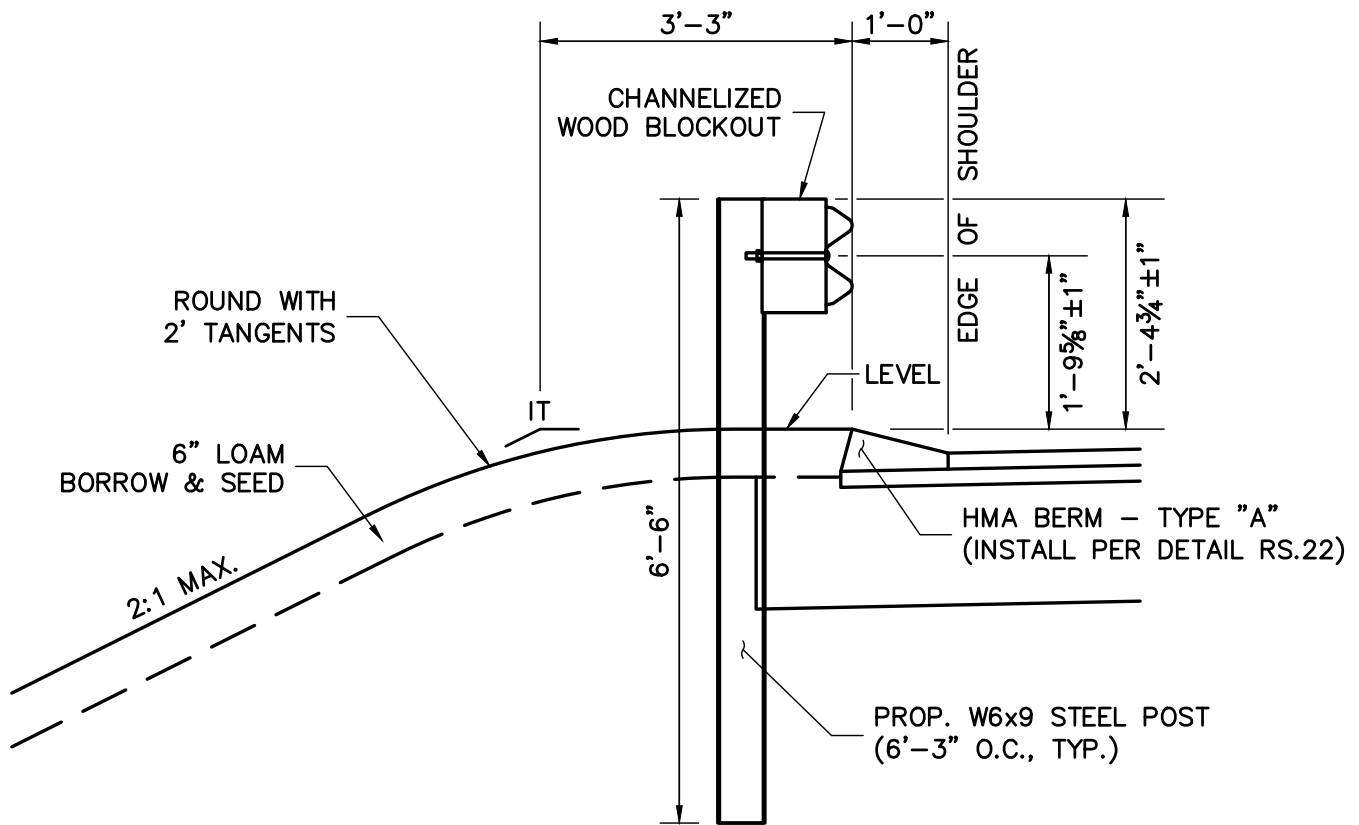

**STEEL POST SHOWN**

**NOTES:**

1. ALL GUARDRAIL SHALL BE INSTALLED IN ACCORDANCE WITH THE LATEST MassDOT CONSTRUCTION STANDARDS.
2. GUARDRAIL SHALL BE GALVANIZED STEEL 'W' BEAM HIGHWAY GUARD WITH GALVANIZED STEEL POSTS OR COR-TEN WEATHERING STEEL BEAM HIGHWAY GUARD WITH TREATED WOOD POSTS. THE TYPE OF GUARDRAIL TO BE USED WILL BE SPECIFIED BY THE DEDHAM DPW.
3. REGARDLESS OF POST TYPE USED, WHERE FULL 3'-3" OFFSET TO THE INTERSECTION OF TANGENTS (IT) IS NOT FEASIBLE DUE TO SITE CONSTRAINTS, THE POST LENGTH SHALL BE INCREASED TO 8'-0".

UNLESS OTHERWISE NOTED, CONSTRUCTION METHODS, MATERIAL REQUIREMENTS AND METHOD OF MEASUREMENT SHALL BE IN ACCORDANCE WITH THE LATEST EDITION OF THE MASSACHUSETTS DEPARTMENT OF TRANSPORTATION (MassDOT) STANDARD SPECIFICATIONS.

ALSO REFERENCE CURRENT MassDOT CONSTRUCTION STANDARD DETAILS.



**DEDHAM DPW  
DESIGN & CONSTRUCTION STANDARDS**

STEEL 'W' BEAM HIGHWAY GUARD (SINGLE FACED)  
HOT MIX ASPHALT BERM - TYPE "A"

SCALE: DATE OF ISSUE:  
NTS AUGUST 2015

REVISED:

DETAIL NUMBER:  
RS.29

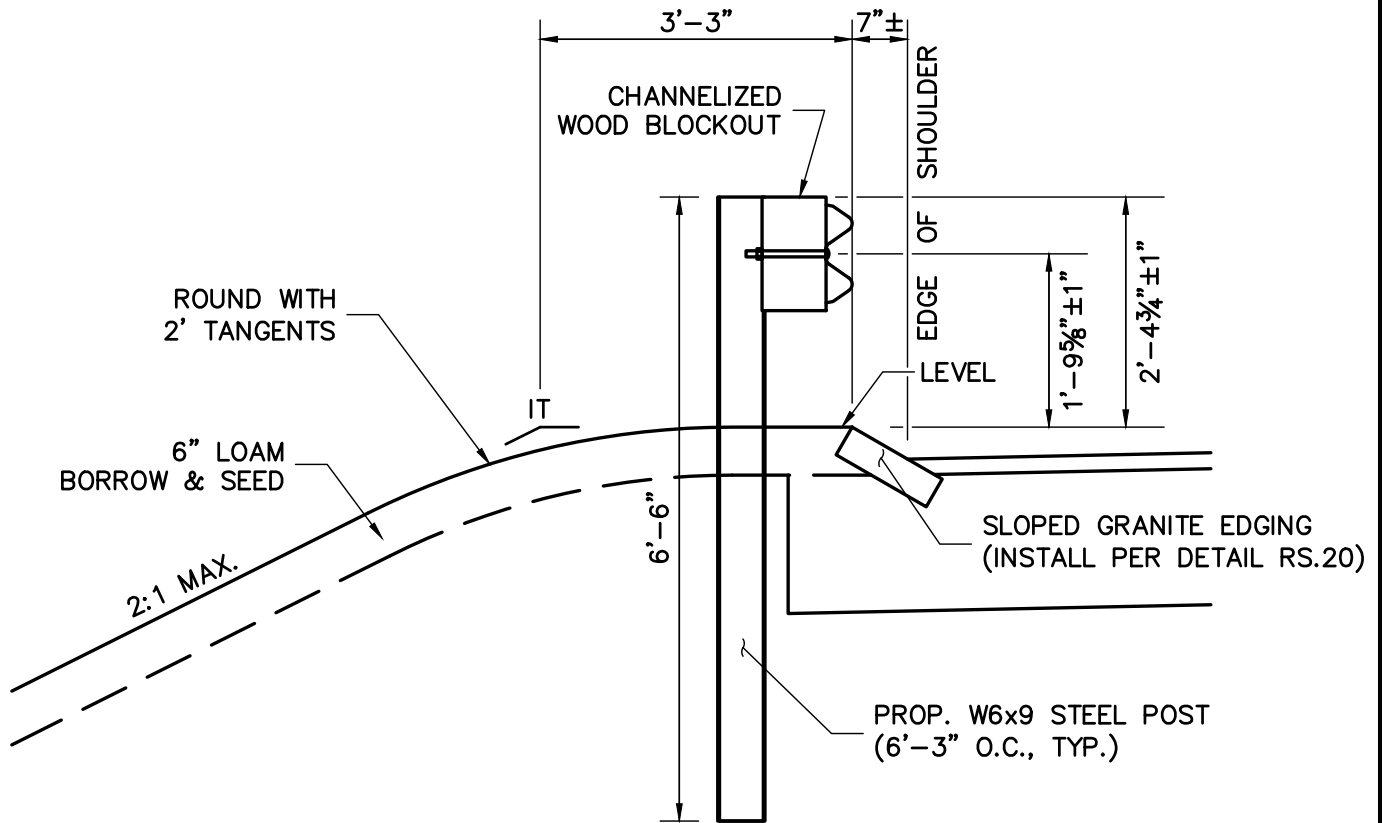

**STEEL POST SHOWN**

**NOTES:**

1. ALL GUARDRAIL SHALL BE INSTALLED IN ACCORDANCE WITH THE LATEST MassDOT CONSTRUCTION STANDARDS.
2. GUARDRAIL SHALL BE GALVANIZED STEEL 'W' BEAM HIGHWAY GUARD WITH GALVANIZED STEEL POSTS OR COR-TEN WEATHERING STEEL BEAM HIGHWAY GUARD WITH TREATED WOOD POSTS. THE TYPE OF GUARDRAIL TO BE USED WILL BE SPECIFIED BY THE DEDHAM DPW.
3. REGARDLESS OF POST TYPE USED, WHERE FULL 3'-3" OFFSET TO THE INTERSECTION OF TANGENTS (IT) IS NOT FEASIBLE DUE TO SITE CONSTRAINTS, THE POST LENGTH SHALL BE INCREASED TO 8'-0".

UNLESS OTHERWISE NOTED, CONSTRUCTION METHODS, MATERIAL REQUIREMENTS AND METHOD OF MEASUREMENT SHALL BE IN ACCORDANCE WITH THE LATEST EDITION OF THE MASSACHUSETTS DEPARTMENT OF TRANSPORTATION (MassDOT) STANDARD SPECIFICATIONS.

ALSO REFERENCE CURRENT MassDOT CONSTRUCTION STANDARD DETAILS.



**DEDHAM DPW  
DESIGN & CONSTRUCTION STANDARDS**

**STEEL 'W' BEAM HIGHWAY GUARD (SINGLE FACED)  
SLOPED GRANITE EDGING**

SCALE: DATE OF ISSUE:  
NTS AUGUST 2015

REVISED:

DETAIL NUMBER:  
RS.30

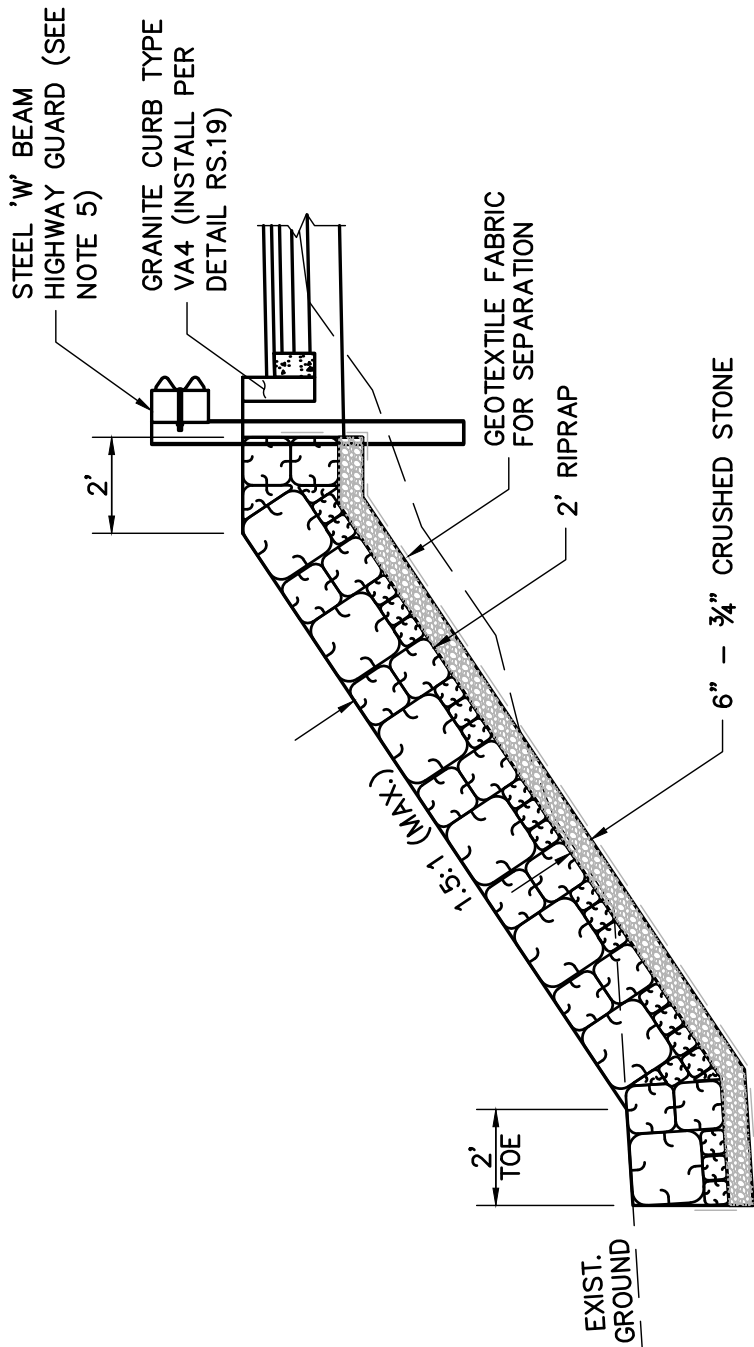

**NOTES:**

1. SLOPES STEEPER THAN 1.5:1 REQUIRE DESIGN BY GEOTECHNICAL ENGINEER REGISTERED IN THE COMMONWEALTH OF MASSACHUSETTS.
2. GEOTEXTILE FABRIC TO CONFORM TO AASHTO M 288.
3. CRUSHED STONE TO CONFORM TO MASSHIGHWAY M.2.01.4.
4. RIPRAP TO CONFORM TO MASSHIGHWAY M2.02.0.
5. GUARDRAIL IS REQUIRED FOR ALL RIPRAP SLOPES ADJACENT TO TO ROADWAY. DEPENDING ON PRESENCE AND TYPE OF CURBING, INSTALL GUARDRAIL PER DETAIL RS.28, RS.29 RS.30.

UNLESS OTHERWISE NOTED, CONSTRUCTION METHODS, MATERIAL REQUIREMENTS AND METHOD OF MEASUREMENT SHALL BE IN ACCORDANCE WITH THE LATEST EDITION OF THE MASSACHUSETTS DEPARTMENT OF TRANSPORTATION (MassDOT) STANDARD SPECIFICATIONS.

ALSO REFERENCE CURRENT MassDOT CONSTRUCTION STANDARD DETAILS.



**DEDHAM DPW  
DESIGN & CONSTRUCTION STANDARDS**

RIPRAP SLOPE

SCALE: NTS	DATE OF ISSUE: AUGUST 2015
REVISED:	
DETAIL NUMBER: RS.31	

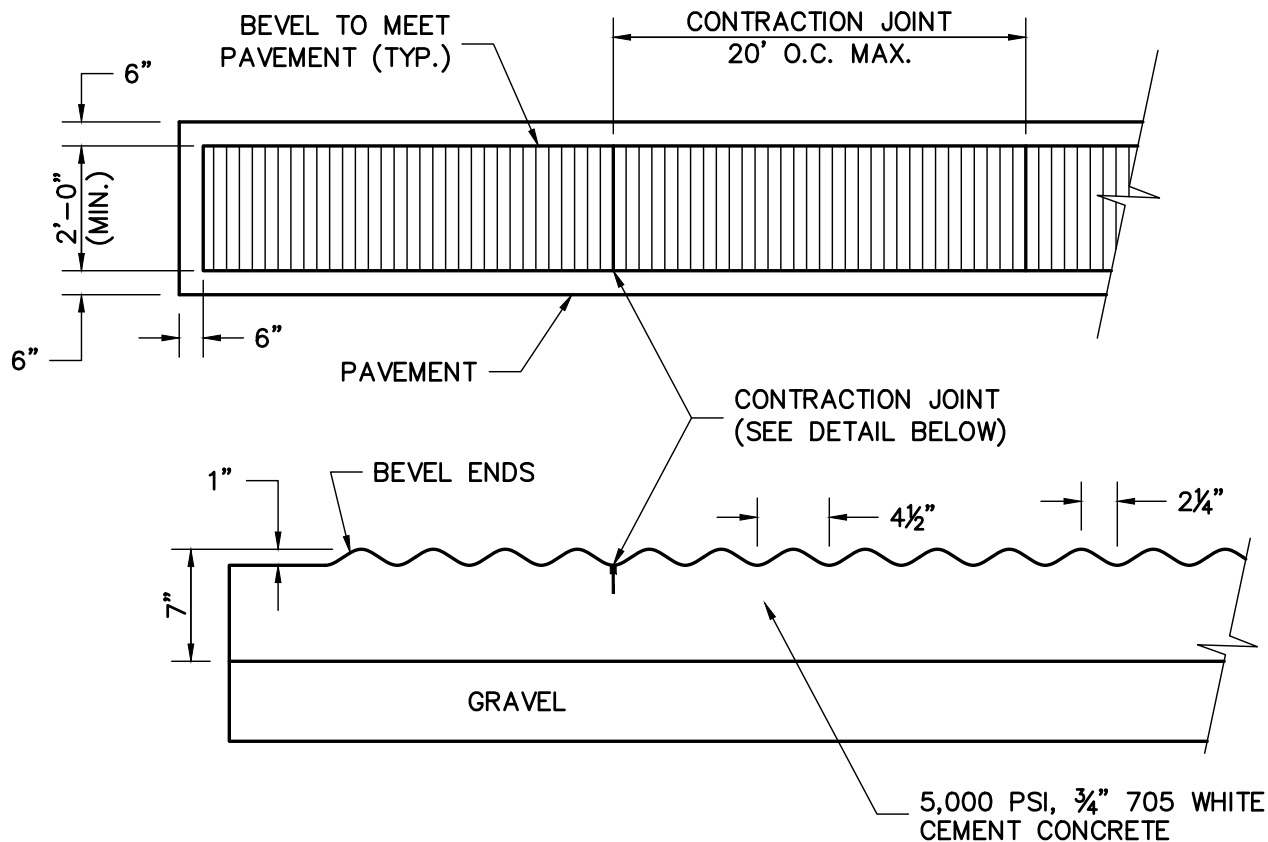

**NOTES:**

1. CONTRACTION JOINTS ARE TO BE PLACED AT A MAXIMUM OF 20 FEET APART.
2. JOINTS SHALL BE SAWN IN THE DEPRESSIONS AS SHOWN IN THE DETAIL AND IN ACCORDANCE WITH THE LATEST MassDOT SPECIFICATIONS.
3. END OF CORRUGATED RIDGES TO BE BEVELED WITH APPROPRIATE TOOL FOR UNIFORM SIZE AND SHAPE. HAND SCORING IS NOT ACCEPTABLE.
4. DEPTH OF GRAVEL TO BE SUCH THAT ITS BOTTOM LINE MEETS THE BOTTOM OF THE GRAVEL OF THE CONTIGUOUS PAVEMENT.

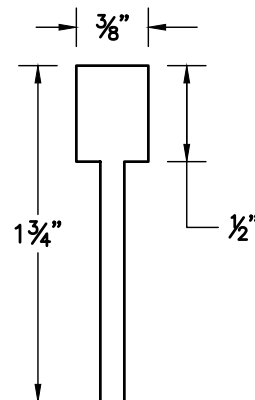

UNLESS OTHERWISE NOTED, CONSTRUCTION METHODS, MATERIAL REQUIREMENTS AND METHOD OF MEASUREMENT SHALL BE IN ACCORDANCE WITH THE LATEST EDITION OF THE MASSACHUSETTS DEPARTMENT OF TRANSPORTATION (MassDOT) STANDARD SPECIFICATIONS.

ALSO REFERENCE CURRENT MassDOT CONSTRUCTION STANDARD DETAILS.



**DEDHAM DPW  
DESIGN & CONSTRUCTION STANDARDS**

SCORED CONCRETE PAVEMENT

SCALE: NTS	DATE OF ISSUE: AUGUST 2015
---------------	-------------------------------

REVISED:

DETAIL NUMBER:  
RS.32



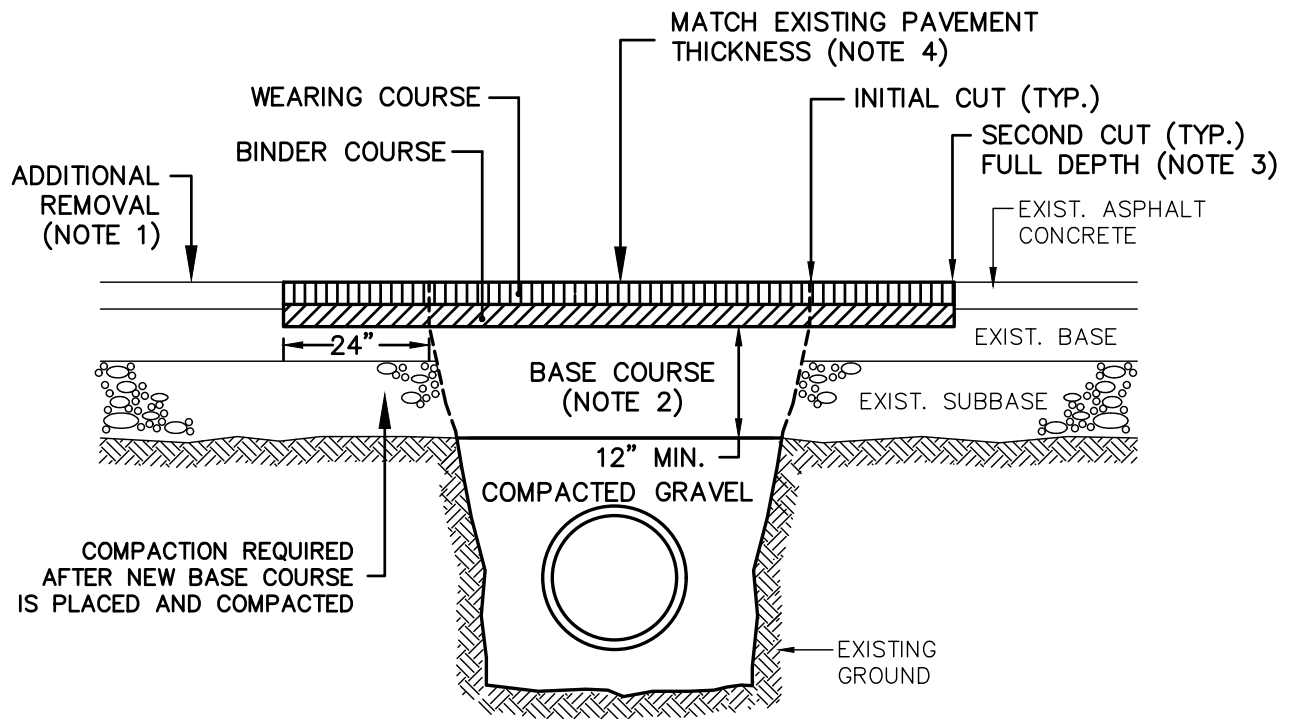

COMPACTION REQUIRED AFTER NEW BASE COURSE IS PLACED AND COMPACTED

- NOTES:
1. ADDITIONAL PAVEMENT REMOVAL – REMOVE ADDITIONAL PAVEMENT TO A PAINTED LANE STRIPE, A LIP OF GUTTER, A CURB, AN EXISTING PAVEMENT PATCH, OR AN EDGE OF THE PAVEMENT IF SUCH STREET FEATURE IS WITHIN 2’ OF THE SECOND SAW CUT.
  2. NEW BASE COURSE – PROVIDE BASE COURSE MATERIAL IN LIFTS NOT EXCEEDING 6” AFTER COMPACTION. COMPACT TO A MODIFIED PROCTOR DENSITY OF 95% OR GREATER.
  3. TACK COAT – PROVIDE FULL TACK COAT COVERAGE ON ALL VERTICAL SURFACES.
  4. NEW ASPHALT PAVEMENT – THICKNESS SHALL EITHER BE EQUIVALENT TO EXISTING CONDITION OR MEET DETAIL RS.01, WHICHEVER IS GREATER. COMPACT THE NEW PAVEMENT TO 96% OF LABORATORY DENSITY OR 94% OF MAXIMUM THEORETICAL DENSITY. INSTALL ASPHALT IN 2” LIFTS, MAXIMUM.

UNLESS OTHERWISE NOTED, CONSTRUCTION METHODS, MATERIAL REQUIREMENTS AND METHOD OF MEASUREMENT SHALL BE IN ACCORDANCE WITH THE LATEST EDITION OF THE MASSACHUSETTS DEPARTMENT OF TRANSPORTATION (MassDOT) STANDARD SPECIFICATIONS.

ALSO REFERENCE CURRENT MassDOT CONSTRUCTION STANDARD DETAILS.



**DEDHAM DPW  
DESIGN & CONSTRUCTION STANDARDS**

SHALLOW EXCAVATION IN ASPHALT PAVEMENT  
42” DEPTH OR LESS

SCALE: NTS	DATE OF ISSUE: AUGUST 2015
REVISED:	
DETAIL NUMBER: RS.33	

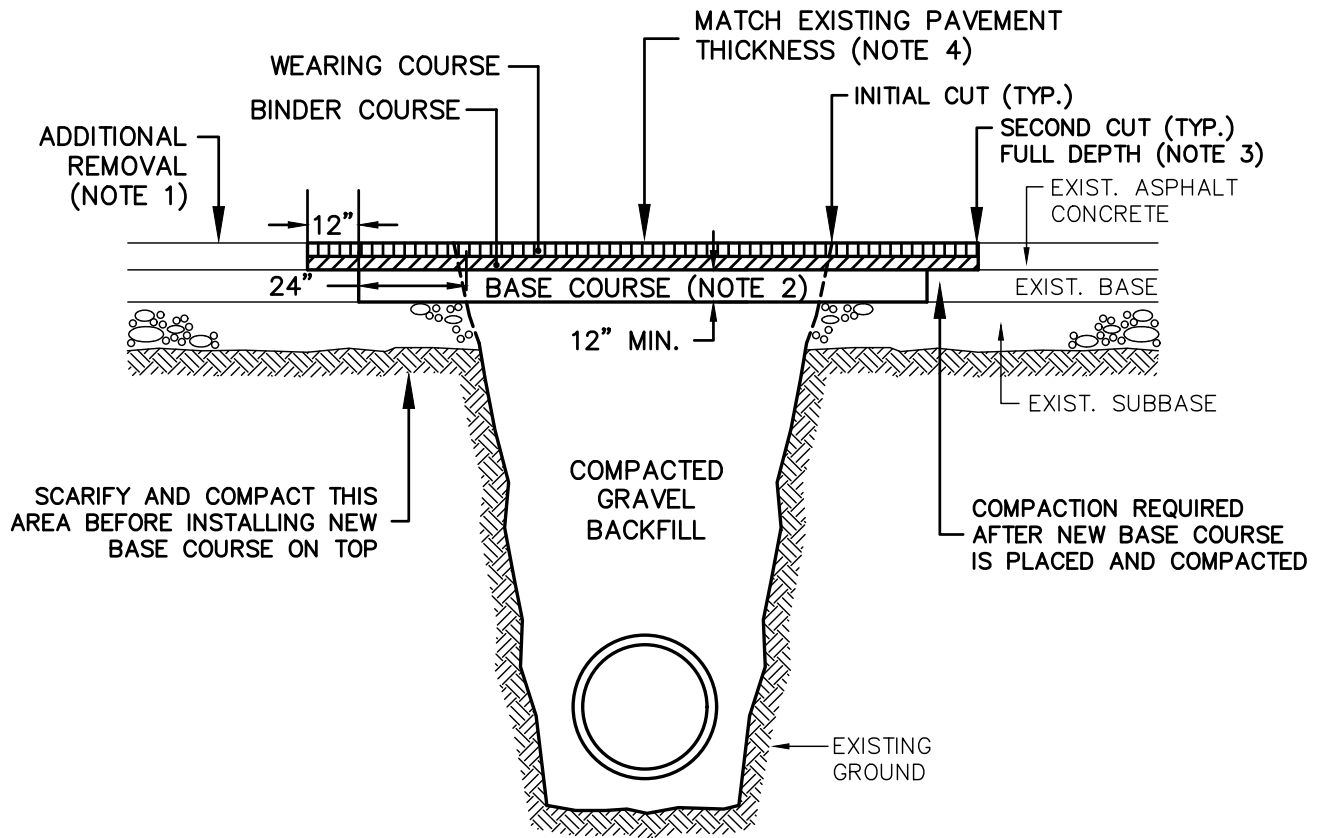

**NOTES:**

1. ADDITIONAL PAVEMENT REMOVAL – REMOVE ADDITIONAL PAVEMENT TO A PAINTED LANE STRIPE, A LIP OF GUTTER, A CURB, AN EXISTING PAVEMENT PATCH, OR AN EDGE OF THE PAVEMENT IF SUCH STREET FEATURE IS WITHIN 2’ OF THE SECOND SAW CUT.
2. NEW BASE COURSE – PROVIDE BASE COURSE MATERIAL IN LIFTS NOT EXCEEDING 6” AFTER COMPACTION. COMPACT TO A MODIFIED PROCTOR DENSITY OF 95% OR GREATER.
3. TACK COAT – PROVIDE FULL TACK COAT COVERAGE ON ALL VERTICAL SURFACES.
4. NEW ASPHALT PAVEMENT – THICKNESS SHALL EITHER BE EQUIVALENT TO EXISTING CONDITION OR MEET DETAIL RS.01, WHICHEVER IS GREATER. COMPACT THE NEW PAVEMENT TO 96% OF LABORATORY DENSITY OR 94% OF MAXIMUM THEORETICAL DENSITY. INSTALL ASPHALT IN 2” LIFTS, MAXIMUM.

UNLESS OTHERWISE NOTED, CONSTRUCTION METHODS, MATERIAL REQUIREMENTS AND METHOD OF MEASUREMENT SHALL BE IN ACCORDANCE WITH THE LATEST EDITION OF THE MASSACHUSETTS DEPARTMENT OF TRANSPORTATION (MassDOT) STANDARD SPECIFICATIONS.

ALSO REFERENCE CURRENT MassDOT CONSTRUCTION STANDARD DETAILS.



**DEDHAM DPW  
DESIGN & CONSTRUCTION STANDARDS**

DEEP EXCAVATION IN ASPHALT PAVEMENT  
GREATER THAN 42” IN DEPTH

SCALE: NTS	DATE OF ISSUE: AUGUST 2015
REVISED:	
DETAIL NUMBER: RS.34	

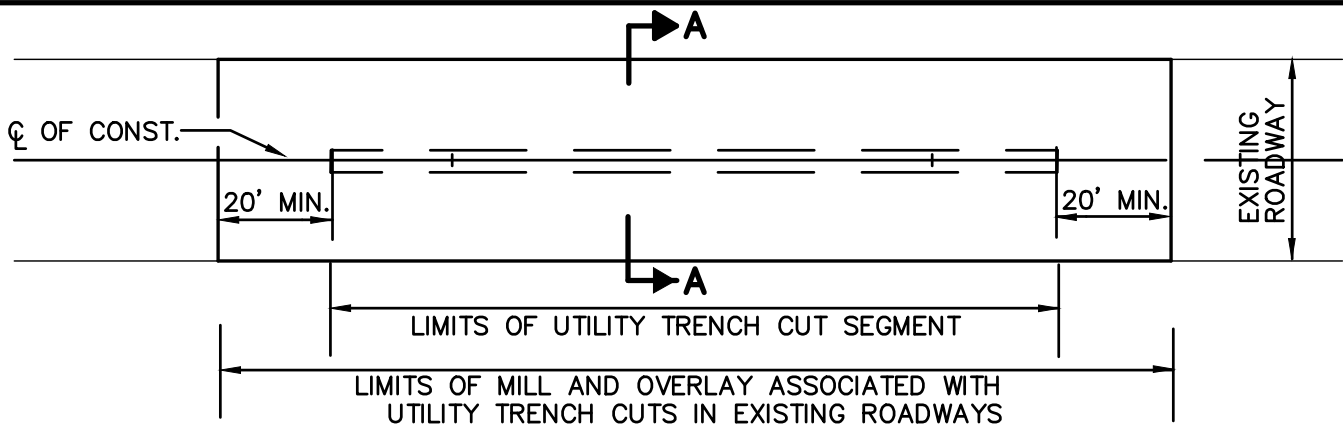

**PLAN VIEW**

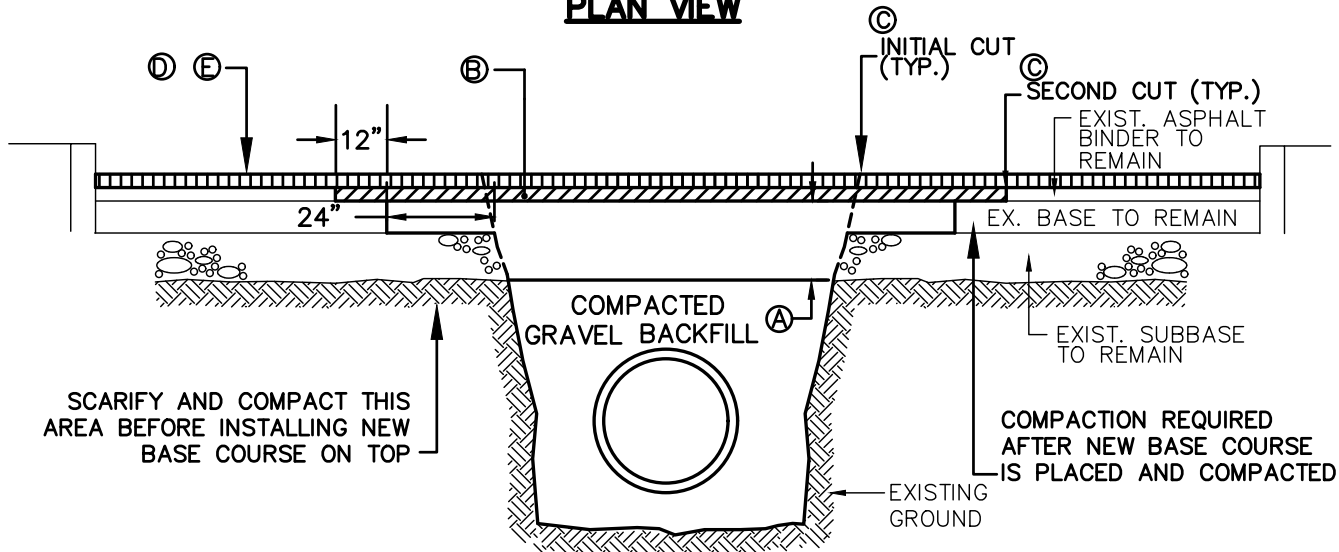

**SECTION A-A**

- Ⓐ ADD 12" COMPACTED GRAVEL BASE COURSE TO LIMITS SHOWN.
- Ⓑ INSTALL NOT LESS THAN A 2" COMPACTED BITUMINOUS CONCRETE BINDER TO LIMITS SHOWN.
- Ⓒ SEAL ALL CUT PAVEMENT JOINTS AND EDGES WITH HOT-POURED LIQUID ASPHALT.
- Ⓓ FINAL OVERLAY OVER THE GRINDED FULL WIDTH ROADWAY TO LIMITS SHOWN IN PLAN ABOVE. TYPICAL 2" COMPACTED TYPE 1-1 BITUMINOUS CONCRETE ROLLED CURB TO CURB WITHOUT SURFACE BUMPS OR DEPRESSIONS AND FLUSH WITH FACE OF CURBS OR EXISTING EDGES.
- Ⓔ RE-ESTABLISH ALL DISTURBED CENTERLINE AND GUTTERLINE THERMOPLASTIC MARKINGS.

UNLESS OTHERWISE NOTED, CONSTRUCTION METHODS, MATERIAL REQUIREMENTS AND METHOD OF MEASUREMENT SHALL BE IN ACCORDANCE WITH THE LATEST EDITION OF THE MASSACHUSETTS DEPARTMENT OF TRANSPORTATION (MassDOT) STANDARD SPECIFICATIONS.

ALSO REFERENCE CURRENT MassDOT CONSTRUCTION STANDARD DETAILS.



**DEDHAM DPW  
DESIGN & CONSTRUCTION STANDARDS**

**PAVEMENT RESTORATION FOR UTILITY TRENCHING  
IN CRACKED PAVEMENT AREAS**

SCALE: NTS      DATE OF ISSUE:  
AUGUST 2015

REVISED:

DETAIL NUMBER:  
RS.35

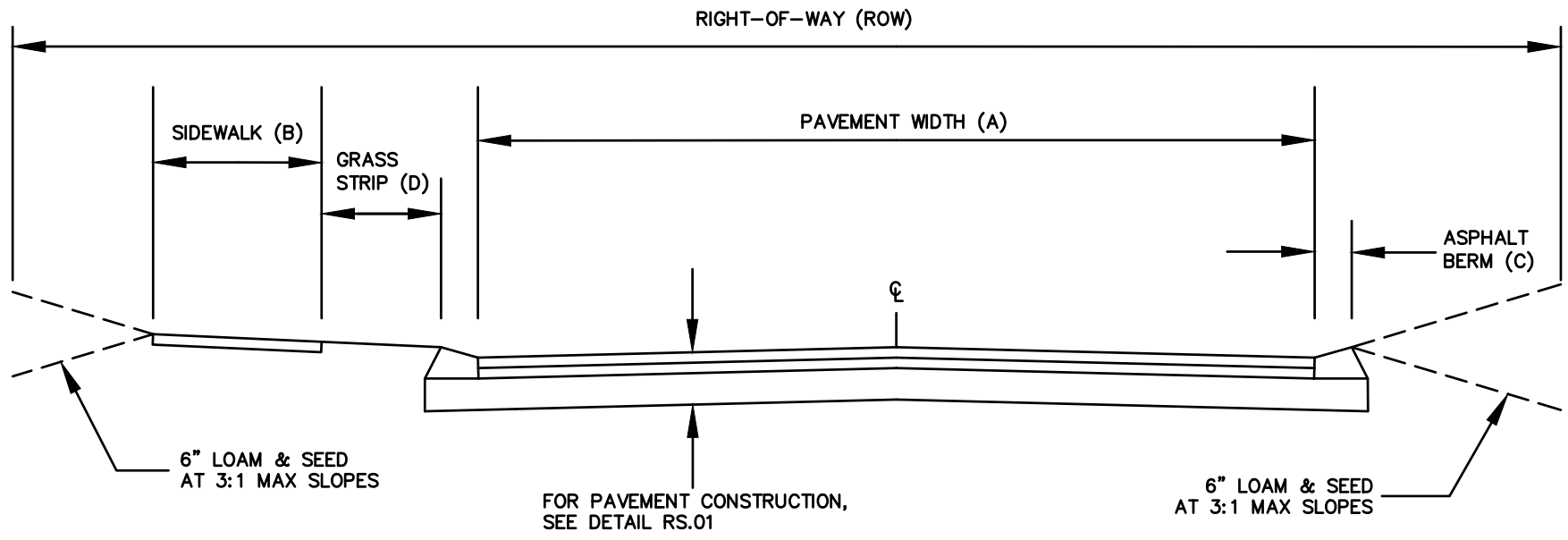

**TYPICAL ROADWAY CROSS-SECTION**

ROADWAY CROSS-SECTION	MINIMUM ROADWAY SECTION WIDTHS (FT)				
	ROW	(A)	(B)	(C)	(D)
CROSS-SECTION #1	35	22	5*	1	-
CROSS-SECTION #2	40	28	5*	1	-
CROSS-SECTION #3	40	24	5*	1	3
CROSS-SECTION #4	30	24	-	1	-

\* SIDEWALKS WILL BE REQUIRED; IF THE PRIVATE WAY LEADS TO A PUBLIC FACILITY, IF THE PRIVATE WAY INTERSECTS A PUBLIC WAY THAT HAS AN EXISTING SIDEWALK OR WHERE A SIDEWALK CURRENTLY EXISTS ON THE PRIVATE WAY.

NOTES:

1. ALL PRIVATE WAYS PETITIONING TO BECOME A PUBLIC WAY WILL BE CONSTRUCTED HAVING A CROSS-SECTIONAL DETAIL AS DESCRIBED IN THE TYPICAL ROADWAY CROSS-SECTION TABLE. THE CROSS-SECTION UTILIZED WILL BE DETERMINED BY THE ENGINEERING DEPARTMENT.
2. PARKING WILL ONLY BE ALLOWED ALONG ONE SIDE OF THE ROADWAY FOR CROSS-SECTIONS #1, #3 AND #4.
3. PARKING WILL BE ALLOWED ON BOTH SIDES OF THE ROADWAY FOR CROSS-SECTION #2. THE PARKING WILL BE STRUCTURED ALONG BOTH SIDES OF THE ROADWAY TO ALLOW EMERGENCY RESPONSE VEHICLES THE NECESSARY OPEN LANE WIDTH TO SAFELY AND EFFICIENTLY NEGOTIATE THE ROADWAY.

**DEDHAM DPW  
DESIGN & CONSTRUCTION STANDARDS**

TYPICAL ROADWAY CROSS-SECTION FOR THE  
ACCEPTANCE OF A PRIVATE WAY AS A PUBLIC WAY

SCALE:  
NTS

DATE OF ISSUE:  
AUGUST 2015

DETAIL NUMBER:  
RS.36



# STORM DRAIN & STORMWATER MANAGEMENT

**DESCRIPTION**

**DETAIL NUMBER**

**CATCH BASIN**

FRAME & GRATE	SDSW.01
PRECAST CONCRETE CATCH BASIN	SDSW.02
OIL & DEBRIS TRAP – SNOUT 18R INSTALLATION DETAILS	SDSW.02A
ALTERNATE TYPE CATCH BASIN (SECTION)	SDSW.03
ALTERNATE TYPE CATCH BASIN (PLAN)	SDSW.03A
ALTERNATE TYPE CATCH BASIN (NOTES)	SDSW.03B

GRANITE CURB INLET	SDSW.04
--------------------	---------

CONCRETE BLOCK GUTTER INLET	SDSW.05
-----------------------------	---------

LEACHING BASIN	SDSW.06
----------------	---------

**ENVIRONMENTAL PLACARD**

DRAINS TO CHARLES RIVER	SDSW.07
DRAINS TO NEPONSET RIVER	SDSW.08

PRECAST DRAIN MANHOLE	SDSW.09
MANHOLE FRAME & COVER MARKED "DRAIN"	SDSW.10

**DRAINAGE END & SLOPE TREATMENTS**

CONCRETE OR FIELD STONE MASONRY ENDS	SDSW.11
REINFORCED CONCRETE FLARED END SECTION	SDSW.12
RIPRAP VELOCITY DISSIPATOR	SDSW.13
STONE OUTLET PROTECTION	SDSW.14
OUTLET PROTECTION TABLE FOR LOW TAILWATER	SDSW.14A
OUTLET PROTECTION TABLE FOR HIGH TAILWATER	SDSW.14B
RIPRAP DITCH	SDSW.15

**TRENCHES**

DRAINAGE TRENCH	SDSW.16
ANTI-SEEP COLLAR	SDSW.17



**DEDHAM DPW  
DESIGN & CONSTRUCTION STANDARDS**

DETAIL INDEX  
STORM DRAIN & STORMWATER MANAGEMENT

SCALE: NTS	DATE OF ISSUE: AUGUST 2015
---------------	-------------------------------

REVISED:

DETAIL NUMBER: SDSW-INDEX.01
---------------------------------

# STORM DRAIN & STORMWATER MANAGEMENT CONTINUED

**DESCRIPTION**

**DETAIL NUMBER**

**EROSION CONTROL PROTECTION**

SILT FENCE  
BALES OF HAY & SILT FENCE  
DRAIN INLET PROTECTION

SDSW.18  
SDSW.19  
SDSW.20



**DEDHAM DPW  
DESIGN & CONSTRUCTION STANDARDS**

DETAIL INDEX  
STORM DRAIN & STORMWATER MANAGEMENT

SCALE: NTS	DATE OF ISSUE: AUGUST 2015
---------------	-------------------------------

REVISED:

DETAIL NUMBER: SDSW-INDEX.02
---------------------------------

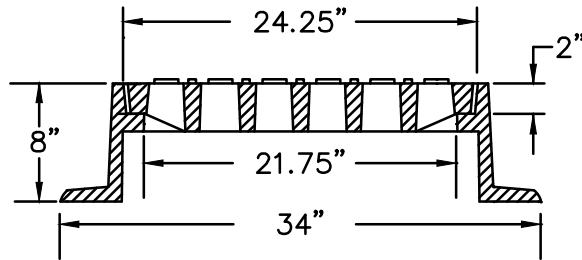
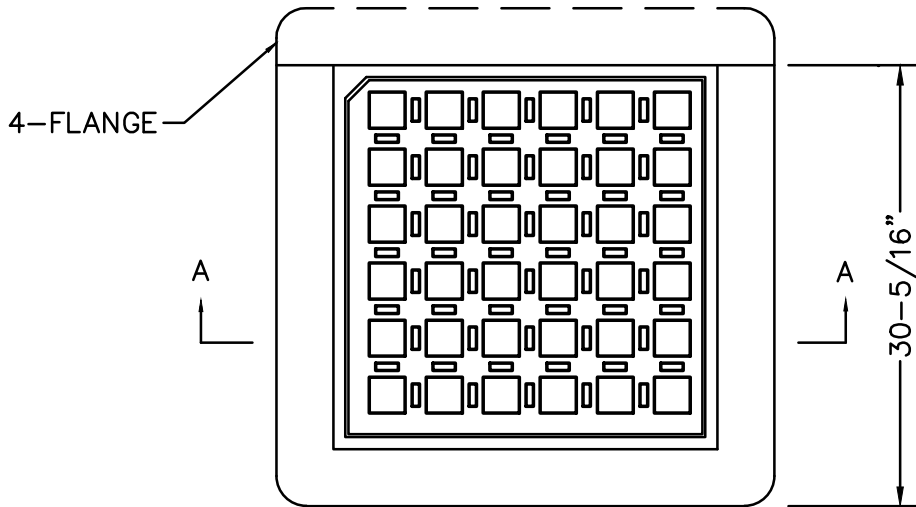

**SECTION A-A**

NOTE:

FRAME AND GRATE SHALL BE EAST JORDAN IRON WORKS CATALOG NOS. 5520M5 & 5524Z FOR THE 4-FLANGE AND CATALOG NOS. 5520M5 & 5523Z FOR THE 3-FLANGE, OR APPROVED EQUAL.

UNLESS OTHERWISE NOTED, CONSTRUCTION METHODS, MATERIAL REQUIREMENTS AND METHOD OF MEASUREMENT SHALL BE IN ACCORDANCE WITH THE LATEST EDITION OF THE MASSACHUSETTS DEPARTMENT OF TRANSPORTATION (MassDOT) STANDARD SPECIFICATIONS.

ALSO REFERENCE CURRENT MassDOT CONSTRUCTION STANDARD DETAILS.



**DEDHAM DPW  
DESIGN & CONSTRUCTION STANDARDS**

CATCH BASIN FRAME & GRATE

SCALE: NTS      DATE OF ISSUE: AUGUST 2015

REVISED:

DETAIL NUMBER: SDSW.01

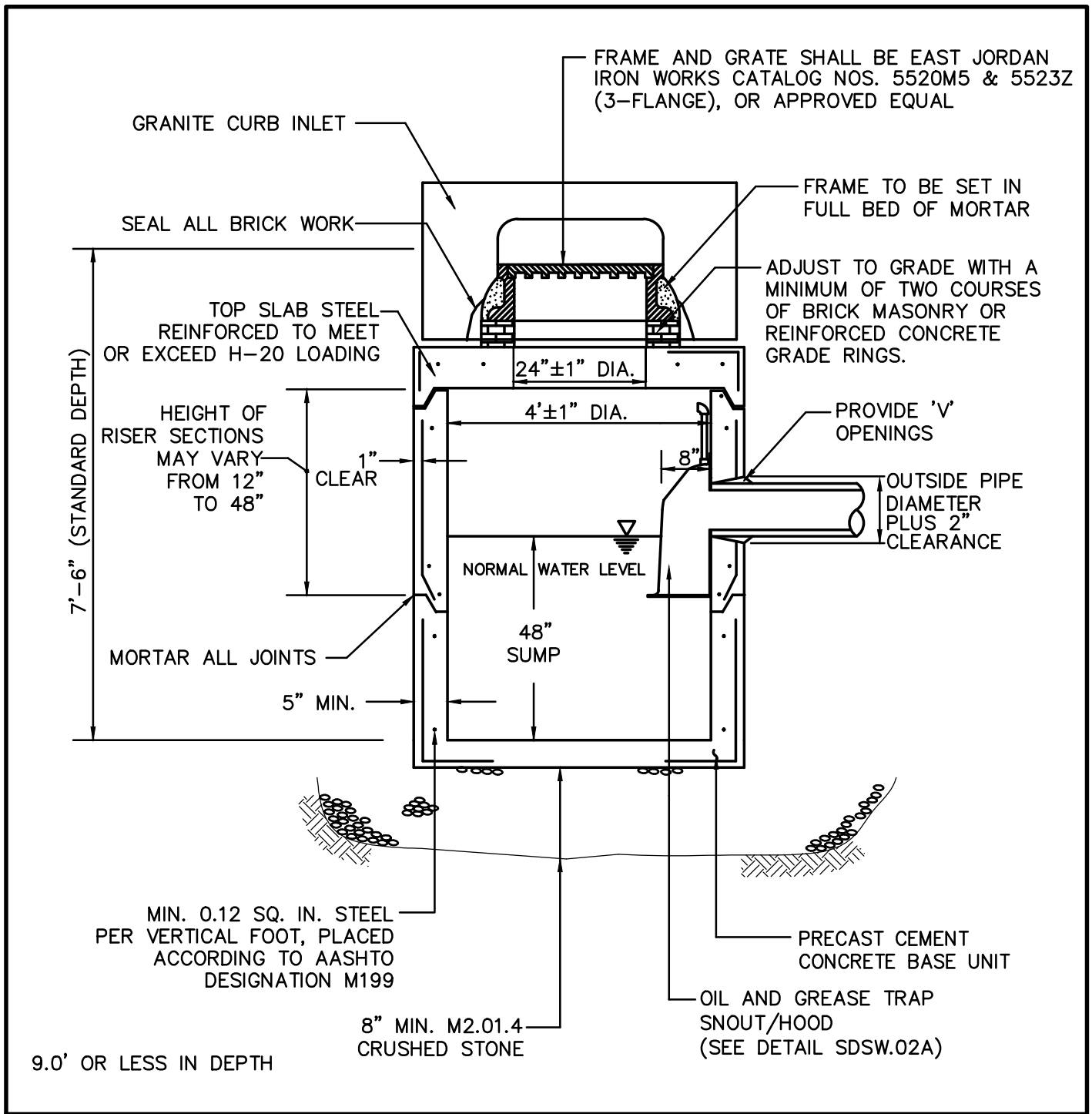

UNLESS OTHERWISE NOTED, CONSTRUCTION METHODS, MATERIAL REQUIREMENTS AND METHOD OF MEASUREMENT SHALL BE IN ACCORDANCE WITH THE LATEST EDITION OF THE MASSACHUSETTS DEPARTMENT OF TRANSPORTATION (MassDOT) STANDARD SPECIFICATIONS.

ALSO REFERENCE CURRENT MassDOT CONSTRUCTION STANDARD DETAILS.



**DEDHAM DPW  
DESIGN & CONSTRUCTION STANDARDS**

**PRECAST CONCRETE CATCH BASIN**

SCALE: DATE OF ISSUE:  
NTS AUGUST 2015

REVISED:

DETAIL NUMBER:  
SDSW.02



# INSTALLATION DETAIL

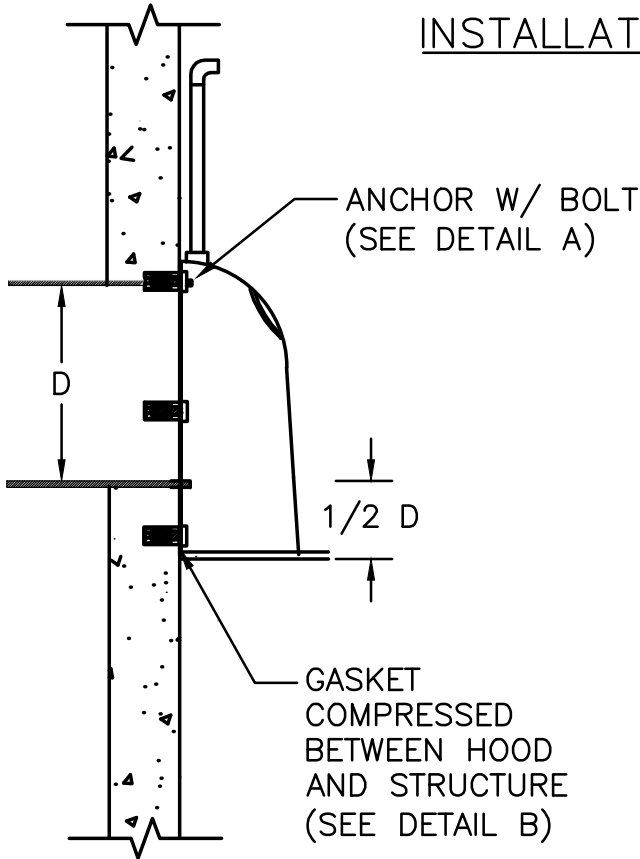

DETAIL B

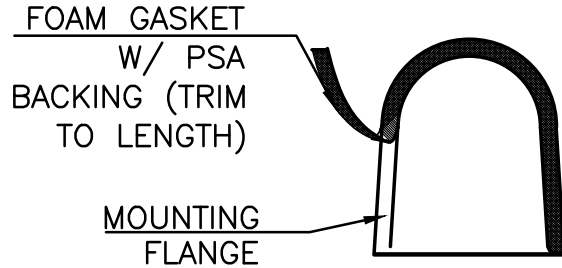

INSTALLATION NOTE:

POSITION HOOD SUCH THAT BOTTOM FLANGE IS A DISTANCE OF 1/2 OUTLET PIPE DIAMETER (MIN.) BELOW THE PIPE INVERT. MINIMUM DISTANCE FOR PIPES < 12" I.D. IS 6".

NOTE:  
 SNOUT/HOOD SHALL BE BMP, INC. 18R (SHOWN), GROUND WATER RESCUE, INC. ELIMINATOR, OR APPROVED EQUAL

DETAIL A

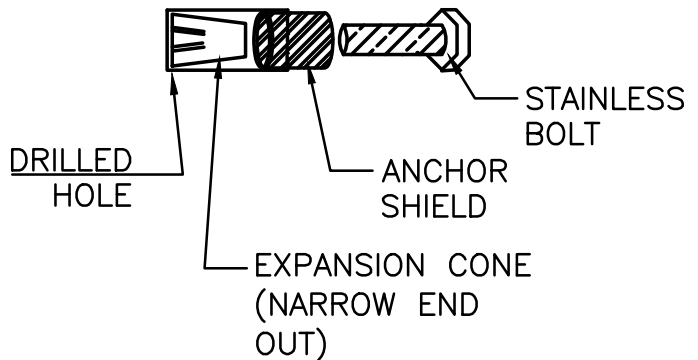

UNLESS OTHERWISE NOTED, CONSTRUCTION METHODS, MATERIAL REQUIREMENTS AND METHOD OF MEASUREMENT SHALL BE IN ACCORDANCE WITH THE LATEST EDITION OF THE MASSACHUSETTS DEPARTMENT OF TRANSPORTATION (MassDOT) STANDARD SPECIFICATIONS.

ALSO REFERENCE CURRENT MassDOT CONSTRUCTION STANDARD DETAILS.



## DEDHAM DPW DESIGN & CONSTRUCTION STANDARDS

OIL AND DEBRIS TRAP  
 SNOUT 18R INSTALLATION DETAILS

SCALE: NTS	DATE OF ISSUE: AUGUST 2015
REVISED:	
DETAIL NUMBER: SDSW.02A	

**NOTE:**

1. FRAMES AND GRATES/COVERS SHALL BE ADJUSTED TO GRADE WITH A MINIMUM OF TWO COURSES OF BRICK MASONRY OR REINFORCED CONCRETE GRADE RINGS (NOT SHOWN).
2. ALL EXTERIOR SURFACES OF MANHOLE GRADE ADJUSTMENT COURSES SHALL BE COVERED WITH 1/4" TO 3/8" MASONRY CEMENT PLASTER.

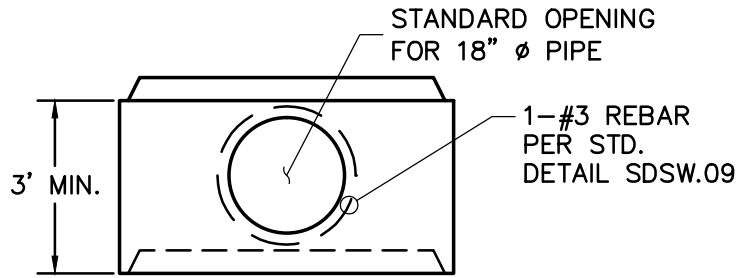

**INLET RISER**

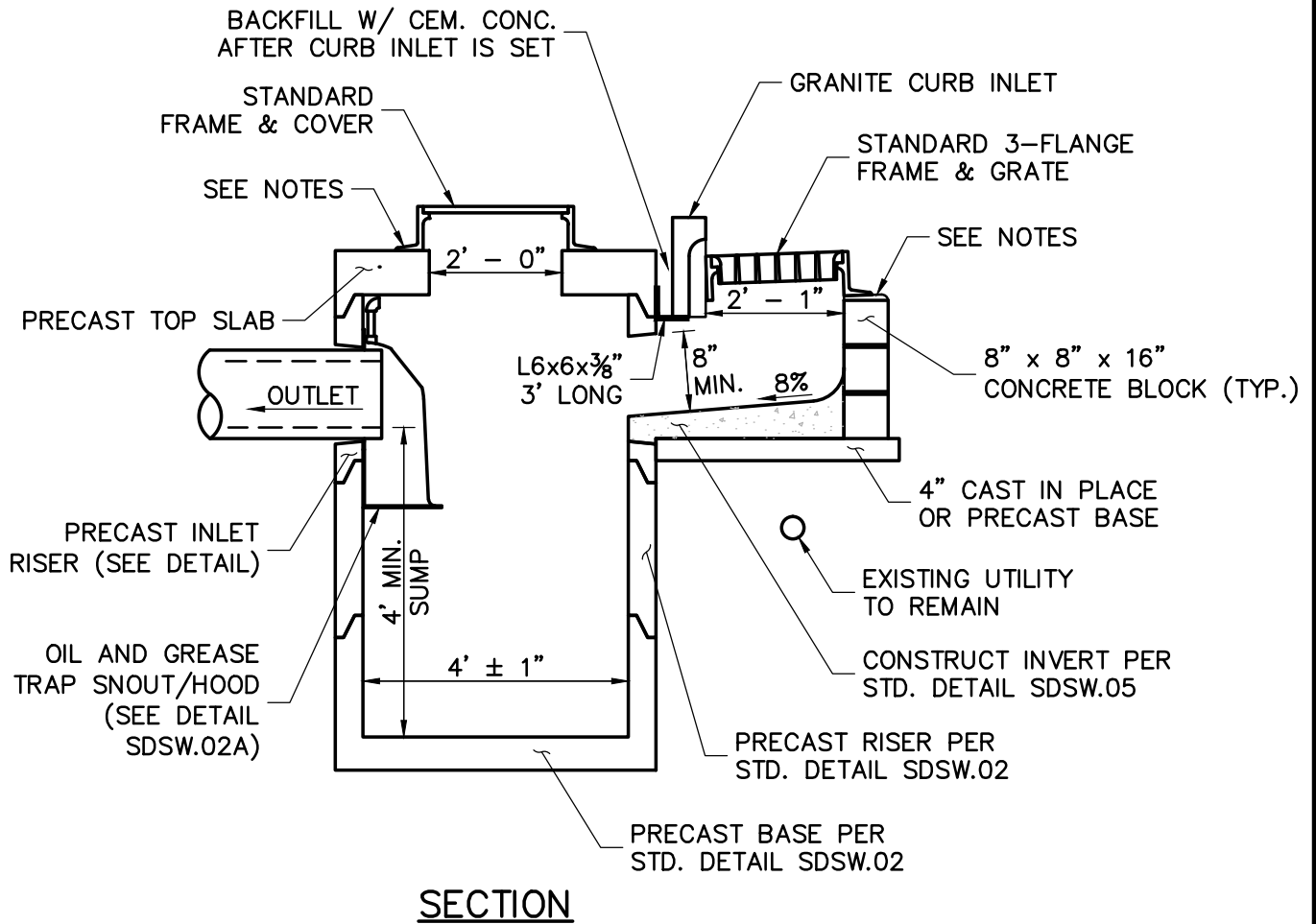

**SECTION**

UNLESS OTHERWISE NOTED, CONSTRUCTION METHODS, MATERIAL REQUIREMENTS AND METHOD OF MEASUREMENT SHALL BE IN ACCORDANCE WITH THE LATEST EDITION OF THE MASSACHUSETTS DEPARTMENT OF TRANSPORTATION (MassDOT) STANDARD SPECIFICATIONS.

ALSO REFERENCE CURRENT MassDOT CONSTRUCTION STANDARD DETAILS.



**DEDHAM DPW  
DESIGN & CONSTRUCTION STANDARDS**

ALTERNATE TYPE CATCH BASIN  
SECTION

SCALE: DATE OF ISSUE:  
NTS AUGUST 2015

REVISED:

DETAIL NUMBER:  
SDSW.03

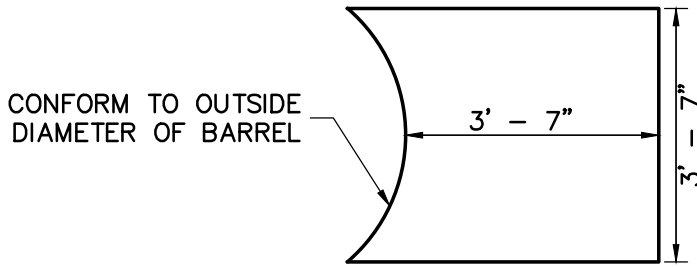

**BASE DIMENSIONS**

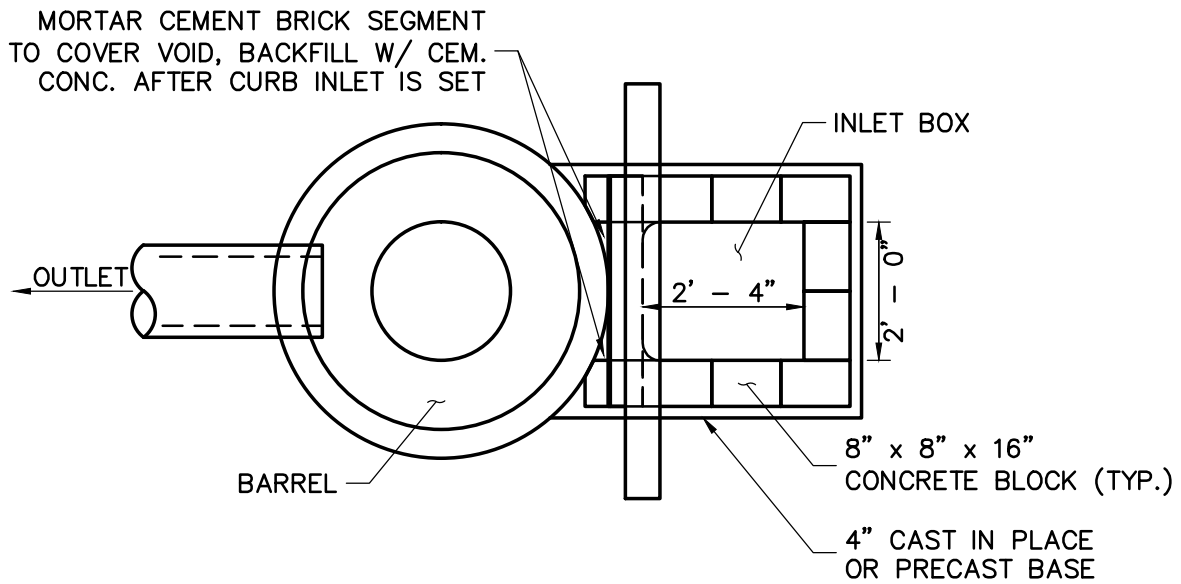

**PLAN**

UNLESS OTHERWISE NOTED, CONSTRUCTION METHODS, MATERIAL REQUIREMENTS AND METHOD OF MEASUREMENT SHALL BE IN ACCORDANCE WITH THE LATEST EDITION OF THE MASSACHUSETTS DEPARTMENT OF TRANSPORTATION (MassDOT) STANDARD SPECIFICATIONS.

ALSO REFERENCE CURRENT MassDOT CONSTRUCTION STANDARD DETAILS.



**DEDHAM DPW  
DESIGN & CONSTRUCTION STANDARDS**

ALTERNATE TYPE CATCH BASIN  
PLAN

SCALE: NTS	DATE OF ISSUE: AUGUST 2015
---------------	-------------------------------

REVISED:

DETAIL NUMBER: SDSW.03A
----------------------------

ALTERNATE TYPE CATCH BASIN NOTES:

1. ALTERNATE TYPE CATCH BASINS ARE TO BE USED AT LOCATIONS WHERE A STANDARD CATCH BASIN WOULD REQUIRE THE RELOCATION OF AN EXISTING UTILITY.
2. REINFORCEMENT IN BARREL SECTIONS SHALL BE AS SHOWN IN STANDARD DETAIL SDSW.02.
3. THE 6x6x $\frac{3}{8}$  INCH ANGLE SHALL BE GALVANIZED IN ACCORDANCE WITH AASHTO M111.
4. BRICKS MAY BE USED TO ADJUST THE GRADE OF THE FRAMES.
5. THE CURB INLET SHALL BE SET IN A FULL BED OF MORTAR ON THE STEEL ANGLE. THE MINIMUM WIDTH OF BEARING OF THE CURB INLET ON THE STEEL ANGLE SHALL BE 3 INCHES.
6. THE OUTLET IS NOT NECESSARILY LOCATED WITHIN THE INLET RISER AND IS NOT NECESSARILY LOCATED OPPOSITE FROM THE INLET. THE CONTRACTOR IS SOLELY RESPONSIBLE FOR DETERMINING THE RELATIVE LOCATIONS OF THE INLET AND OUTLET PRIOR TO ORDERING.
7. THE OUTLET PIPE SHALL NOT PROJECT MORE THAN 4 INCHES FROM THE FACE OF THE INTERIOR WALL ALONG THE CENTERLINE OF THE PIPE.
8. CONCRETE BLOCKS IN THE INLET BOX SHALL BE SET IN A FULL BED OF MORTAR. ALL HORIZONTAL AND VERTICAL JOINTS SHALL BE FLUSHED FULL OF MORTAR.
9. A MINIMUM CLEARANCE BETWEEN THE TOP OF THE 18-INCH OPENING IN THE INLET RISER AND THE INVERT OF THE INLET BOX IS 8 INCHES. THE NUMBER OF ROWS OF CONCRETE BLOCKS IN THE INLET BOX MAY BE MODIFIED DEPENDING ON THE ELEVATION OF THE UTILITY TO BE MAINTAINED.

UNLESS OTHERWISE NOTED, CONSTRUCTION METHODS, MATERIAL REQUIREMENTS AND METHOD OF MEASUREMENT SHALL BE IN ACCORDANCE WITH THE LATEST EDITION OF THE MASSACHUSETTS DEPARTMENT OF TRANSPORTATION (MassDOT) STANDARD SPECIFICATIONS.

ALSO REFERENCE CURRENT MassDOT CONSTRUCTION STANDARD DETAILS.



**DEDHAM DPW  
DESIGN & CONSTRUCTION STANDARDS**

ALTERNATE TYPE CATCH BASIN  
NOTES

SCALE: DATE OF ISSUE:  
NTS AUGUST 2015

REVISED:

DETAIL NUMBER:  
SDSW.03B

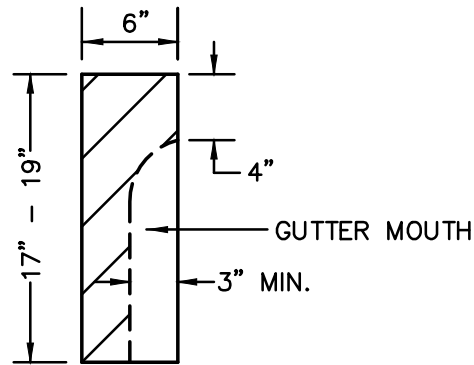
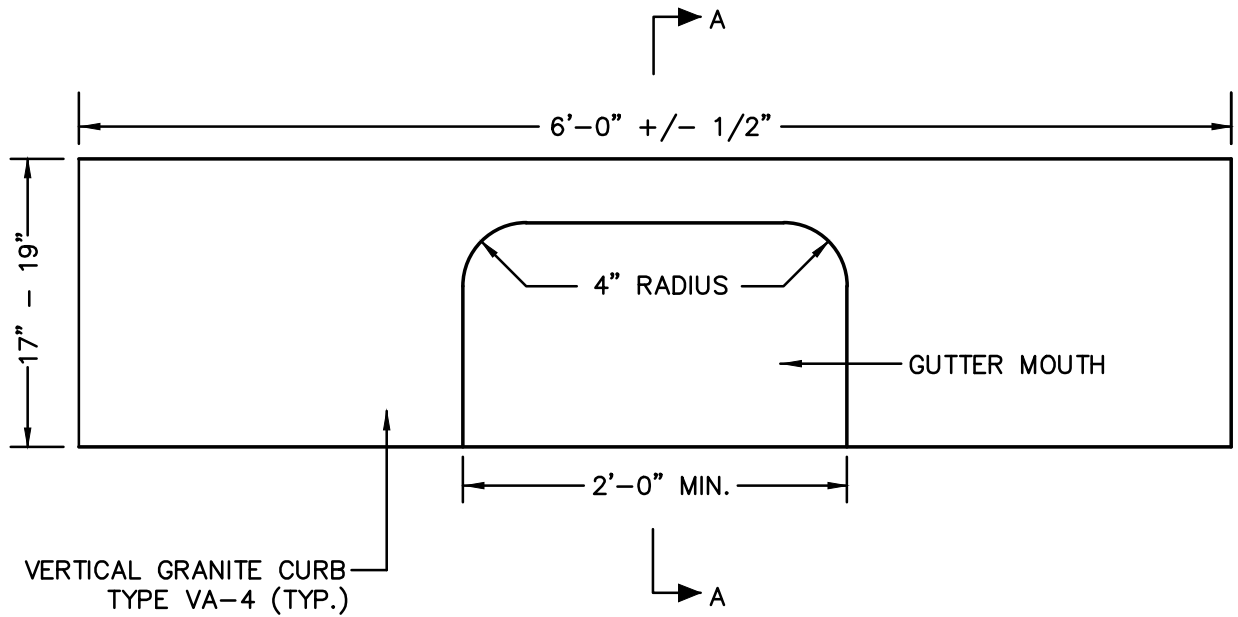

**SECTION A-A**

UNLESS OTHERWISE NOTED, CONSTRUCTION METHODS, MATERIAL REQUIREMENTS AND METHOD OF MEASUREMENT SHALL BE IN ACCORDANCE WITH THE LATEST EDITION OF THE MASSACHUSETTS DEPARTMENT OF TRANSPORTATION (MassDOT) STANDARD SPECIFICATIONS.

ALSO REFERENCE CURRENT MassDOT CONSTRUCTION STANDARD DETAILS.



**DEDHAM DPW  
DESIGN & CONSTRUCTION STANDARDS**

GRANITE CURB INLET

SCALE: DATE OF ISSUE:  
NTS AUGUST 2015

REVISED:

DETAIL NUMBER:  
SDSW.04

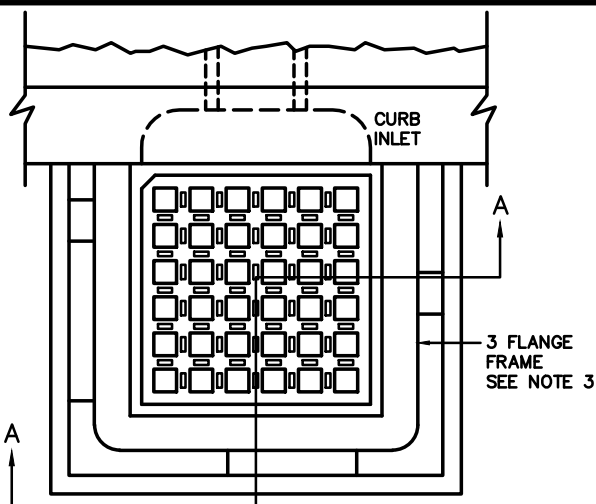

**PLAN VIEW**

**NOTES:**

1. WHERE CURB INLET IS NOT USED THE INSIDE HORIZONTAL DIMENSIONS OF GUTTER INLET TO BE 2 FEET±1" X 2 FEET±1" IN WHICH CASE AND UNLESS OTHERWISE DIRECTED, A STANDARD 4-FLANGE FRAME IS TO BE USED.
2. FRAME AND GRATE SHALL BE EAST JORDAN IRON WORKS CATALOG NOS. 5520M5 & 5523Z (3 FLANGE) OR EQUAL.
3. ADJUST TO GRADE WITH A MINIMUM OF TWO COURSES OF BRICK MASONRY OR REINFORCED CONCRETE GRADE RINGS (NOT SHOWN).
4. ALL EXTERIOR SURFACES OF MANHOLE GRADE ADJUSTMENT COURSES SHALL BE COVERED WITH 1/4" TO 3/8" MASONRY CEMENT PLASTER.

INVERT TO BE CONSTRUCTED OF BRICK AS SHOWN IN DETAILS FOR BRICK GUTTER INLET OR 3000 PSI CEM. CONC.

3000 PSI CEM. CONC. OR PRECAST CONC. SECTIONAL PLATES

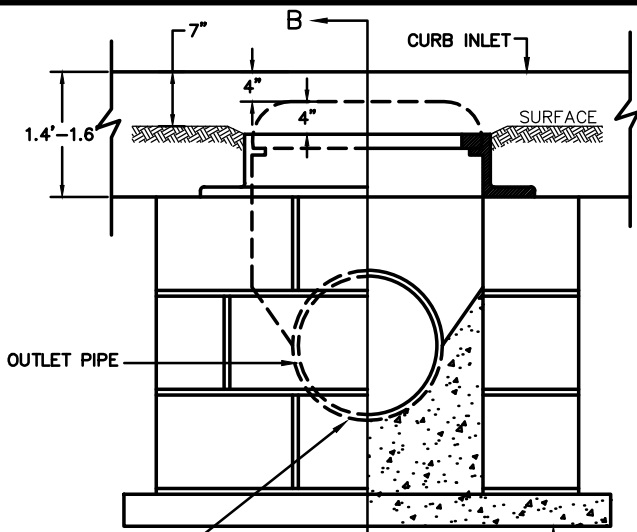

**SECTION A-A**

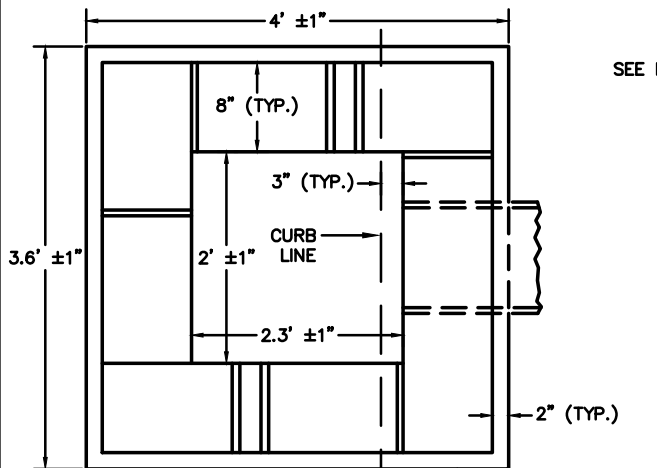

**SECTION C-C**

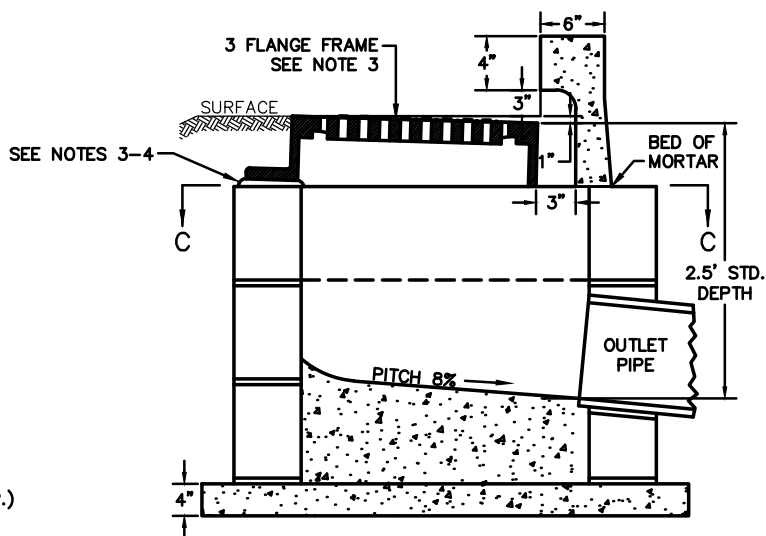

**SECTION B-B**

UNLESS OTHERWISE NOTED, CONSTRUCTION METHODS, MATERIAL REQUIREMENTS AND METHOD OF MEASUREMENT SHALL BE IN ACCORDANCE WITH THE LATEST EDITION OF THE MASSACHUSETTS DEPARTMENT OF TRANSPORTATION (MassDOT) STANDARD SPECIFICATIONS.

ALSO REFERENCE CURRENT MassDOT CONSTRUCTION STANDARD DETAILS.



**DEDHAM DPW  
DESIGN & CONSTRUCTION STANDARDS**

**CONCRETE BLOCK GUTTER INLET**

SCALE: NTS      DATE OF ISSUE: AUGUST 2015

REVISED:

DETAIL NUMBER: SDSW.05

ADJUST TO GRADE WITH A MINIMUM OF TWO COURSES OF BRICK MASONRY OR REINFORCED CONCRETE GRADE RINGS (NOT SHOWN). SEAL WITH 1/4" TO 3/8" MASONRY CEMENT PLASTER

FRAME AND COVER/GRATE SHALL BE EAST JORDAN IRON WORKS CATALOG NO.'S 2110A & 2114Z MARKED "DRAIN", NO.'S 5520M5 & 5523Z, OR APPROVED EQUAL

PRECAST CONCRETE RISER SECTION

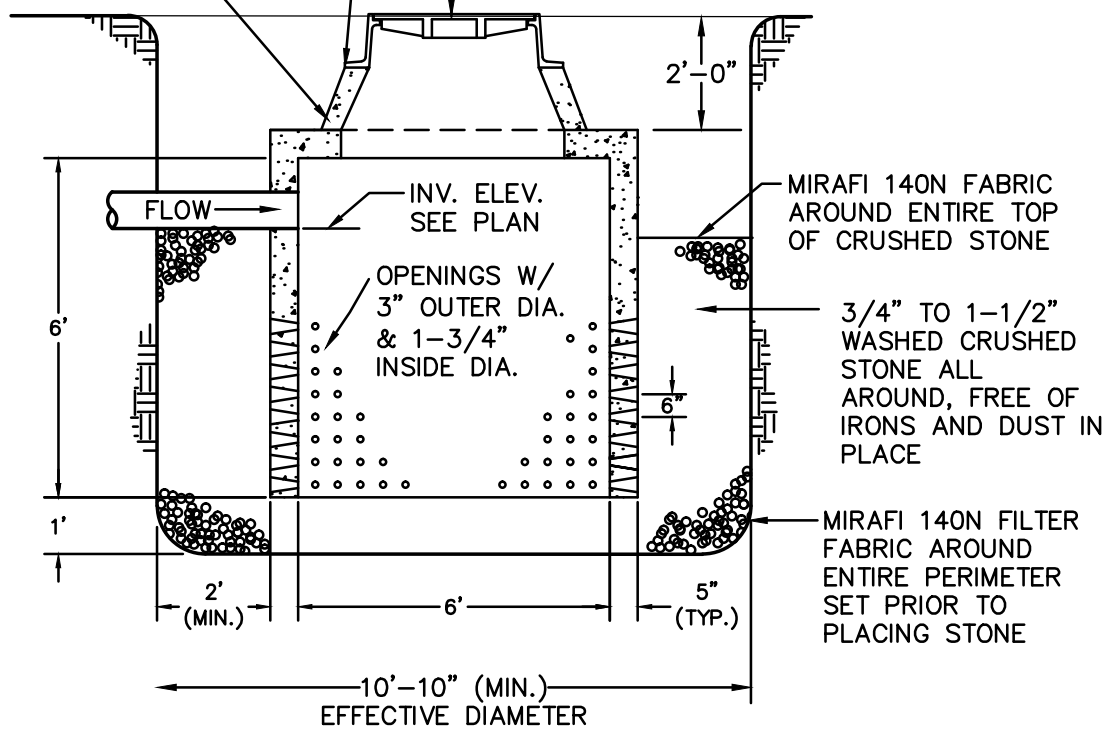

STRUCTURE SHALL BE DESIGNED FOR H-20 LOADING

UNLESS OTHERWISE NOTED, CONSTRUCTION METHODS, MATERIAL REQUIREMENTS AND METHOD OF MEASUREMENT SHALL BE IN ACCORDANCE WITH THE LATEST EDITION OF THE MASSACHUSETTS DEPARTMENT OF TRANSPORTATION (MassDOT) STANDARD SPECIFICATIONS.

ALSO REFERENCE CURRENT MassDOT CONSTRUCTION STANDARD DETAILS.



**DEDHAM DPW  
DESIGN & CONSTRUCTION STANDARDS**

**LEACHING BASIN**

SCALE: NTS	DATE OF ISSUE: AUGUST 2015
REVISED:	
DETAIL NUMBER: SDSW.06	

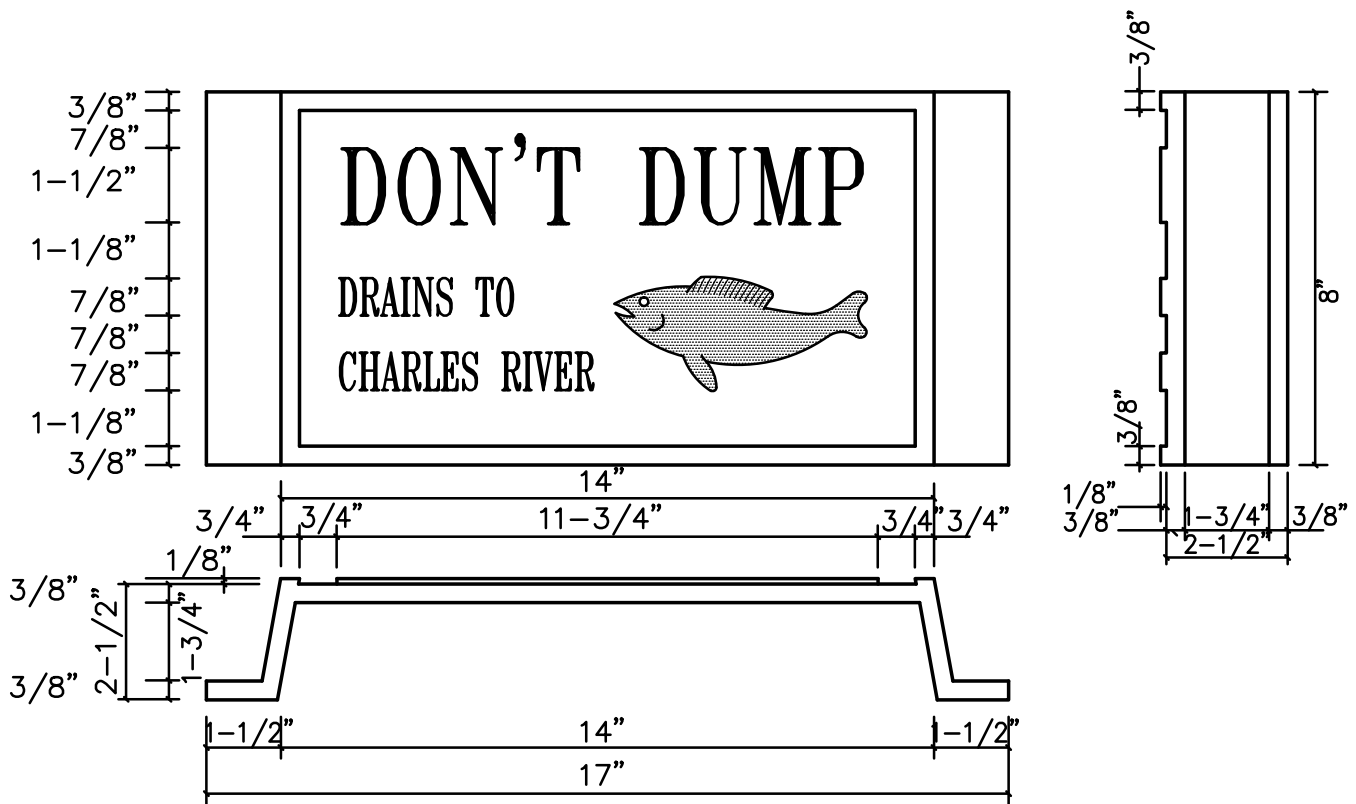

**NOTES:**

1. LETTERING SYMBOLS AND BORDER ALL CUT AT 1/8 HEIGHT.
2. THE SIZE OF THE FISH SHALL BE TO THE SCALE SHOWN ON THE DRAWING.
3. MINIMUM WEIGHT 18 LBS. PER CASTING.
4. CASTING TO BE MADE OF CAST IRON.

UNLESS OTHERWISE NOTED, CONSTRUCTION METHODS, MATERIAL REQUIREMENTS AND METHOD OF MEASUREMENT SHALL BE IN ACCORDANCE WITH THE LATEST EDITION OF THE MASSACHUSETTS DEPARTMENT OF TRANSPORTATION (MassDOT) STANDARD SPECIFICATIONS.

ALSO REFERENCE CURRENT MassDOT CONSTRUCTION STANDARD DETAILS.



**DEDHAM DPW  
DESIGN & CONSTRUCTION STANDARDS**

ENVIRONMENTAL CATCH BASIN PLACARD  
DRAINS TO CHARLES RIVER

SCALE: NTS	DATE OF ISSUE: AUGUST 2015
REVISED:	
DETAIL NUMBER: SDSW.07	



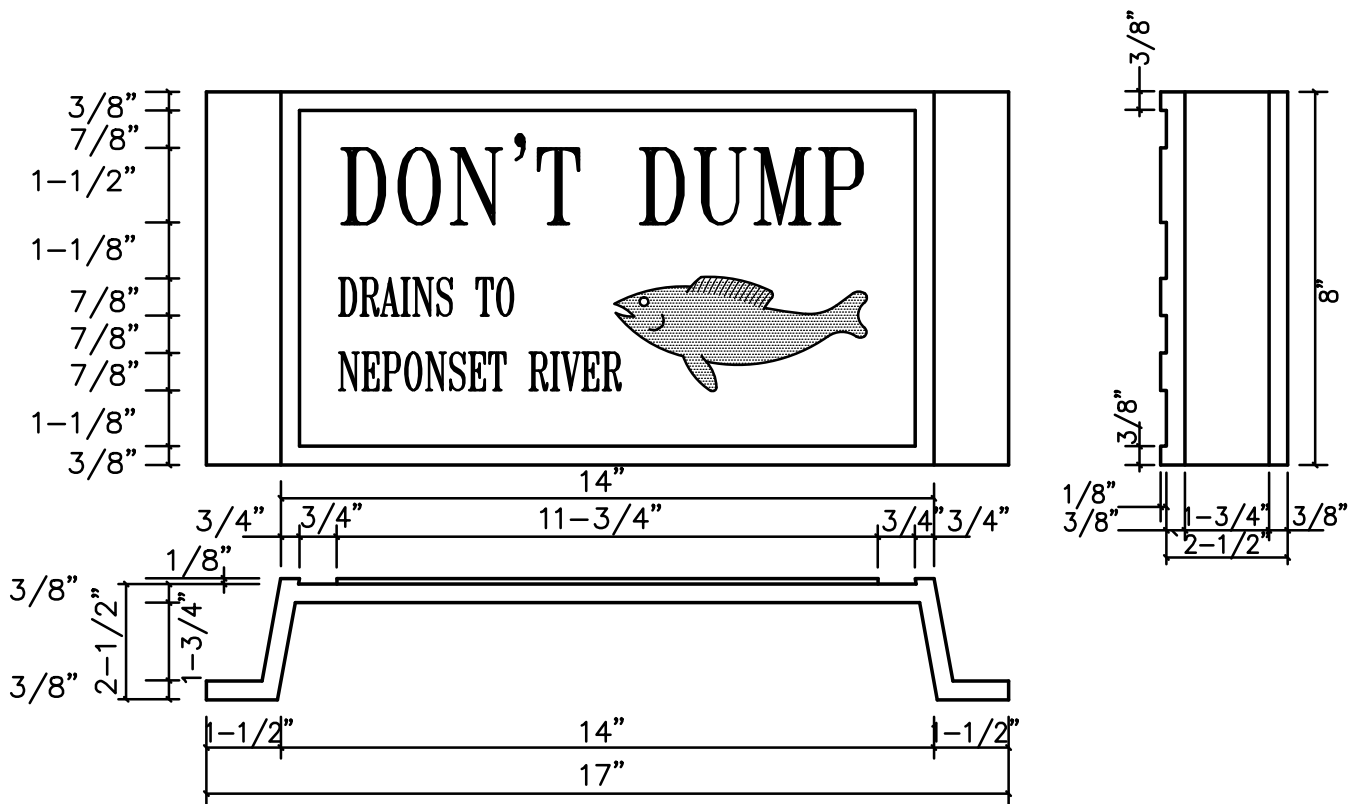

NOTES:

1. LETTERING SYMBOLS AND BORDER ALL CUT AT 1/8 HEIGHT.
2. THE SIZE OF THE FISH SHALL BE TO THE SCALE SHOWN ON THE DRAWING.
3. MINIMUM WEIGHT 18 LBS. PER CASTING.
4. CASTING TO BE MADE OF CAST IRON.

UNLESS OTHERWISE NOTED, CONSTRUCTION METHODS, MATERIAL REQUIREMENTS AND METHOD OF MEASUREMENT SHALL BE IN ACCORDANCE WITH THE LATEST EDITION OF THE MASSACHUSETTS DEPARTMENT OF TRANSPORTATION (MassDOT) STANDARD SPECIFICATIONS.

ALSO REFERENCE CURRENT MassDOT CONSTRUCTION STANDARD DETAILS.



**DEDHAM DPW  
DESIGN & CONSTRUCTION STANDARDS**

ENVIRONMENTAL CATCH BASIN PLACARD  
DRAINS TO NEPONSET RIVER

SCALE: NTS	DATE OF ISSUE: AUGUST 2015
REVISED:	
DETAIL NUMBER: SDSW.08	

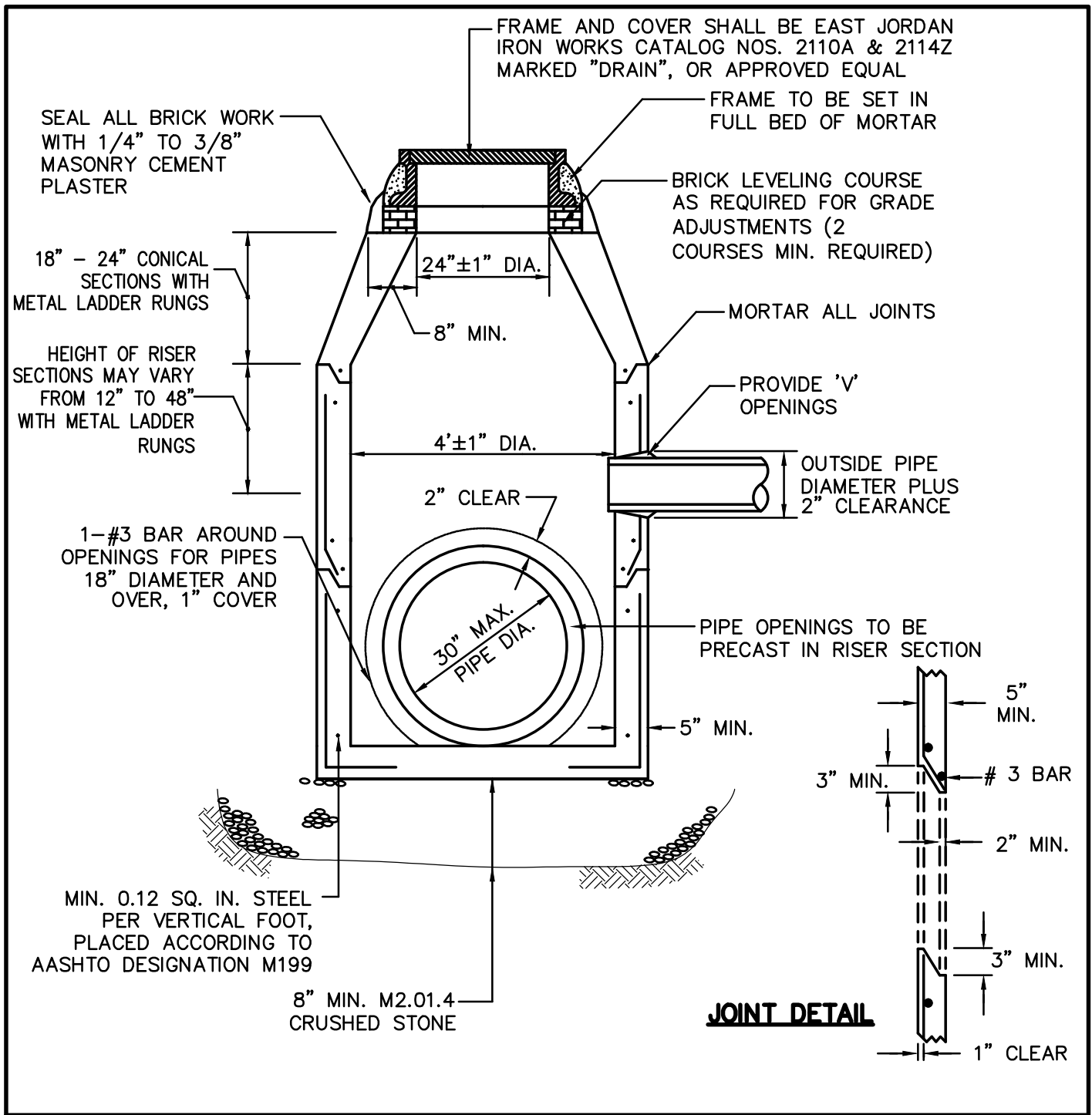

UNLESS OTHERWISE NOTED, CONSTRUCTION METHODS, MATERIAL REQUIREMENTS AND METHOD OF MEASUREMENT SHALL BE IN ACCORDANCE WITH THE LATEST EDITION OF THE MASSACHUSETTS DEPARTMENT OF TRANSPORTATION (MassDOT) STANDARD SPECIFICATIONS.

ALSO REFERENCE CURRENT MassDOT CONSTRUCTION STANDARD DETAILS.



**DEDHAM DPW  
DESIGN & CONSTRUCTION STANDARDS**

PRECAST DRAIN MANHOLE

SCALE: DATE OF ISSUE:  
NTS AUGUST 2015

REVISED:

DETAIL NUMBER:  
SDSW.09

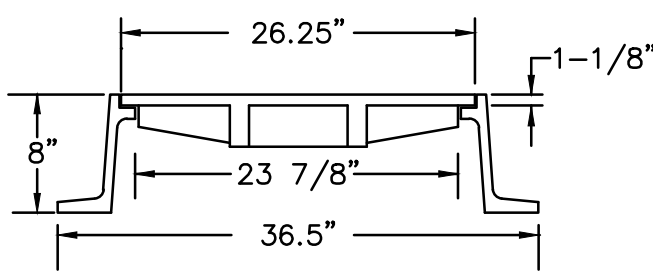
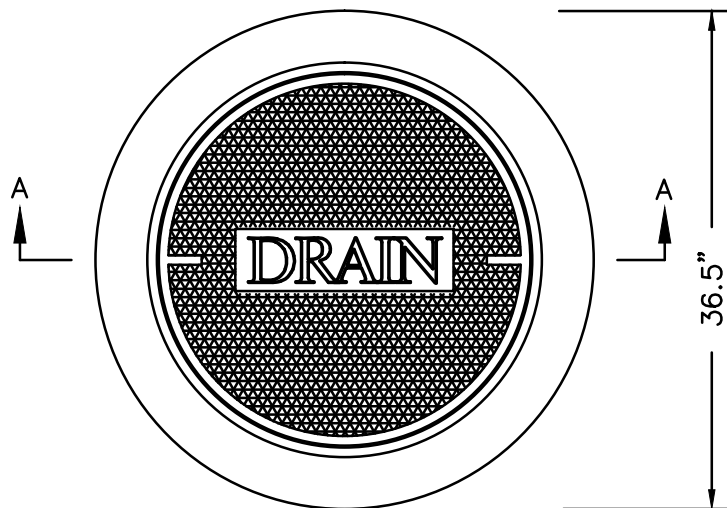

**SECTION A-A**

**NOTE:**

FRAME AND COVER SHALL BE EAST JORDAN IRON WORKS CATALOG NOS. 2110A & 2114Z MARKED "DRAIN", OR APPROVED EQUAL.

UNLESS OTHERWISE NOTED, CONSTRUCTION METHODS, MATERIAL REQUIREMENTS AND METHOD OF MEASUREMENT SHALL BE IN ACCORDANCE WITH THE LATEST EDITION OF THE MASSACHUSETTS DEPARTMENT OF TRANSPORTATION (MassDOT) STANDARD SPECIFICATIONS.

ALSO REFERENCE CURRENT MassDOT CONSTRUCTION STANDARD DETAILS.



**DEDHAM DPW  
DESIGN & CONSTRUCTION STANDARDS**

MANHOLE FRAME & COVER  
MARKED "DRAIN"

SCALE: NTS	DATE OF ISSUE: AUGUST 2015
REVISED:	
DETAIL NUMBER: SDSW.10	

1V:1.5H AND 1V:2H SLOPES								1V:1.5H SLOPES			1V:2H SLOPES			TRENCH EXCAV. FOR 1:2 SLOPE FOR 1'-0" DEPTH CF
D	E	G	H	J	L	N	P	F	CONC MASONRY CY	STEEL LBS	F	CONC MASONRY CY	STEEL LBS	
30	4'-0"	4'-0"	5'-6"	3'-6"	1'-6"	2'-0"	5'-3"	3'-0"	2.60	45	4'-3"	3.16	54	55.16
36	4'-6"	4'-3"	6'-0"	4'-0"	1'-8"	2'-3"	5'-11"	3'-6"	3.35	54	5'-0"	4.15	64	64.36
42	5'-0"	4'-6"	6'-6"	4'-6"	1'-1"	2'-6"	6'-6"	4'-0"	4.20	59	5'-9"	5.25	70	73.70
48	5'-6"	4'-9"	7'-0"	5'-0"	2'-0"	2'-9"	7'-2"	4'-6"	5.19	65	6'-6"	6.50	83	83.96
54	6'-0"	5'-0"	7'-6"	5'-6"	2'-2"	3'-0"	7'-1"	5'-0"	6.26	73	7'-3"	7.88	93	94.46
60	6'-6"	5'-3"	8'-0"	6'-0"	2'-4"	3'-3"	8'-5"	5'-6"	7.43	85	8'-0"	9.37	106	105.30
72	7'-6"	5'-9"	9'-0"	7'-0"	2'-8"	3'-9"	9'-9"	6'-6"	10.25	98	9'-6"	12.99	128	128.92
84	8'-6"	6'-3"	10'-0"	8'-0"	3'-0"	4'-3"	11'-0"	7'-6"	13.49	120	11'-0"	17.32	154	153.86

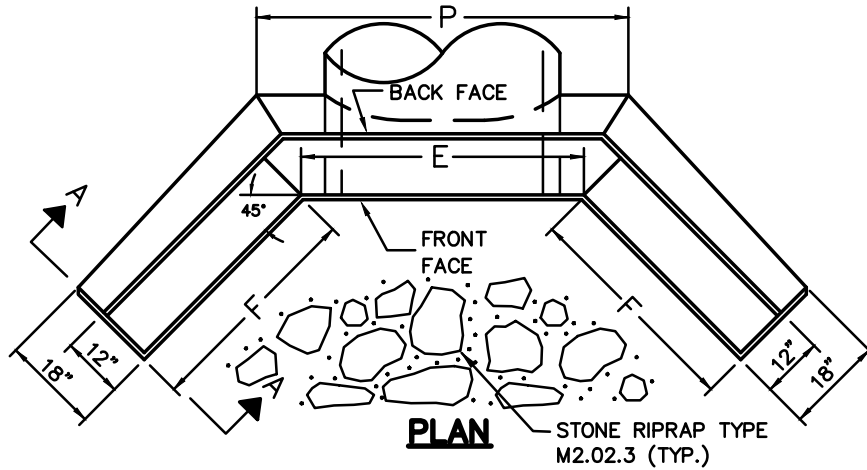

NOTES:  
ALL CONCRETE DIMENSIONS SHOWN ARE MINIMUM.

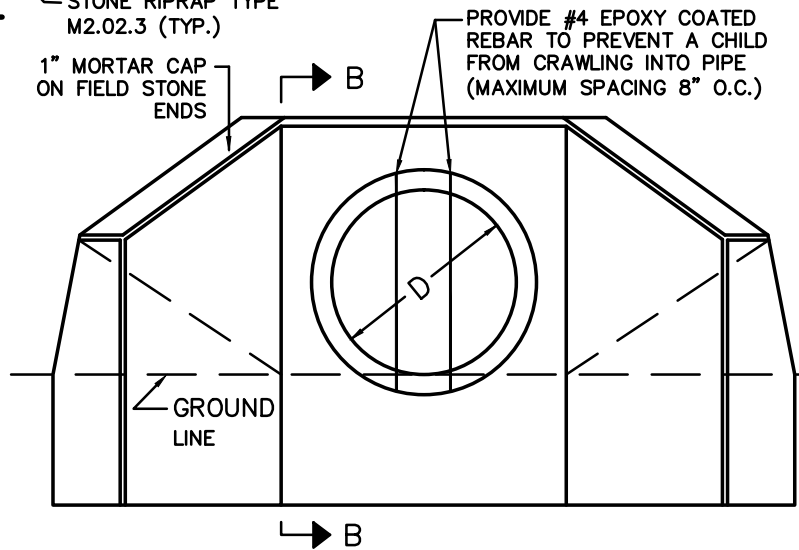
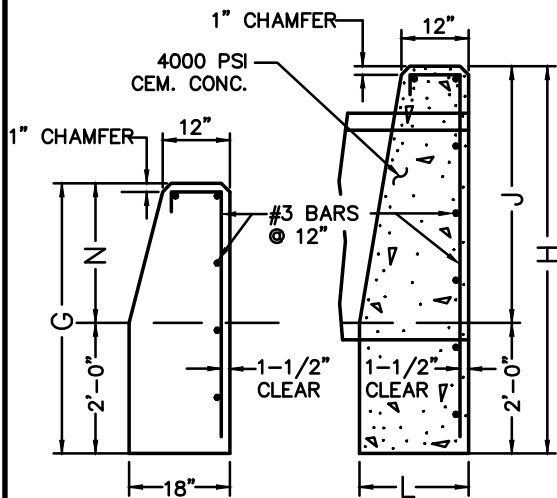

UNLESS OTHERWISE NOTED, CONSTRUCTION METHODS, MATERIAL REQUIREMENTS AND METHOD OF MEASUREMENT SHALL BE IN ACCORDANCE WITH THE LATEST EDITION OF THE MASSACHUSETTS DEPARTMENT OF TRANSPORTATION (MassDOT) STANDARD SPECIFICATIONS.

ALSO REFERENCE CURRENT MassDOT CONSTRUCTION STANDARD DETAILS.



**DEDHAM DPW  
DESIGN & CONSTRUCTION STANDARDS**

CONCRETE OR FIELD STONE MASONRY ENDS

SCALE: NTS  
DATE OF ISSUE: AUGUST 2015

REVISED:

DETAIL NUMBER:  
SDSW.11

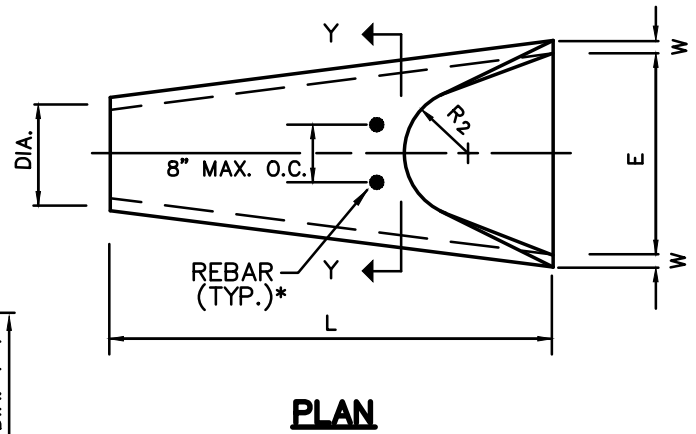
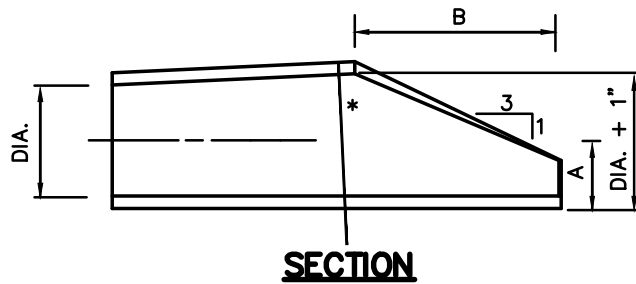

**NOTES:**

1. JOINT TYPE SHALL BE COMPATIBLE WITH MAIN RUN OF PIPE.
2. SEE OUTLET EROSION PROTECTION DETAIL FOR INSTALLATION OF RIPRAP AT FLARED END SECTION.

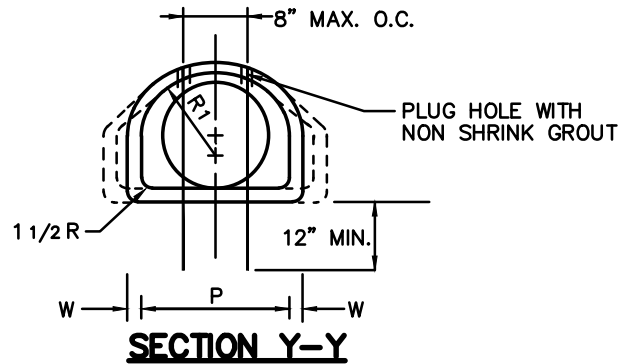

DIAMETER INCHES	W	A	B	D	E	P	DIA. +1"	R1	R2
12"	2"	4"	2'-0"	6'-0"	2'-0"	19 15/16"	13"	10 1/8"	9"
15"	2 1/4"	6"	2'-3"	6'-0"	2'-6"	24 5/16"	16"	12 1/2"	11"
18"	2 1/2"	9"	2'-3"	6'-0"	3'-0"	29"	19"	15 1/2"	12"
21"	2 3/4"	9"	2'-11"	6'-0"	3'-6"	31 5/8"	22"	16 1/8"	13"
24"	3"	9 1/2"	3'-7 1/4"	6'-0"	4'-0"	33 3/16"	25"	16 13/16"	14"
27"	3 1/4"	10 1/2"	4'-0"	6'-0"	4'-6"	36"	28"	18 9/16"	14 1/2"
30"	3 1/2"	12"	4'-6"	6'-0"	5'-0"	37"	31"	18 1/2"	15"
36"	4"	15"	5'-3"	8'-0"	6'-0"	47 13/16"	37"	24 5/16"	20"
42"	4 1/2"	21"	5'-3"	8'-0"	6'-6"	53 7/8"	43"	27 1/2"	22"
48"	5"	24"	6'-0"	8'-0"	7'-0"	56 1/2"	49"	28 1/2"	22"

\* PROVIDE #4 EPOXY COATED REBAR TO PREVENT A CHILD FROM CRAWLING INTO PIPE (MAXIMUM SPACING 8" O.C.)

UNLESS OTHERWISE NOTED, CONSTRUCTION METHODS, MATERIAL REQUIREMENTS AND METHOD OF MEASUREMENT SHALL BE IN ACCORDANCE WITH THE LATEST EDITION OF THE MASSACHUSETTS DEPARTMENT OF TRANSPORTATION (MassDOT) STANDARD SPECIFICATIONS.

ALSO REFERENCE CURRENT MassDOT CONSTRUCTION STANDARD DETAILS.



**DEDHAM DPW  
DESIGN & CONSTRUCTION STANDARDS**

**REINFORCED CONCRETE FLARED END SECTION**

SCALE: NTS      DATE OF ISSUE: AUGUST 2015

REVISED:

DETAIL NUMBER: SDSW.12

**PLAN VIEW**

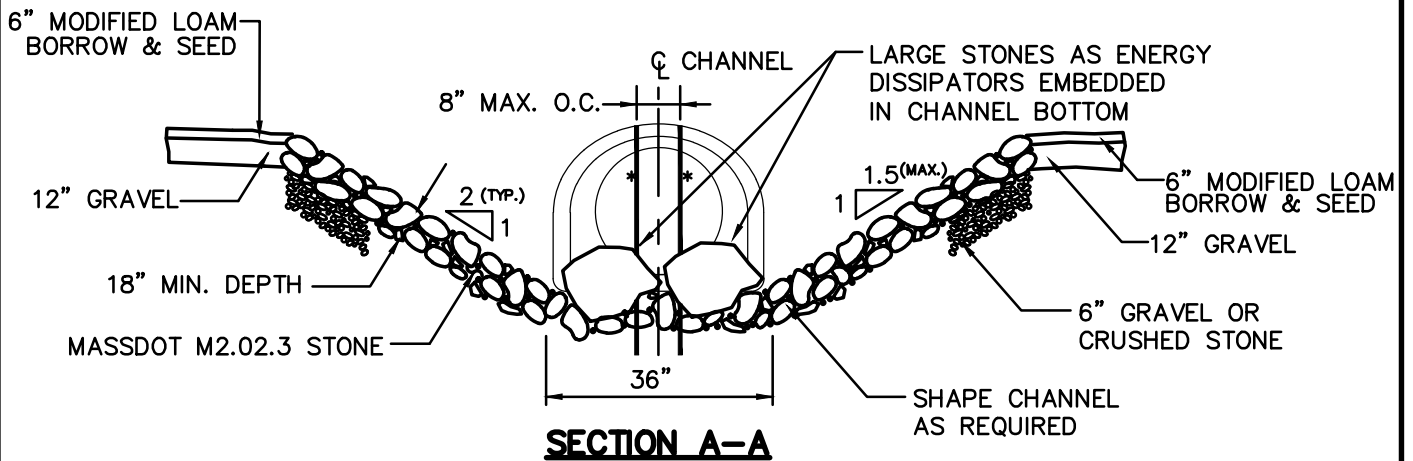
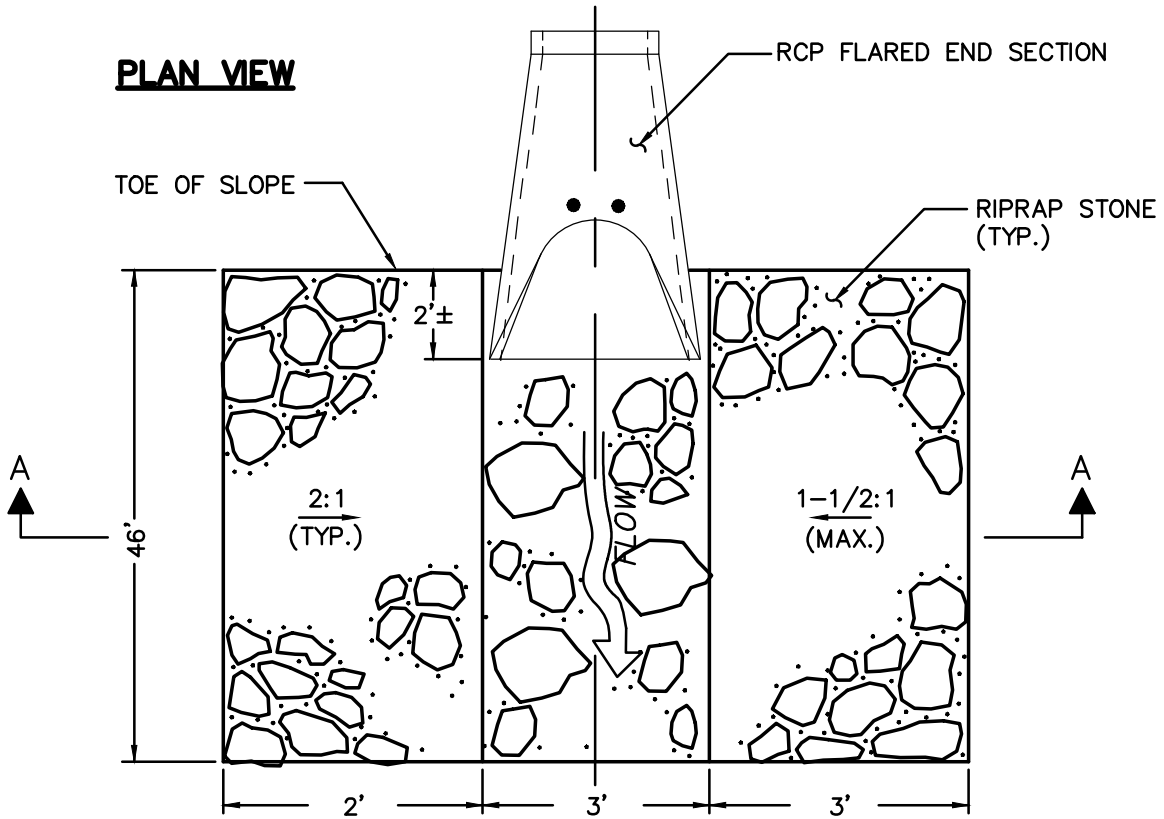

\* PROVIDE #4 EPOXY COATED REBAR TO PREVENT A CHILD FROM CRAWLING INTO PIPE (MAXIMUM SPACING 8" O.C.)

UNLESS OTHERWISE NOTED, CONSTRUCTION METHODS, MATERIAL REQUIREMENTS AND METHOD OF MEASUREMENT SHALL BE IN ACCORDANCE WITH THE LATEST EDITION OF THE MASSACHUSETTS DEPARTMENT OF TRANSPORTATION (MassDOT) STANDARD SPECIFICATIONS.

ALSO REFERENCE CURRENT MassDOT CONSTRUCTION STANDARD DETAILS.



**DEDHAM DPW  
DESIGN & CONSTRUCTION STANDARDS**

**RIPRAP VELOCITY DISSIPATOR**

SCALE: NTS      DATE OF ISSUE: AUGUST 2015

REVISED:

DETAIL NUMBER: SDSW.13

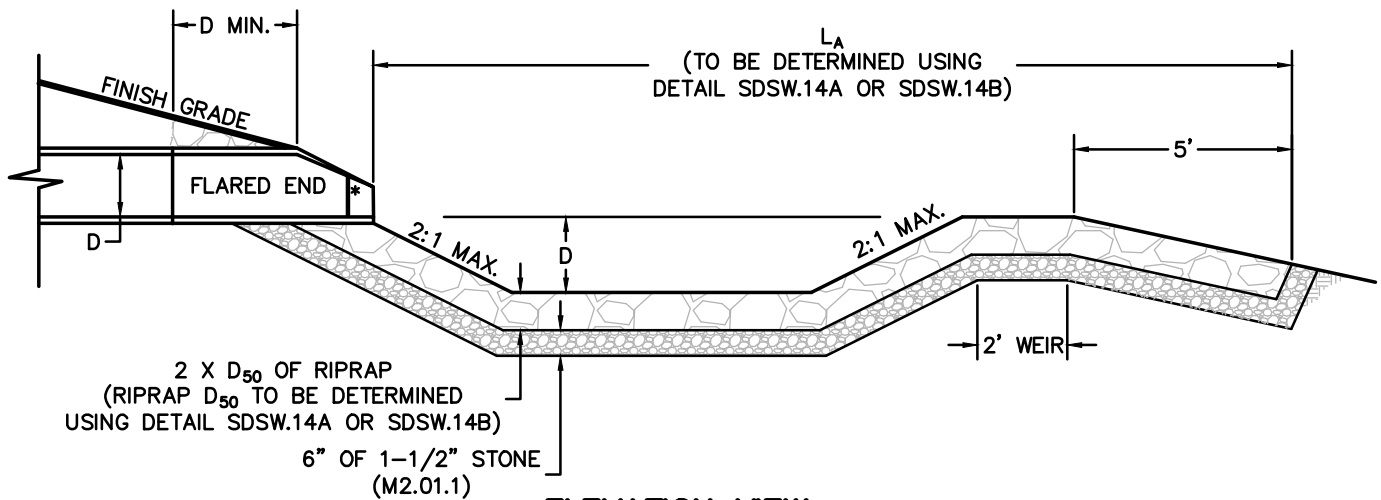

**ELEVATION VIEW**

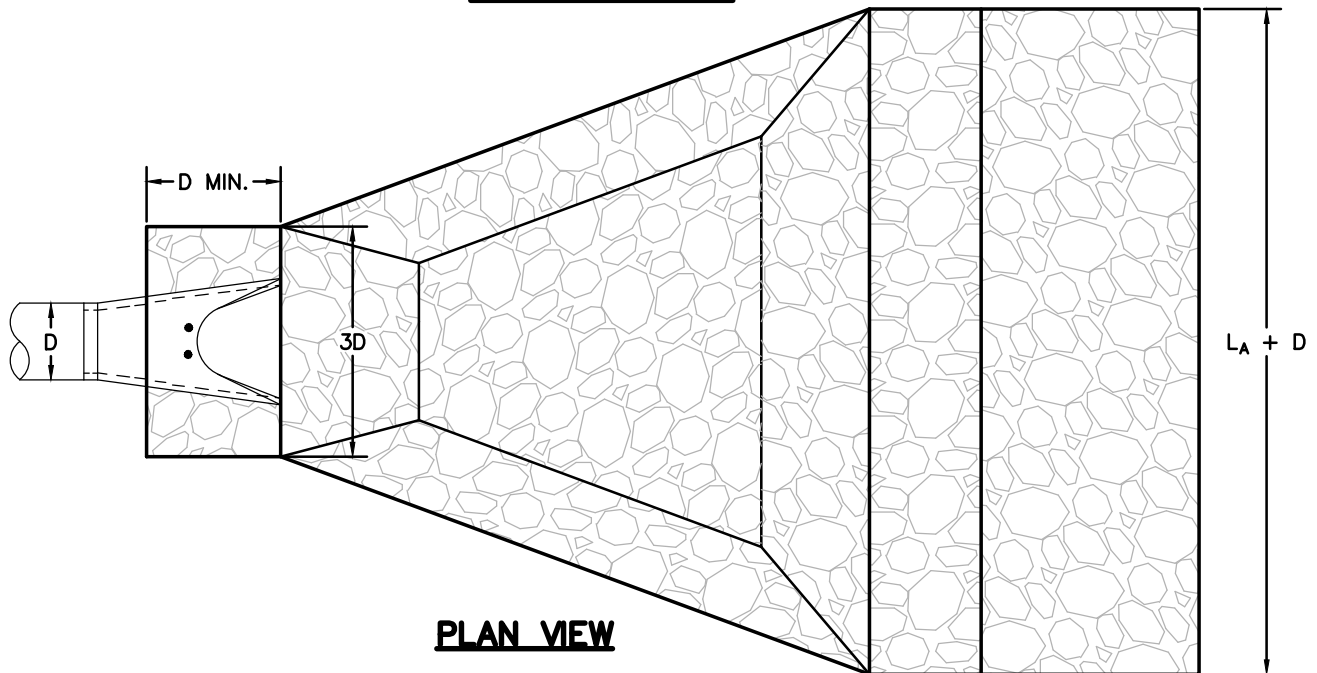

**PLAN VIEW**

**NOTES:**

- \* PROVIDE #4 EPOXY COATED REBAR TO PREVENT A CHILD FROM CRAWLING INTO PIPE (MAXIMUM SPACING 8" O.C.)
- 1. THE TABLES IN THE FOLLOWING DETAILS ASSUME PIPE IS FLOWING FULL. FOR PARTIAL FLOW OR USE WITH OPEN CHANNELS, USE VELOCITY AND REFER TO CURVES PROVIDED IN "DESIGN GUIDE MD #6, RIPRAP DESIGN METHODS" (NRCS, JAN 2004).

UNLESS OTHERWISE NOTED, CONSTRUCTION METHODS, MATERIAL REQUIREMENTS AND METHOD OF MEASUREMENT SHALL BE IN ACCORDANCE WITH THE LATEST EDITION OF THE MASSACHUSETTS DEPARTMENT OF TRANSPORTATION (MassDOT) STANDARD SPECIFICATIONS.

ALSO REFERENCE CURRENT MassDOT CONSTRUCTION STANDARD DETAILS.



**DEDHAM DPW  
DESIGN & CONSTRUCTION STANDARDS**

**STONE OUTLET PROTECTION**

SCALE: NTS	DATE OF ISSUE: AUGUST 2015
REVISED:	
DETAIL NUMBER: SDSW.14	

**OUTLET PROTECTION FOR PIPE FLOWING UNDER LOW  
TAILWATER CONDITION ( $T_w < 0.5$  PIPE DIAM.)**

		MEDIAN RIPRAP SIZE, $D_{50}$ (INCHES)												
		PIPE DIAMETER (INCHES)												
		12	15	18	21	24	27	30	36	42	48	54	60	
DISCHARGE (CUBIC FEET PER SECOND, CFS)	3	6												
	5	6												
	8	6	6											
	12	8	6	6										
	15	8	6	8	6									
	20		10	10	6	6								
	25		12	12	6	6								
	30				8	8	6							
	40				12	10	8	6						
	50				16	12	10	8	6					
	60				18	16	12	10	8					
	70					18	15	12	8					
	80					20	16	15	10	8				
	100						20	18	12	10				
	125							24	20	16	12	10		
150								24	20	16	12	10		
200									24	20	18	15	12	

**SOURCES:**

- USDA-SCS
- MAINE DEP

		MINIMUM LENGTH OF APRON, $L_a$ (FEET)												
		PIPE DIAMETER (INCHES)												
		12	15	18	21	24	27	30	36	42	48	54	60	
DISCHARGE (CUBIC FEET PER SECOND, CFS)	3	8												
	5	8												
	8	11	10											
	10	14	12	10										
	15	18	16	14	12									
	20		18	18	16	12								
	30			22	20	18	16							
	40			26	24	24	20	18						
	50				26	26	24	22	18					
	70					30	30	28	25					
	100							36	36	33	27			
	150								42	42	42	38	33	28
	200									48	45	42	37	32

UNLESS OTHERWISE NOTED, CONSTRUCTION METHODS, MATERIAL REQUIREMENTS AND METHOD OF MEASUREMENT SHALL BE IN ACCORDANCE WITH THE LATEST EDITION OF THE MASSACHUSETTS DEPARTMENT OF TRANSPORTATION (MassDOT) STANDARD SPECIFICATIONS.

ALSO REFERENCE CURRENT MassDOT CONSTRUCTION STANDARD DETAILS.



**DEDHAM DPW  
DESIGN & CONSTRUCTION STANDARDS**

OUTLET PROTECTION TABLE FOR  
LOW TAILWATER CONDITION

SCALE: NTS      DATE OF ISSUE:  
AUGUST 2015

REVISED:

DETAIL NUMBER:  
SDSW.14A



**OUTLET PROTECTION FOR PIPE FLOWING UNDER HIGH  
TAILWATER CONDITION ( $T_w \geq 0.5$  PIPE DIAM.)**

		MEDIAN RIPRAP SIZE, $D_{50}$ (INCHES)													
		PIPE DIAMETER (INCHES)													
		12	15	18	21	24	27	30	36	42	48	54	60		
DISCHARGE (CUBIC FEET PER SECOND, CFS)	4	6													
	6	6													
	8	6	6												
	10	6	6												
	14	8	6	6											
	20		8	6	6										
	25		10	8	6										
	35			10	8	6									
	50				12	9	6	6							
	60				15	12	9	6							
	80					18	12	10	6						
	100						15	12	8	6					
	125							18	12	6					
	150								15	10	6				
	200									21	15	10	6	6	
300										24	18	15	9		
400											24	21	15		

- SOURCES:
- USDA-SCS
  - MAINE DEP

		MINIMUM LENGTH OF APRON, $L_A$ (FEET)												
		PIPE DIAMETER (INCHES)												
		12	15	18	21	24	27	30	36	42	48	54	60	
DISCHARGE (CUBIC FEET PER SECOND, CFS)	4	8												
	6	18												
	8	26	13											
	10	32	20	9										
	15		33	22	10									
	20		42	34	22	8								
	40			60	54	44	32	20						
	50				64	55	45	34						
	70					74	65	55	30					
	100						86	80	58	32				
	150								90	70	45			
	200									112	96	74	50	22
	300											116	98	74
	400													110

UNLESS OTHERWISE NOTED, CONSTRUCTION METHODS, MATERIAL REQUIREMENTS AND METHOD OF MEASUREMENT SHALL BE IN ACCORDANCE WITH THE LATEST EDITION OF THE MASSACHUSETTS DEPARTMENT OF TRANSPORTATION (MassDOT) STANDARD SPECIFICATIONS.

ALSO REFERENCE CURRENT MassDOT CONSTRUCTION STANDARD DETAILS.



**DEDHAM DPW  
DESIGN & CONSTRUCTION STANDARDS**

OUTLET PROTECTION TABLE FOR  
HIGH TAILWATER CONDITION

SCALE: NTS      DATE OF ISSUE:  
AUGUST 2015

REVISED:

DETAIL NUMBER:  
SDSW.14B

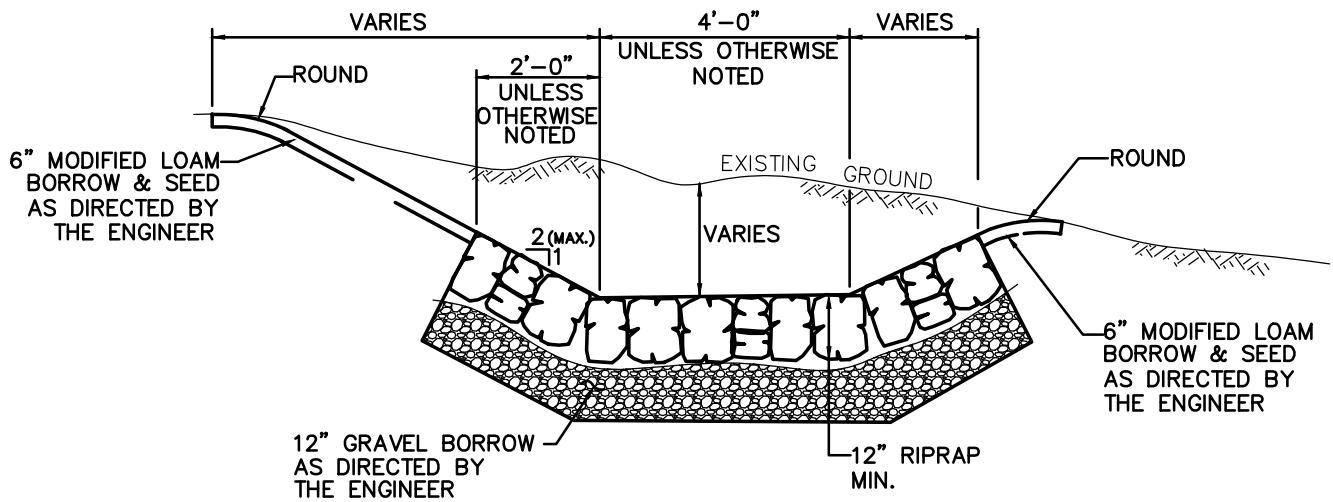

UNLESS OTHERWISE NOTED, CONSTRUCTION METHODS, MATERIAL REQUIREMENTS AND METHOD OF MEASUREMENT SHALL BE IN ACCORDANCE WITH THE LATEST EDITION OF THE MASSACHUSETTS DEPARTMENT OF TRANSPORTATION (MassDOT) STANDARD SPECIFICATIONS.

ALSO REFERENCE CURRENT MassDOT CONSTRUCTION STANDARD DETAILS.



**DEDHAM DPW  
DESIGN & CONSTRUCTION STANDARDS**

RIPRAP DITCH

SCALE: NTS	DATE OF ISSUE: AUGUST 2015
---------------	-------------------------------

REVISED:

DETAIL NUMBER: SDSW.15
---------------------------

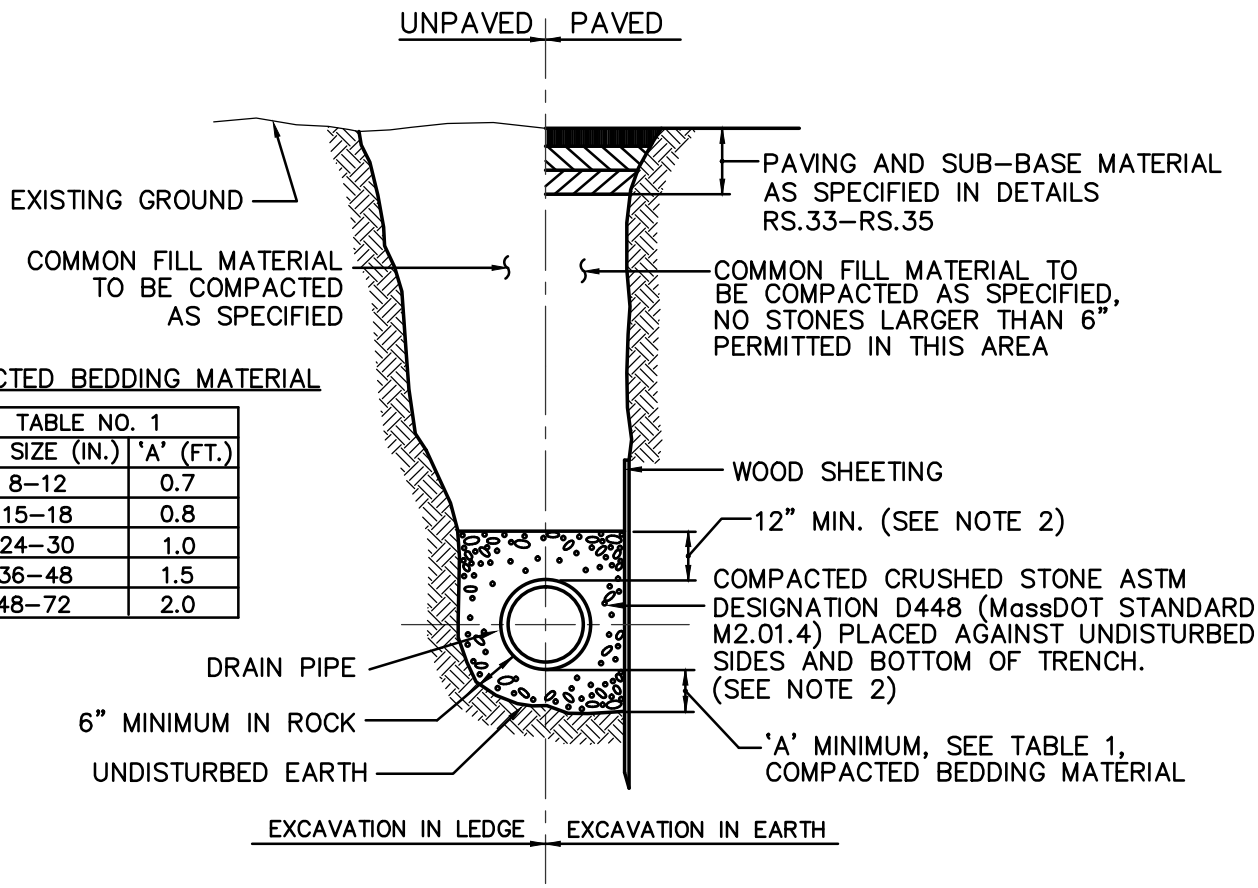

**COMPACTED BEDDING MATERIAL**

TABLE NO. 1	
PIPE SIZE (IN.)	'A' (FT.)
8-12	0.7
15-18	0.8
24-30	1.0
36-48	1.5
48-72	2.0

**NOTES:**

1. SHEETING, WHEN REQUIRED, TO BE CUT OFF AT LEAST 5 FEET BELOW STREET AND A MINIMUM OF 1 FOOT ABOVE TOP OF PIPE. WOOD SHEETING DRIVEN BELOW MID-DIAMETER OF THE PIPE SHALL BE LEFT IN PLACE. STEEL SHEETING DRIVEN BELOW MID-DIAMETER MAY BE WITHDRAWN IF APPROVED IN WRITING BY THE ENGINEER. FOR PVC PIPE ALL SHEETING DRIVEN BELOW MID-DIAMETER SHALL BE LEFT IN PLACE.
2. WHEN APPROVED BY THE ENGINEER FOR NON-PLASTIC PIPES, SELECTED GRAVEL FILL MATERIAL MAY BE USED FROM SPRINGLINE OF PIPE TO 12" ABOVE TOP OF PIPE. NO STONES LARGER THAN 2 INCHES IN ANY DIMENSION WILL BE PERMITTED IN THIS AREA - MassDOT MATERIAL STANDARD M1.03.0 TYPE C.
3. TRENCHES LOCATED ON THE ROAD SHOULDER SHALL BE TREATED THE SAME AS OFF-ROAD EXCEPT FOR PAVING. (SEE TRENCH RESTORATION DETAILS RS.33-35).
4. PROVIDE AT LEAST ONE ANTI-SEEP COLLAR IN GRAVEL BEDDING BETWEEN EACH MANHOLE WHERE DIRECTED, OR EVERY 300 FEET, WHICHEVER IS LESS. SEE ANTI-SEEP COLLAR DETAIL SDSW.17.
5. BEDDING MATERIAL FOR PLASTIC PIPE SHALL MEET THE REQUIREMENTS OF ASTM D2321 CLASS I OR CLASS II EMBEDMENT MATERIALS.

UNLESS OTHERWISE NOTED, CONSTRUCTION METHODS, MATERIAL REQUIREMENTS AND METHOD OF MEASUREMENT SHALL BE IN ACCORDANCE WITH THE LATEST EDITION OF THE MASSACHUSETTS DEPARTMENT OF TRANSPORTATION (MassDOT) STANDARD SPECIFICATIONS.

ALSO REFERENCE CURRENT MassDOT CONSTRUCTION STANDARD DETAILS.



**DEDHAM DPW  
DESIGN & CONSTRUCTION STANDARDS**

DRAINAGE TRENCH  
PVC, HDPE, OR RCP

SCALE: NTS	DATE OF ISSUE: AUGUST 2015
REVISED:	
DETAIL NUMBER: SDSW.16	

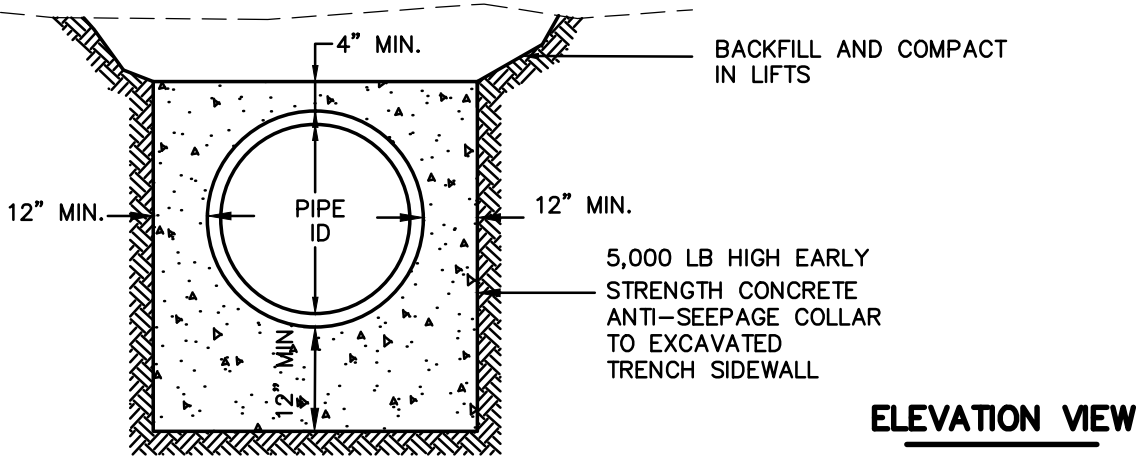

**ELEVATION VIEW**

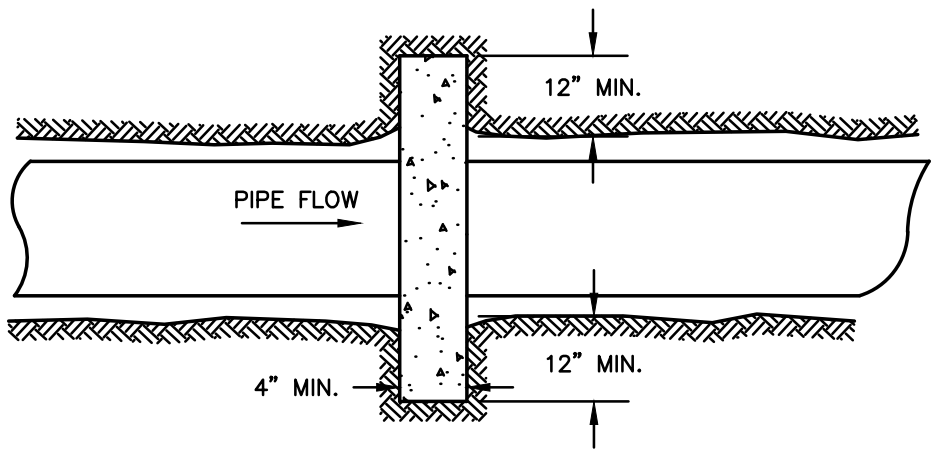

**PLAN VIEW**

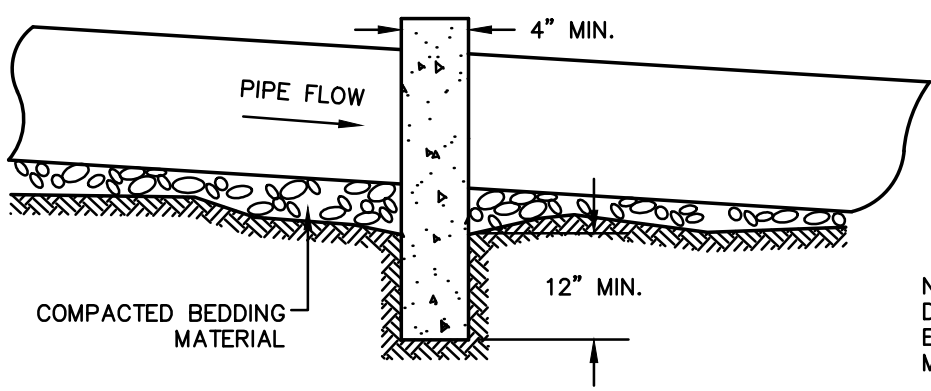

**PROFILE VIEW**

NOTE: STRUCTURE MUST BE DESIGNED BY A PROFESSIONAL ENGINEER REGISTERED IN MASSACHUSETTS

UNLESS OTHERWISE NOTED, CONSTRUCTION METHODS, MATERIAL REQUIREMENTS AND METHOD OF MEASUREMENT SHALL BE IN ACCORDANCE WITH THE LATEST EDITION OF THE MASSACHUSETTS DEPARTMENT OF TRANSPORTATION (MassDOT) STANDARD SPECIFICATIONS.

ALSO REFERENCE CURRENT MassDOT CONSTRUCTION STANDARD DETAILS.



**DEDHAM DPW  
DESIGN & CONSTRUCTION STANDARDS**

**STORM DRAIN ANTI-SEEP COLLAR**

SCALE: NTS	DATE OF ISSUE: AUGUST 2015
REVISED:	
DETAIL NUMBER: SDSW.17	

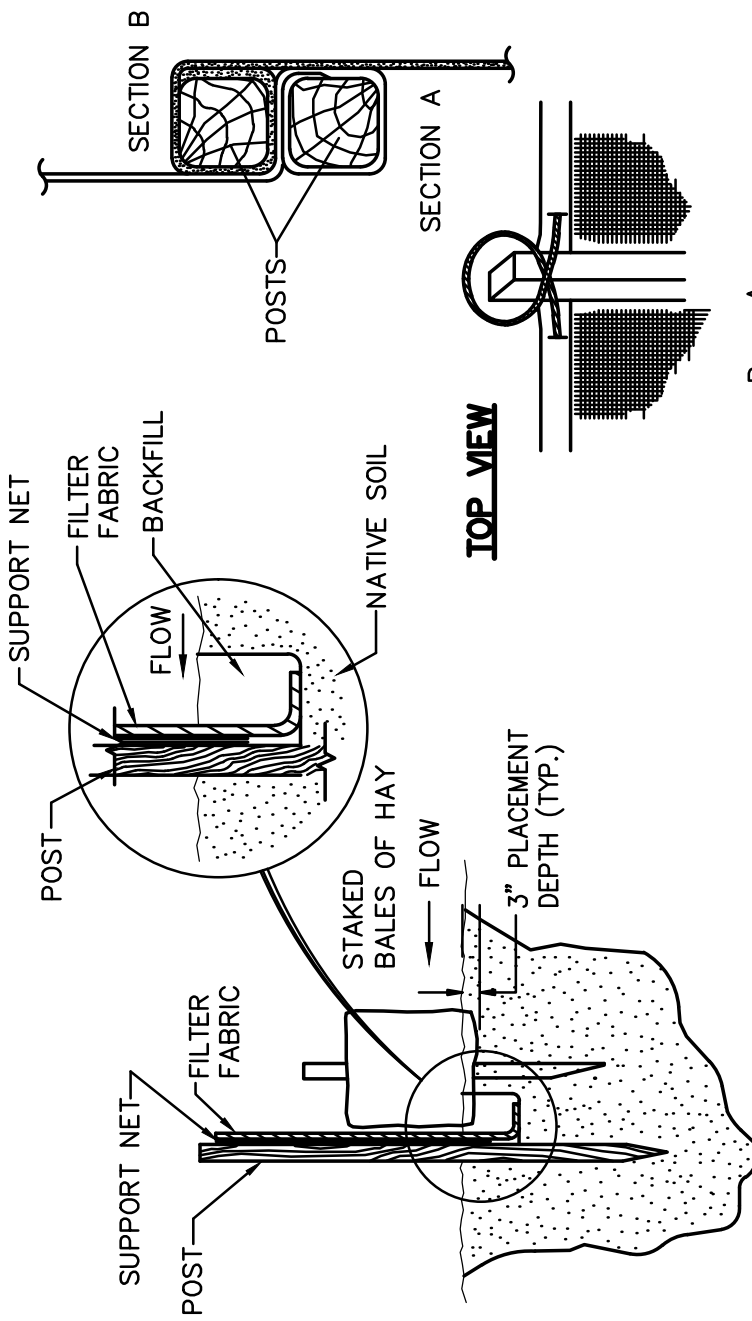

**PLACEMENT OF ENVIRO-FENCE INTO TOE-IN TRENCH**

- DRIVE THE POSTS INTO THE GROUND UNTIL THE BOTTOM OF THE INDUSTRIAL NETTING IS APPROXIMATELY 2" INTO THE TRENCH.
- LAY THE BOTTOM 6" OF SEDIMENTATION CONTROL FABRIC INTO THE TRENCH. (THE SAME PRINCIPLE MAY BE EMPLOYED SIMPLY BY LAYING THE EXCESS FABRIC ON THE GROUND AND PILING FILL AT THE BASE.)
- BACKFILL THE TRENCH WITH NATIVE SOIL AND COMPACT, MAKING SURE THE FABRIC TOE IS IN PLACE.

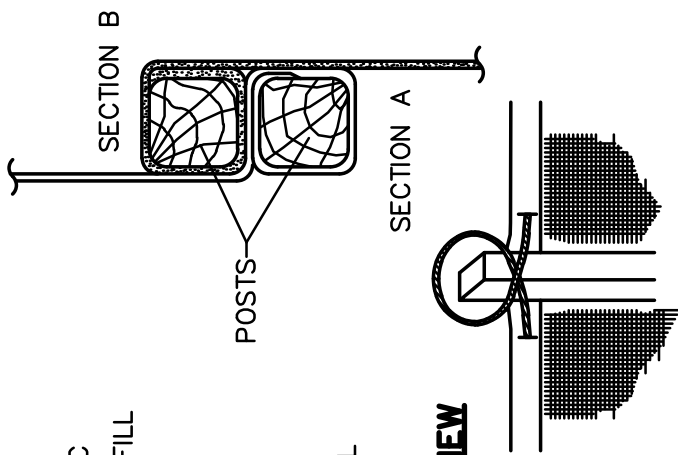

**TOP VIEW**

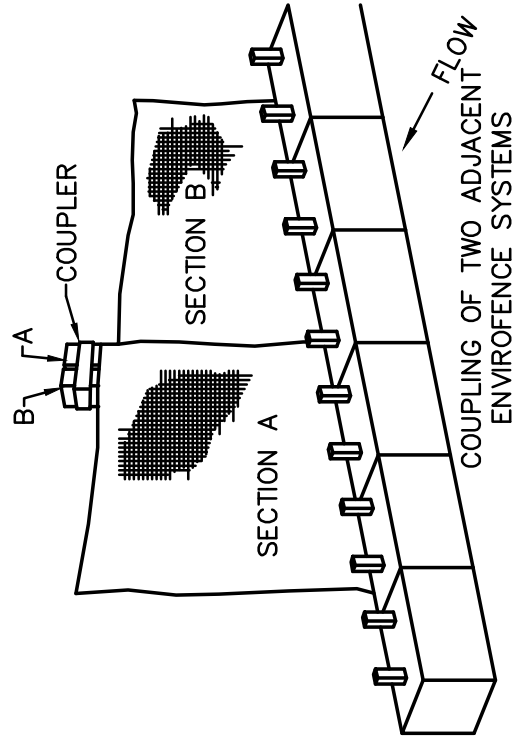

**FRONT VIEW**

UNLESS OTHERWISE NOTED, CONSTRUCTION METHODS, MATERIAL REQUIREMENTS AND METHOD OF MEASUREMENT SHALL BE IN ACCORDANCE WITH THE LATEST EDITION OF THE MASSACHUSETTS DEPARTMENT OF TRANSPORTATION (MassDOT) STANDARD SPECIFICATIONS.

ALSO REFERENCE CURRENT MassDOT CONSTRUCTION STANDARD DETAILS.



**DEDHAM DPW  
DESIGN & CONSTRUCTION STANDARDS**

SILT FENCE

SCALE: NTS	DATE OF ISSUE: AUGUST 2015
REVISED:	
DETAIL NUMBER:	SDSW.18

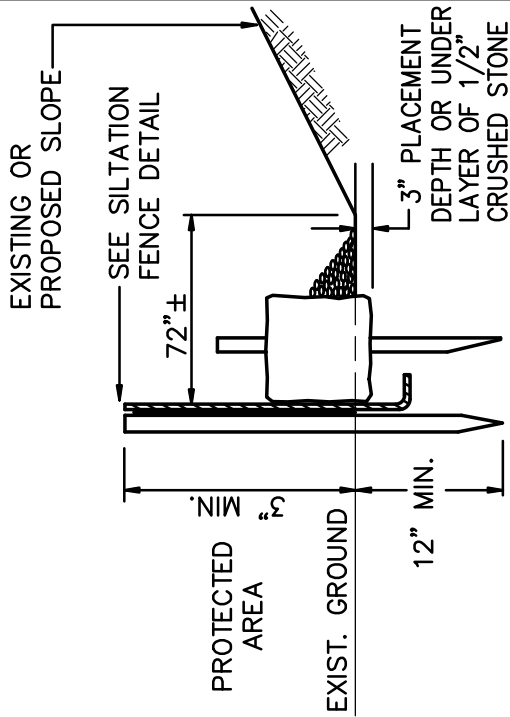

**ELEVATION (TYPE 'C')**

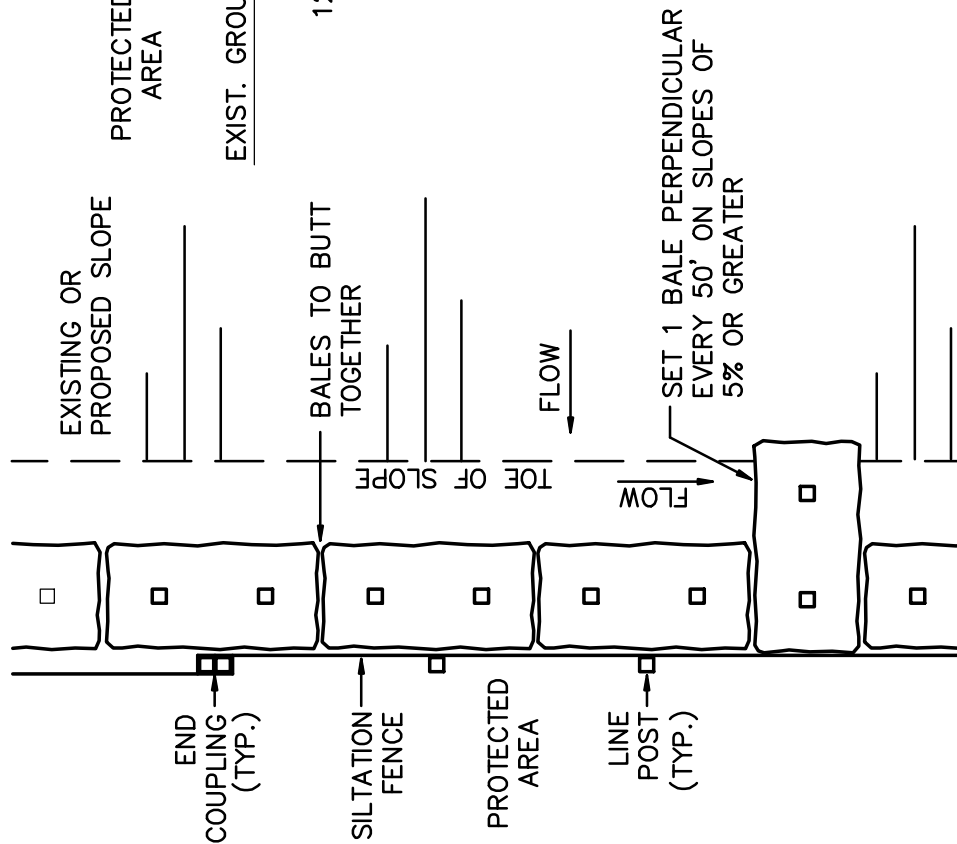

**PLAN (TYPE 'C')**

UNLESS OTHERWISE NOTED, CONSTRUCTION METHODS, MATERIAL REQUIREMENTS AND METHOD OF MEASUREMENT SHALL BE IN ACCORDANCE WITH THE LATEST EDITION OF THE MASSACHUSETTS DEPARTMENT OF TRANSPORTATION (MassDOT) STANDARD SPECIFICATIONS.

ALSO REFERENCE CURRENT MassDOT CONSTRUCTION STANDARD DETAILS.



**DEDHAM DPW  
DESIGN & CONSTRUCTION STANDARDS**

BALES OF HAY & SILT FENCE

SCALE: NTS	DATE OF ISSUE: AUGUST 2015
REVISED:	
DETAIL NUMBER: SDSW.19	

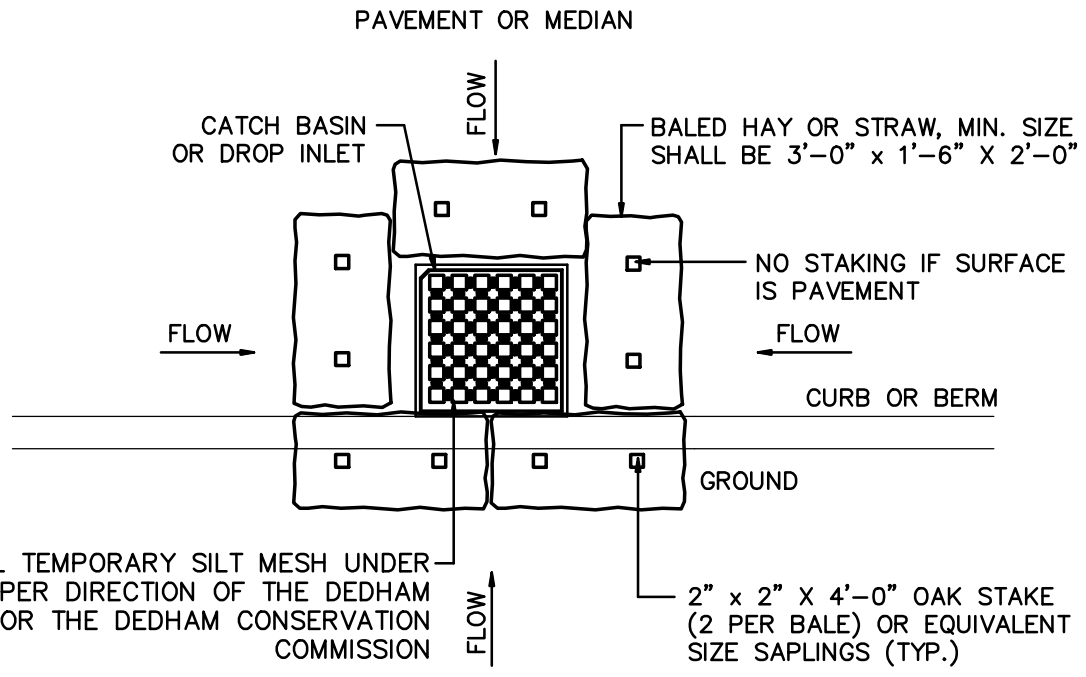

INSTALL TEMPORARY SILT MESH UNDER GRATE PER DIRECTION OF THE DEDHAM DPW OR THE DEDHAM CONSERVATION COMMISSION

**PLAN**

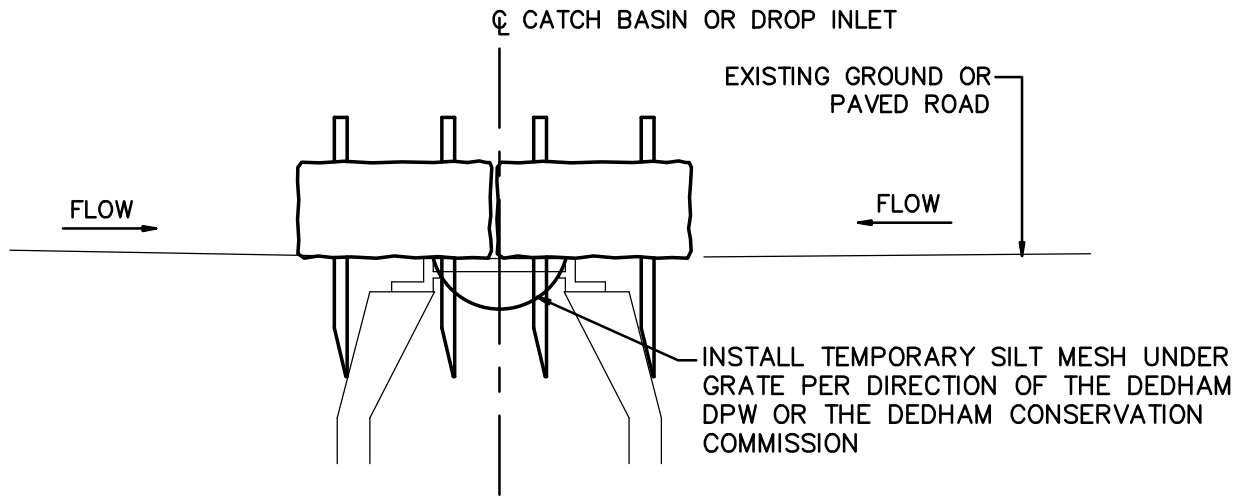

**SECTION**

UNLESS OTHERWISE NOTED, CONSTRUCTION METHODS, MATERIAL REQUIREMENTS AND METHOD OF MEASUREMENT SHALL BE IN ACCORDANCE WITH THE LATEST EDITION OF THE MASSACHUSETTS DEPARTMENT OF TRANSPORTATION (MassDOT) STANDARD SPECIFICATIONS.

ALSO REFERENCE CURRENT MassDOT CONSTRUCTION STANDARD DETAILS.



**DEDHAM DPW  
DESIGN & CONSTRUCTION STANDARDS**

**DRAIN INLET PROTECTION**

SCALE: NTS	DATE OF ISSUE: AUGUST 2015
REVISED:	
DETAIL NUMBER: SDSW.20	

# SANITARY SEWER

<u>DESCRIPTION</u>	<u>DETAIL NUMBER</u>
GENERAL NOTES FOR PIPE TRENCHES	SS.01
TRENCH SECTION FOR SEWER PIPE (18-INCH DIAMETER AND SMALLER)	SS.02
TRENCH SECTION IN UNSUITABLE MATERIAL	SS.03
MANHOLE RISER WITH ECCENTRIC CONE TOP	SS.04
PRECAST REINFORCED CONCRETE MANHOLE BASE FOR SEWERS	SS.05
MANHOLE FRAME & COVER MARKED "SEWER"	SS.06
WATERTIGHT RESILIENT CONNECTOR FOR CONNECTING PIPES TO PRECAST CONCRETE MANHOLES	SS.07
NON-SHRINK MORTAR JOINTS FOR CONNECTING PIPES TO BRICK OR BLOCK MASONRY MANHOLES	SS.08
PRECAST REINFORCED CONCRETE SEWER CHIMNEY	SS.09
TYPICAL SONOTUBE CAST-IN-PLACE SEWER CHIMNEY	SS.10
RECONSTRUCTED BUILDING CONNECTION	SS.11
ABANDON EXISTING MANHOLES/CESSPOOLS	SS.12
TYPICAL SEWER CLEANOUT DETAIL	SS.13
SEWER CLEANOUT DETAIL WITHIN 10' OF BUILDING FOUNDATION	SS.14



**DEDHAM DPW  
DESIGN & CONSTRUCTION STANDARDS**

DETAIL INDEX  
SANITARY SEWER

SCALE: NTS	DATE OF ISSUE: AUGUST 2015
---------------	-------------------------------

REVISED:

DETAIL NUMBER: SS-INDEX.01
-------------------------------



## SANITARY SEWER CONTINUED

<u>DESCRIPTION</u>	<u>DETAIL NUMBER</u>
TYPICAL OUTSIDE DROP MANHOLE DETAIL	SS.15
INSIDE DROP INLETS FOR PVC PIPE SEWERS (12-INCH DIAMETER AND SMALLER)	SS.16
PIPE TRENCH DAM DETAIL	SS.17
WYE-SADDLE DETAIL FOR SERVICE CONNECTION ON R.C. OR V.C. MAIN	SS.18
P.V.C. WYE INSERTED ON EXISTING MAIN	SS.19
TYPICAL UTILITY CROSSINGS	SS.20
SANITARY SEWER PROTECTION DURING SEWER EXTENSION CONSTRUCTION	SS.21
FORCE MAIN CLEANOUT MANHOLE DETAIL	SS.22
LOW PRESSURE SEWER SERVICE VALVE BOX	SS.23
THRUST BLOCKS	SS.24
COMBINATION AIR RELEASE VALVE	SS.25
HIGH VELOCITY MANHOLE INVERT	SS.26
STANDARD GREASE TRAP	SS.27
TYPICAL SEWER PLAN	SS.28
TYPICAL SEWER PROFILE	SS.29



### DEDHAM DPW DESIGN & CONSTRUCTION STANDARDS

DETAIL INDEX  
SANITARY SEWER

SCALE: NTS	DATE OF ISSUE: AUGUST 2015
---------------	-------------------------------

REVISED:

DETAIL NUMBER: SS-INDEX.02
-------------------------------

## GENERAL NOTES FOR PIPE TRENCHES

1. PIPE TRENCHES MAY BE EXCAVATED WIDER THAN TRENCH WIDTH  $W_s$  (SHEETED) OR  $W_u$  (UNSHEETED) ABOVE THE TOP OF PIPE ZONE.
2. TRENCHES SHALL NOT BE EXCAVATED BEYOND THE TRENCH WIDTH  $W_u$  BELOW THE TOP OF PIPE ZONE.
3. SHEETING MUST BE USED IF EXCAVATION AND BACKFILL, BELOW NORMAL DEPTH, IS REQUIRED. SHEETING SHALL BE LEFT IN PLACE AS SPECIFIED.
4. ALL ROCK WITHIN 3'-0" HORIZONTALLY OF THE ENDS OF BUILDING CONNECTIONS, BRANCHES OR STUBS AND DOWN TO A HORIZONTAL PLANE 6" BELOW THE BOTTOMS OF SUCH CONNECTIONS, BRANCHES OR STUBS, SHALL BE EXCAVATED.
5. WHERE INDICATED ON THE DRAWINGS, GEOTEXTILE FILTER FABRIC SHALL BE PROVIDED FOR SEWER AND BUILDING CONNECTION FOUNDATIONS. OVERLAP FABRIC ABOVE THE PIPE CROWN AND PROVIDE A MINIMUM OF 12" FABRIC OVERLAP.

TRENCH WIDTH $W_s$ OR $W_u$		
NOMINAL PIPE DIAMETER $D$	DEPTH OF PIPE INVERT BELOW GROUND SURFACE	
	0 TO 12'	12' TO 20'
24" AND SMALLER	5'-0"	7'-0"
OVER 24"	$D + 3'-0"$	$D + 5'-0"$



### DEDHAM DPW DESIGN & CONSTRUCTION STANDARDS

#### GENERAL NOTES FOR PIPE TRENCHES

SCALE: NTS	DATE OF ISSUE: AUGUST 2015
---------------	-------------------------------

REVISED:

DETAIL NUMBER: SS.01
-------------------------

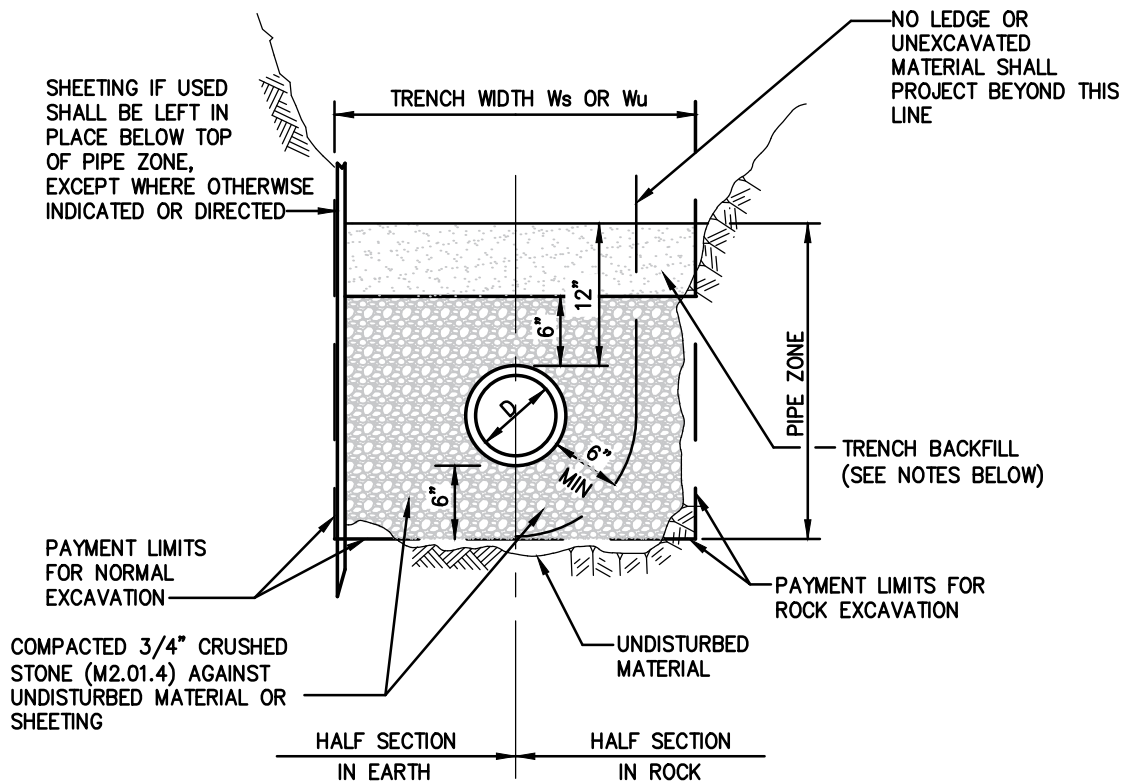

**NOTES:**

1. TRENCH BACKFILL TO BE USED WITHIN THE RIGHT-OF-WAY SHALL CONSIST OF EITHER GRAVEL BORROW MEETING MassDOT SPECIFICATION M1.03.0, TYPE "B" OR PROCESSED GRAVEL BORROW FOR SUBBASE MEETING MassDOT SPECIFICATION M1.03.1.
2. WHERE THE REMOVAL OF 100 SQUARE FEET OR LESS OF ASPHALT IS REQUIRED WITHIN THE RIGHT-OF-WAY, THEN THE TRENCH BACKFILL MATERIAL SHALL CONSIST OF CONTROLLED DENSITY FILL MEETING MassDOT SPECIFICATION M4.08.0, TYPE "1E" OR "2E".
3. TRENCH BACKFILL MATERIAL TO BE USED OUTSIDE OF THE RIGHT-OF-WAY MAY CONSIST OF MATERIAL GENERATED DURING EXCAVATIONS PROVIDED ALL STONES GREATER THAN 4" ARE REMOVED PRIOR TO PLACEMENT AND COMPACTION.
4. GRANULAR TRENCH BACKFILL MATERIAL USED WITHIN THE RIGHT-OF-WAY SHALL BE PLACED IN MAXIMUM 6" LIFTS AND MECHANICALLY COMPACTIONED TO A MINIMUM OF 95% OF THE MATERIAL'S MAXIMUM DRY DENSITY AND TO 90% ELSEWHERE AS DETERMINED BY ASTM D 1557.
5. REFER TO DETAILS RS.33-RS.35 FOR ASPHALT REPAIR REQUIREMENTS.



**DEDHAM DPW  
DESIGN & CONSTRUCTION STANDARDS**

TRENCH SECTION FOR SEWER PIPE  
18-INCH DIAMETER AND SMALLER

SCALE: NTS	DATE OF ISSUE: AUGUST 2015
REVISED:	
DETAIL NUMBER: SS.02	

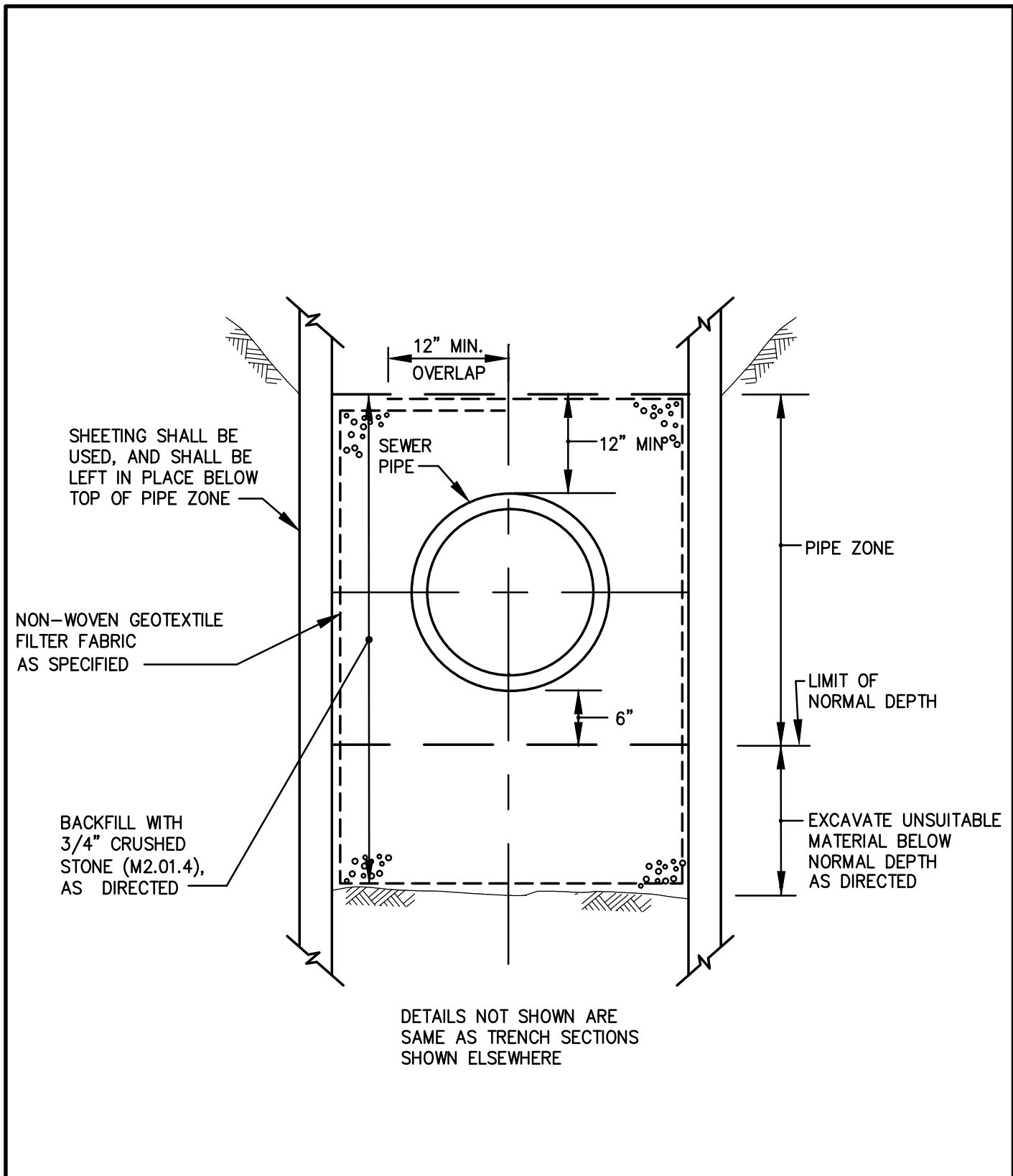

**DEDHAM DPW  
DESIGN & CONSTRUCTION STANDARDS**

**TRENCH SECTION IN UNSUITABLE MATERIAL**

SCALE: NTS	DATE OF ISSUE: AUGUST 2015
REVISED:	
DETAIL NUMBER: SS.03	

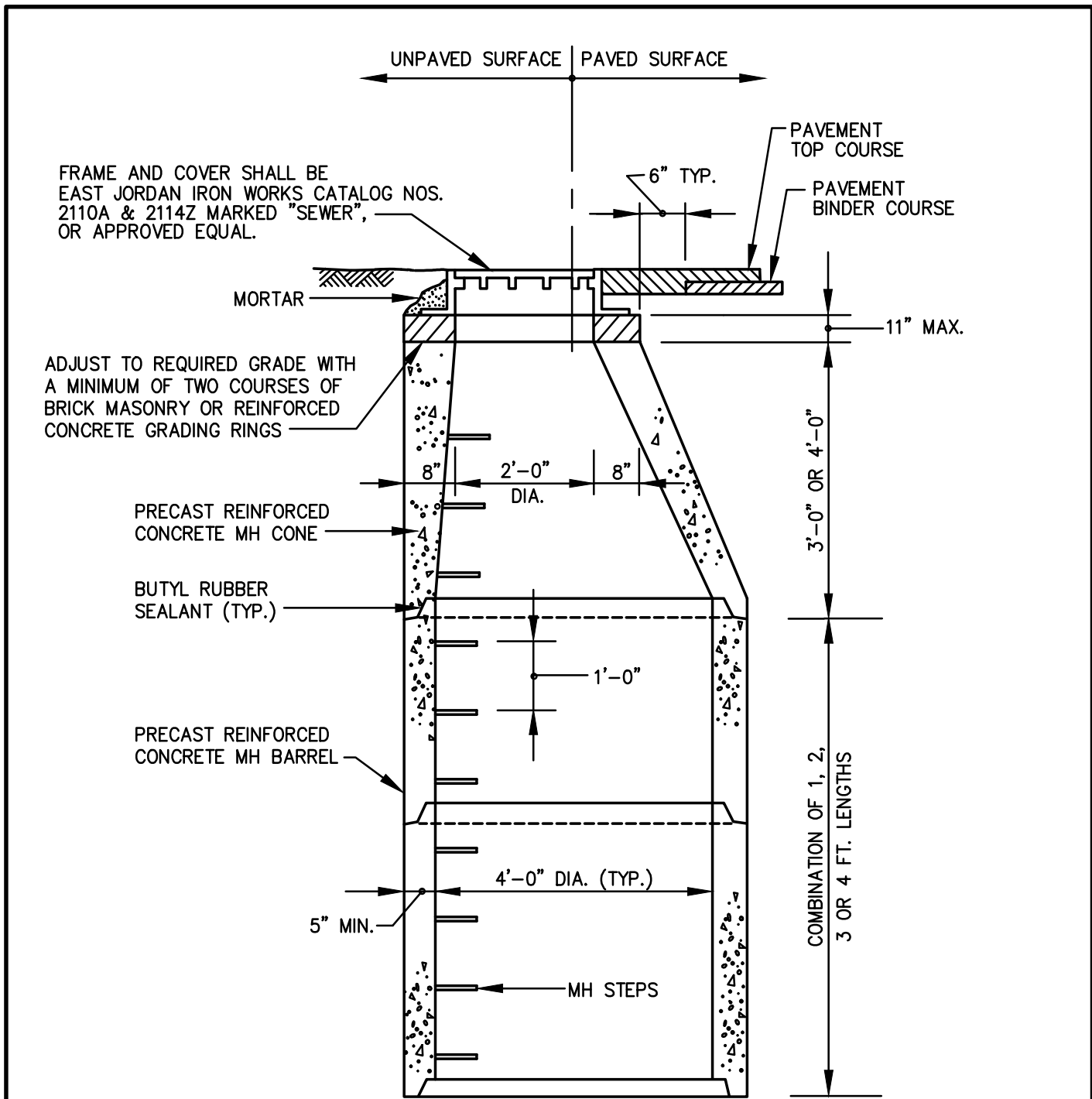

NOTE:  
 ALL EXTERIOR SURFACES OF MANHOLE GRADE ADJUSTMENT COURSES SHALL BE COVERED WITH 1/4" TO 3/8" MASONRY CEMENT PLASTER.



**DEDHAM DPW  
 DESIGN & CONSTRUCTION STANDARDS**

MANHOLE RISER WITH ECCENTRIC CONE TOP

SCALE: NTS	DATE OF ISSUE: AUGUST 2015
REVISED:	
DETAIL NUMBER: SS.04	

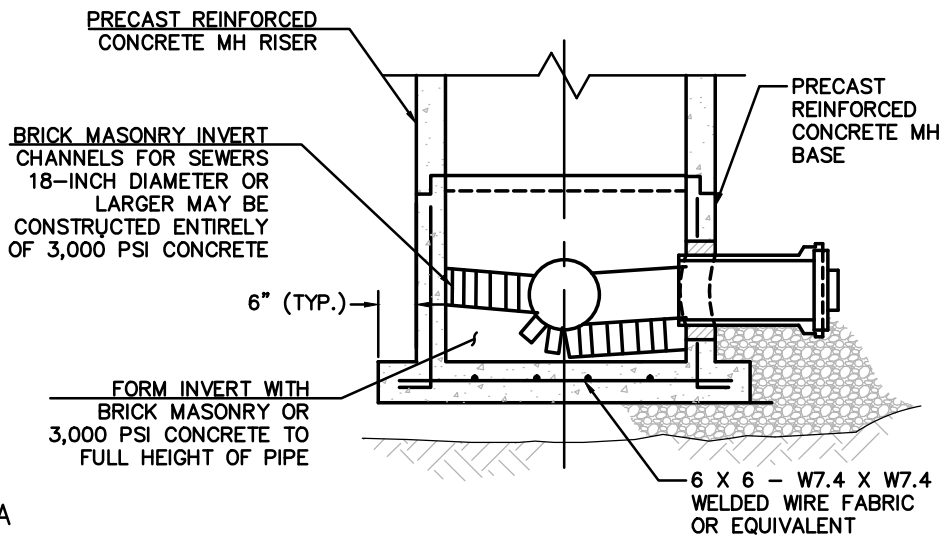

**SECTION A-A**

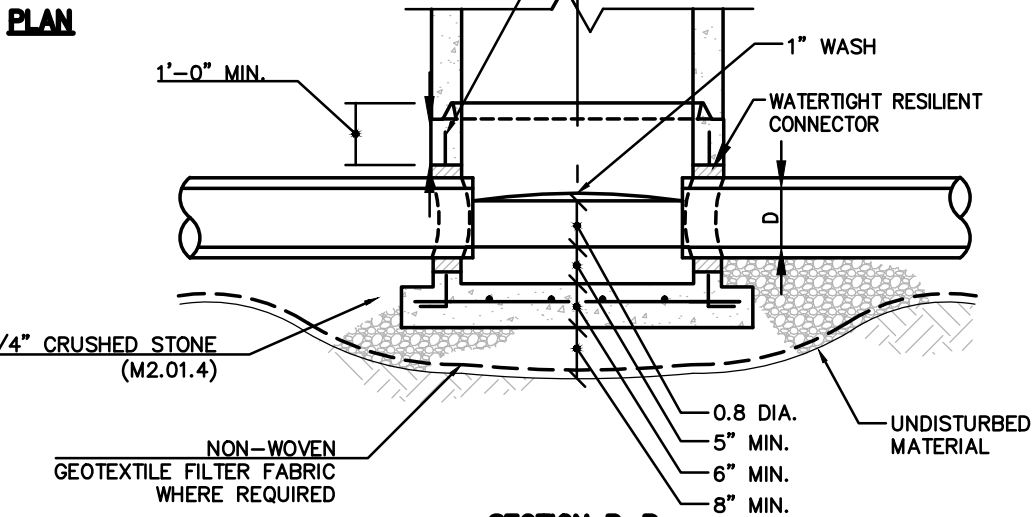
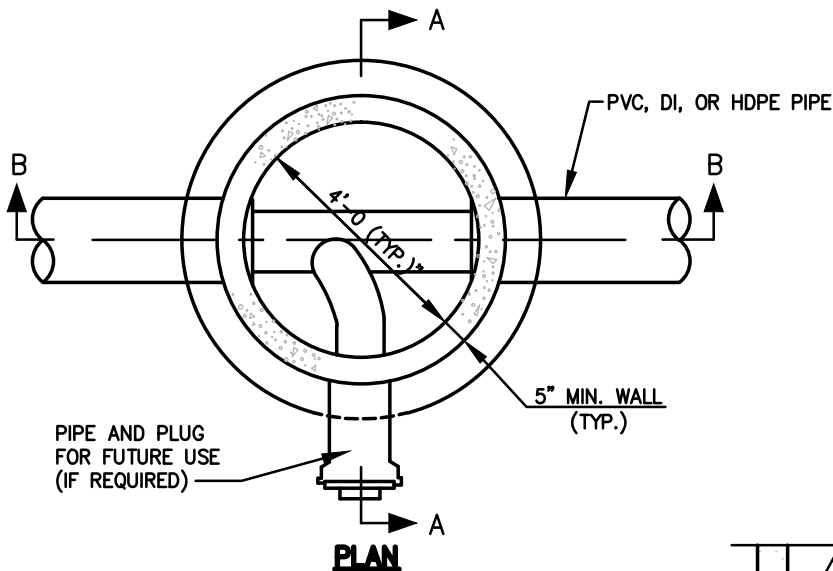

**SECTION B-B**



**DEDHAM DPW  
DESIGN & CONSTRUCTION STANDARDS**

PRECAST REINFORCED CONCRETE  
MANHOLE BASE FOR SEWERS

SCALE: DATE OF ISSUE:  
NTS AUGUST 2015

REVISED:

DETAIL NUMBER:  
SS.05

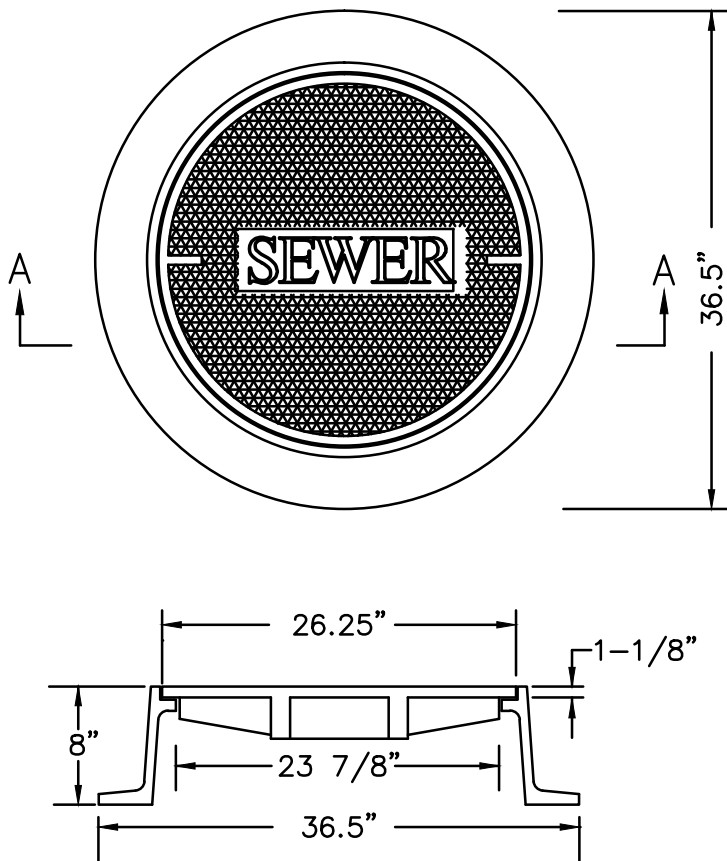

**SECTION A-A**

NOTE:

FRAME AND COVER SHALL BE EAST JORDAN IRON WORKS CATALOG NOS. 2110A & 2114Z MARKED "SEWER", OR APPROVED EQUAL.



**DEDHAM DPW  
DESIGN & CONSTRUCTION STANDARDS**

MANHOLE FRAME & COVER  
MARKED "SEWER"

SCALE: NTS	DATE OF ISSUE: AUGUST 2015
---------------	-------------------------------

REVISED:

DETAIL NUMBER: SS.06
-------------------------

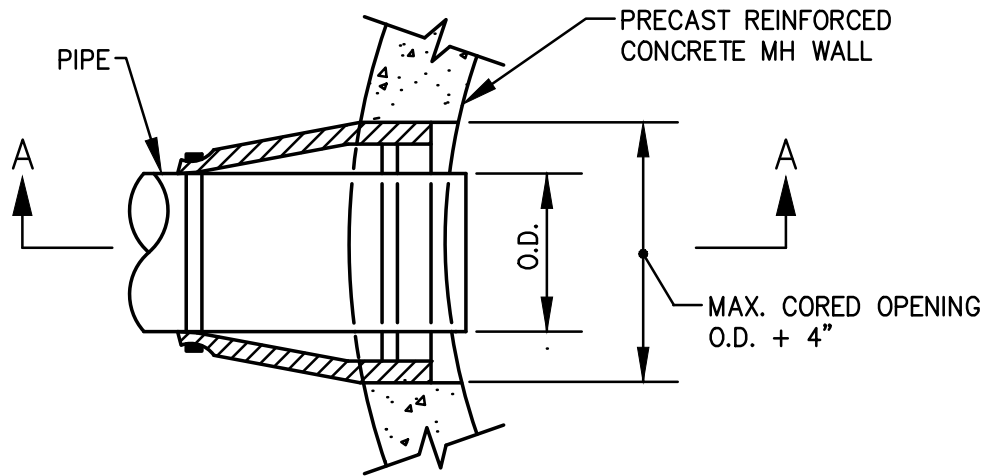

**PLAN**

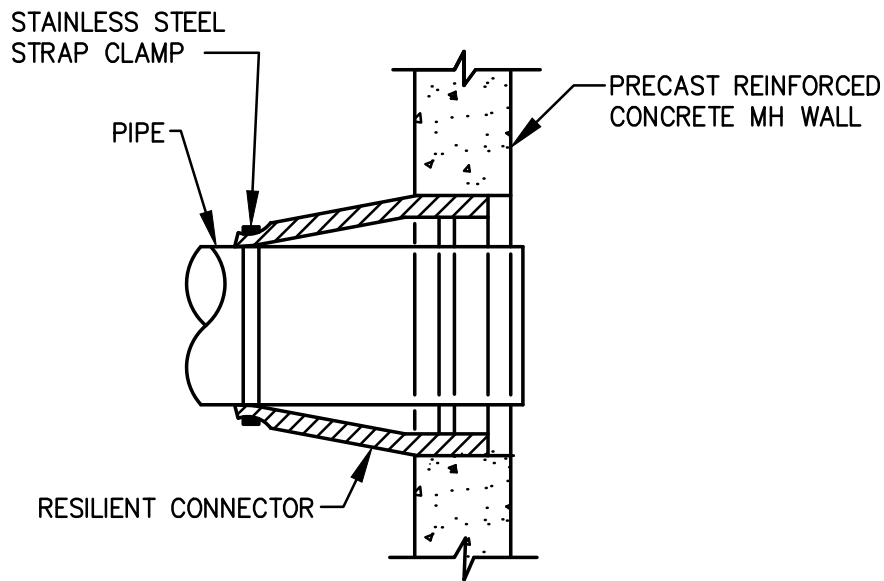

**SECTION A-A**



**DEDHAM DPW  
DESIGN & CONSTRUCTION STANDARDS**

**WATERTIGHT RESILIENT CONNECTOR FOR CONNECTING  
PIPES TO PRECAST CONCRETE MANHOLES**

SCALE: NTS	DATE OF ISSUE: AUGUST 2015
---------------	-------------------------------

REVISED:

DETAIL NUMBER: SS.07
-------------------------



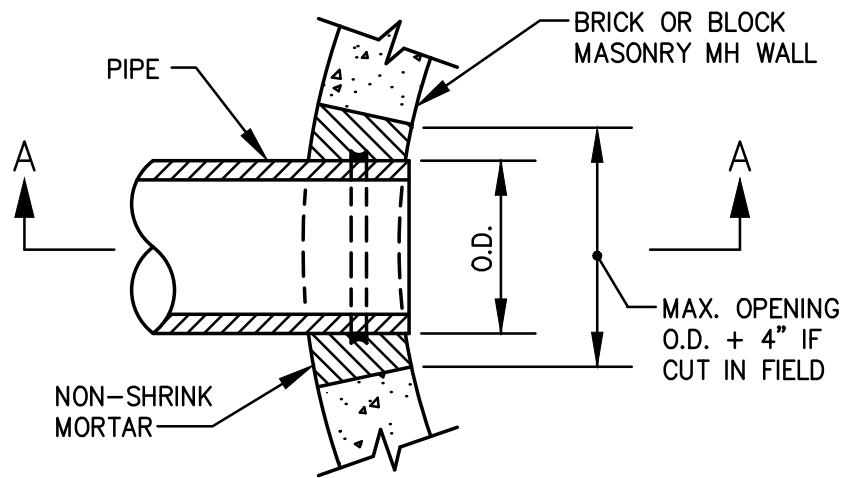

**PLAN**

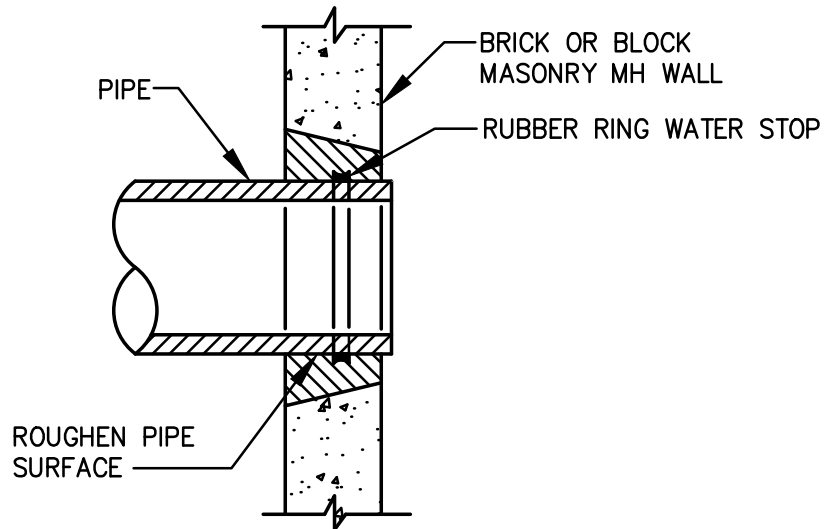

**SECTION A-A**

**NOTES:**

1. THIS METHOD ONLY TO BE USED UNDER SPECIAL CIRCUMSTANCES AND WITH PRIOR APPROVAL FROM THE DIRECTOR OF ENGINEERING. THE WATERTIGHT RESILIENT CONNECTOR IS THE PREFERRED CONNECTION METHOD.



**DEDHAM DPW  
DESIGN & CONSTRUCTION STANDARDS**

NON-SHRINK MORTAR JOINTS FOR CONNECTING  
PIPES TO BRICK OR BLOCK MASONRY MANHOLES

SCALE: NTS	DATE OF ISSUE: AUGUST 2015
---------------	-------------------------------

REVISED:

DETAIL NUMBER: SS.08
-------------------------

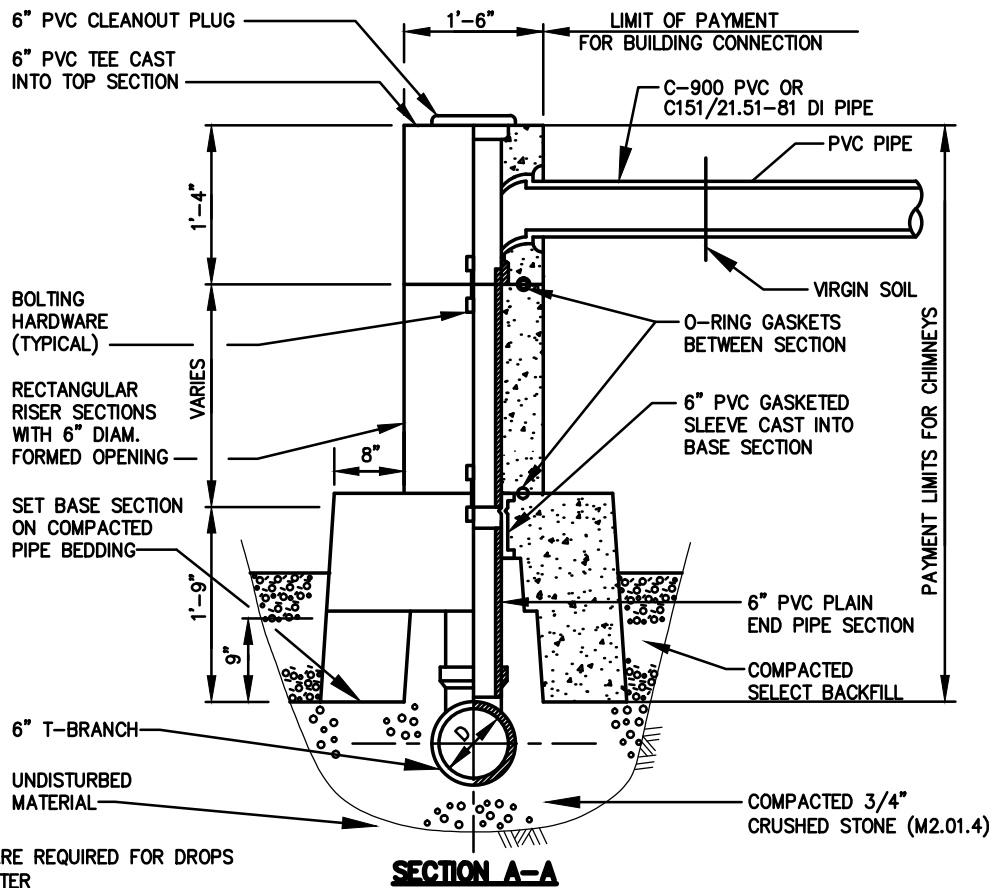
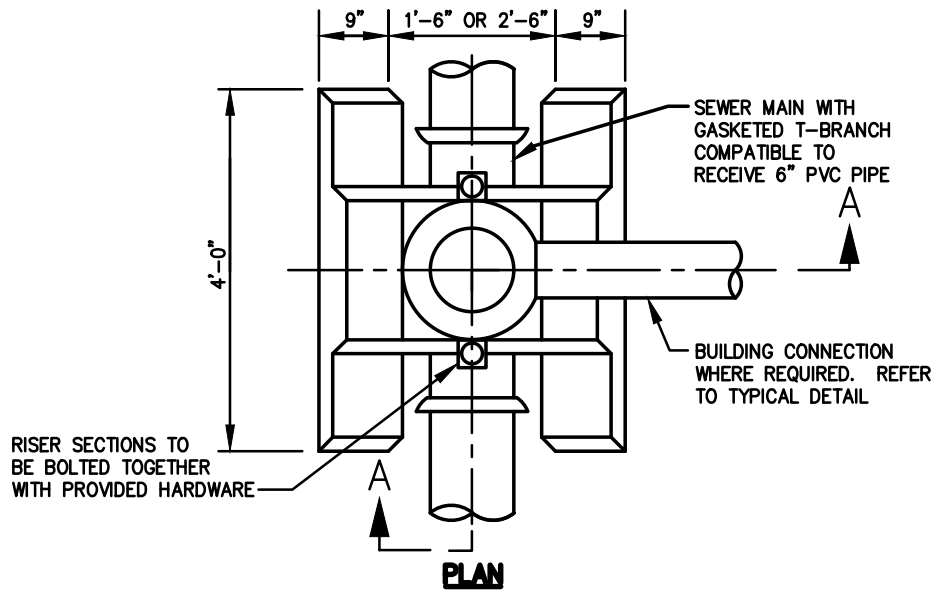

\* CHIMNEYS ARE REQUIRED FOR DROPS 3' OR GREATER



## DEDHAM DPW DESIGN & CONSTRUCTION STANDARDS

PRECAST REINFORCED CONCRETE SEWER CHIMNEY

SCALE: NTS	DATE OF ISSUE: AUGUST 2015
---------------	-------------------------------

REVISED:

DETAIL NUMBER: SS.09
-------------------------

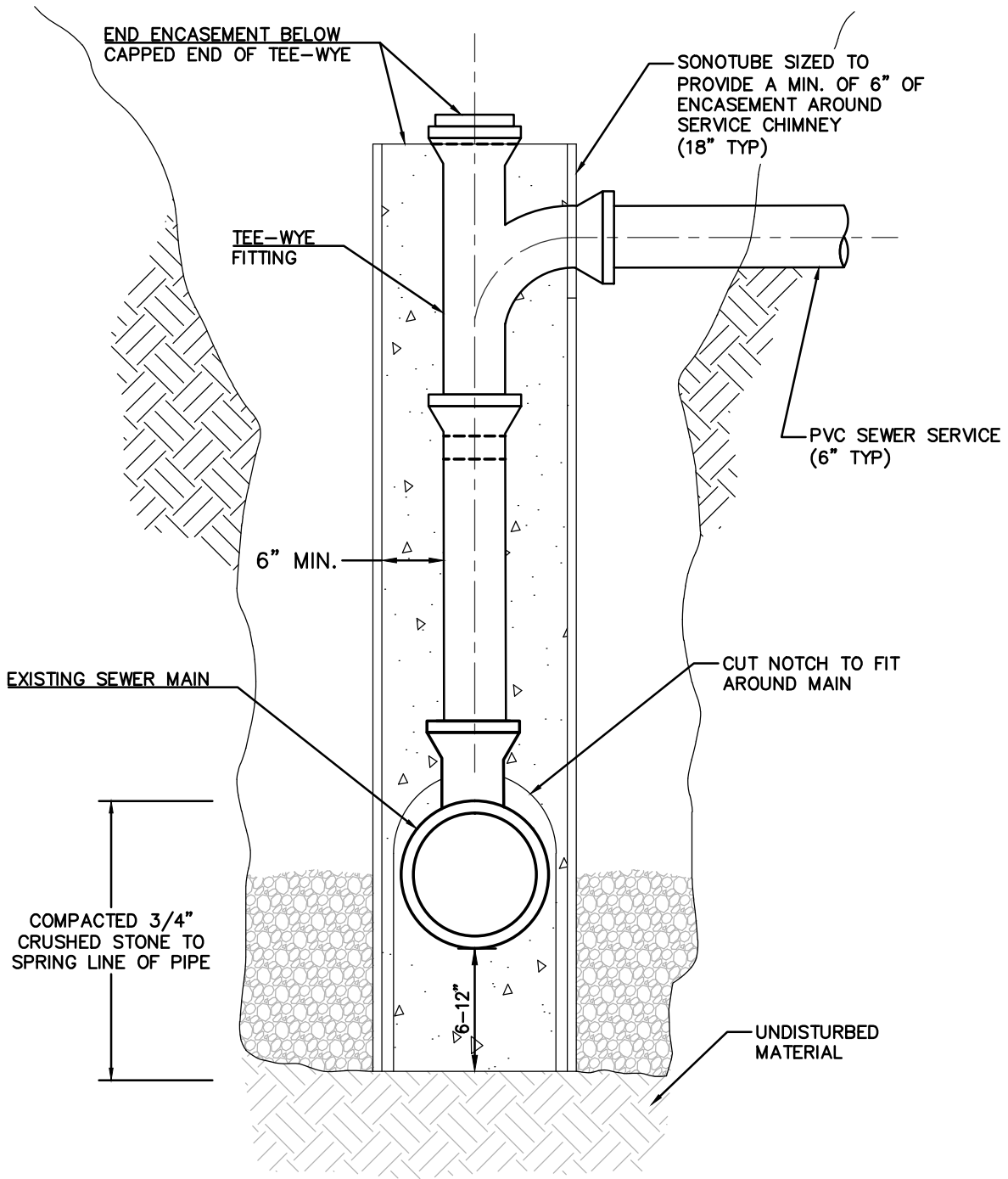

\* CHIMNEYS ARE REQUIRED FOR DROPS 3' OR GREATER



**DEDHAM DPW  
DESIGN & CONSTRUCTION STANDARDS**

TYPICAL SONOTUBE  
CAST-IN-PLACE SEWER CHIMNEY

SCALE: NTS	DATE OF ISSUE: AUGUST 2015
---------------	-------------------------------

REVISED:

DETAIL NUMBER: SS.10
-------------------------

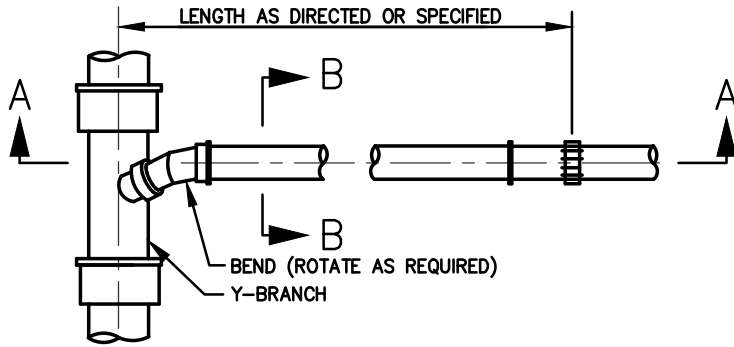

**PLAN**

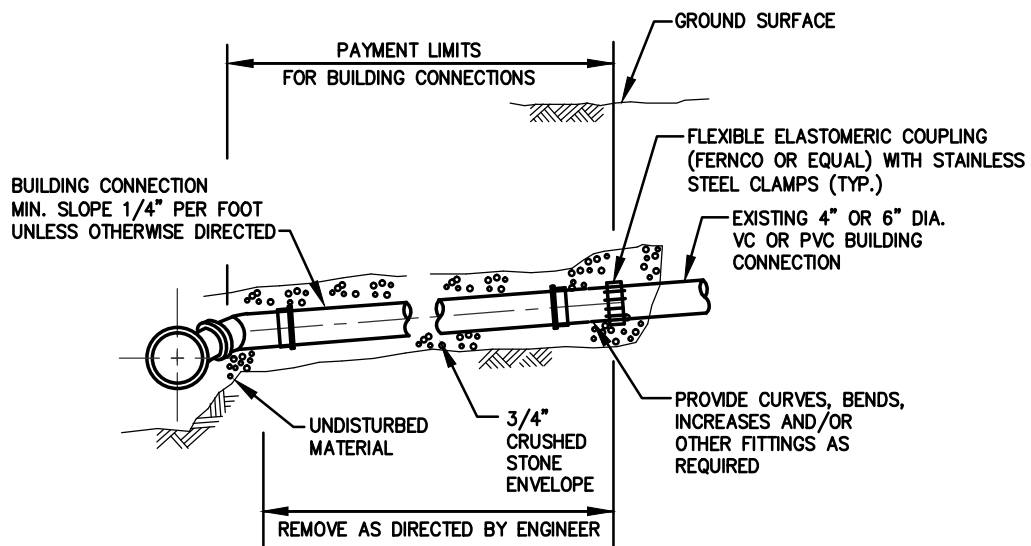

**SECTION A-A**

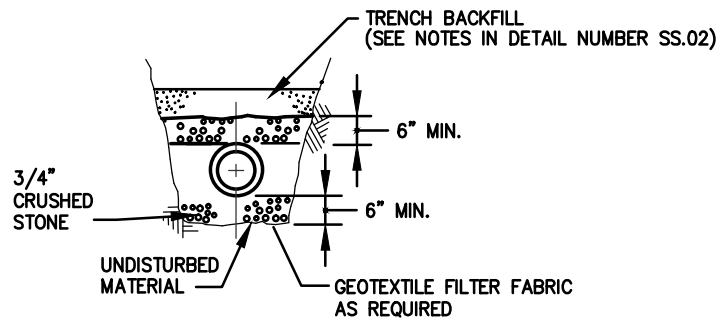

**SECTION B-B**



**DEDHAM DPW  
DESIGN & CONSTRUCTION STANDARDS**

**RECONSTRUCTED BUILDING CONNECTION**

SCALE: NTS      DATE OF ISSUE:  
AUGUST 2015

REVISED:

DETAIL NUMBER:  
SS.11

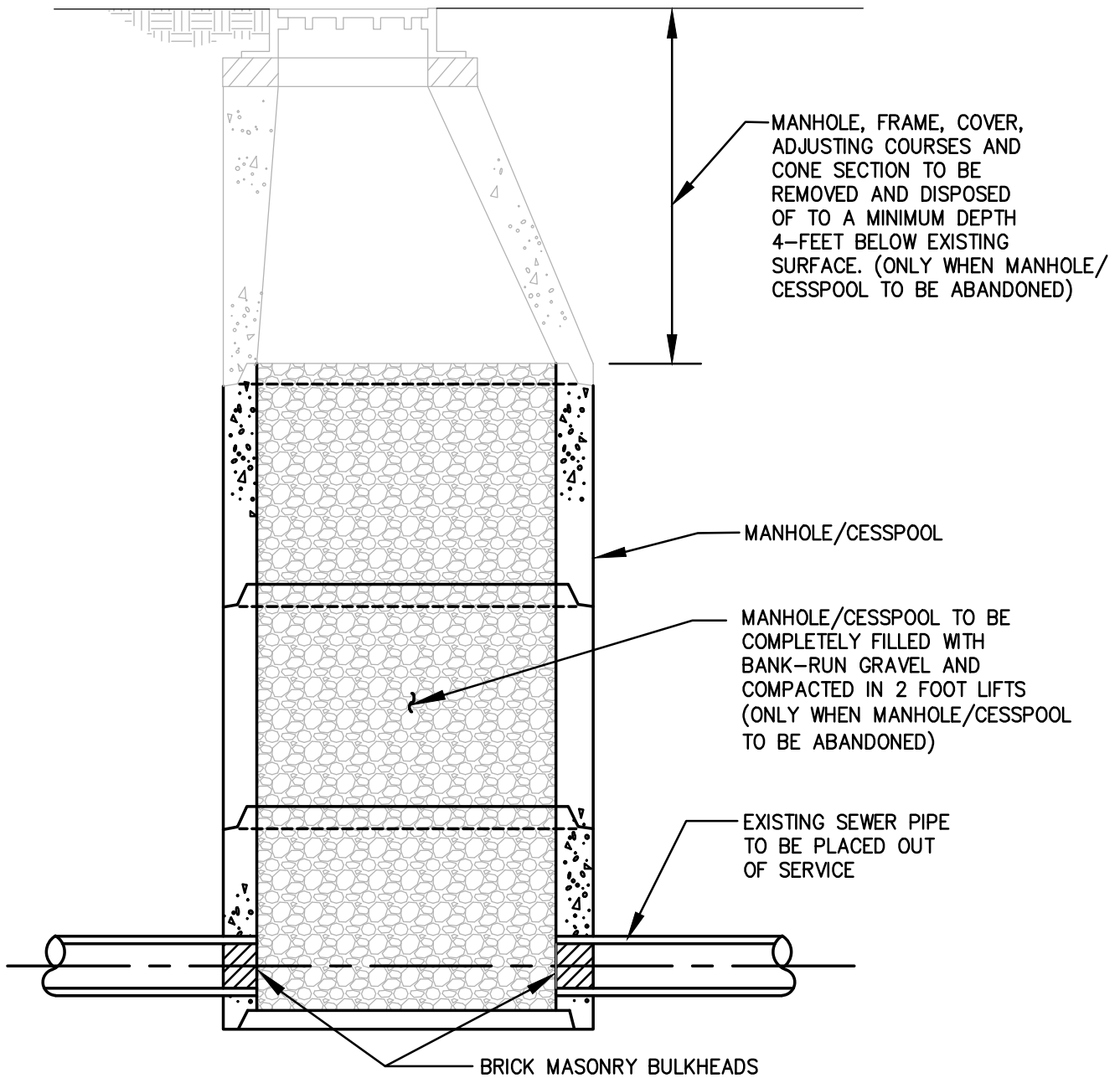

**DEDHAM DPW  
DESIGN & CONSTRUCTION STANDARDS**

**ABANDON EXISTING MANHOLES/CESSPOOLS**

SCALE: NTS	DATE OF ISSUE: AUGUST 2015
REVISED:	
DETAIL NUMBER: SS.12	

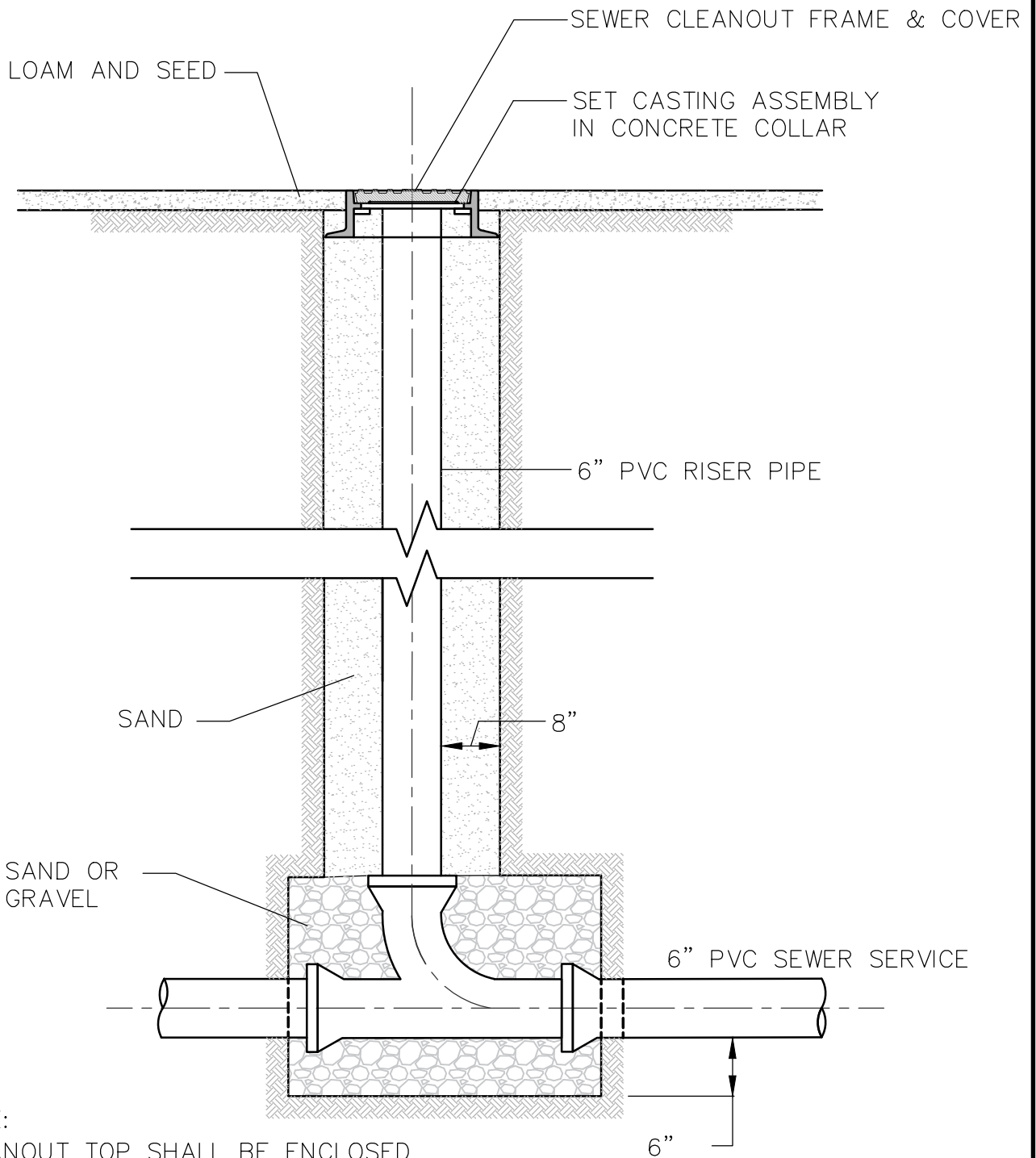

NOTE:  
 CLEANOUT TOP SHALL BE ENCLOSED  
 IN CASTING AND/OR FABRICATED  
 COVER ASSEMBLY.



**DEDHAM DPW  
 DESIGN & CONSTRUCTION STANDARDS**

TYPICAL SEWER CLEANOUT DETAIL

SCALE: NTS	DATE OF ISSUE: AUGUST 2015
REVISED:	
DETAIL NUMBER: SS.13	

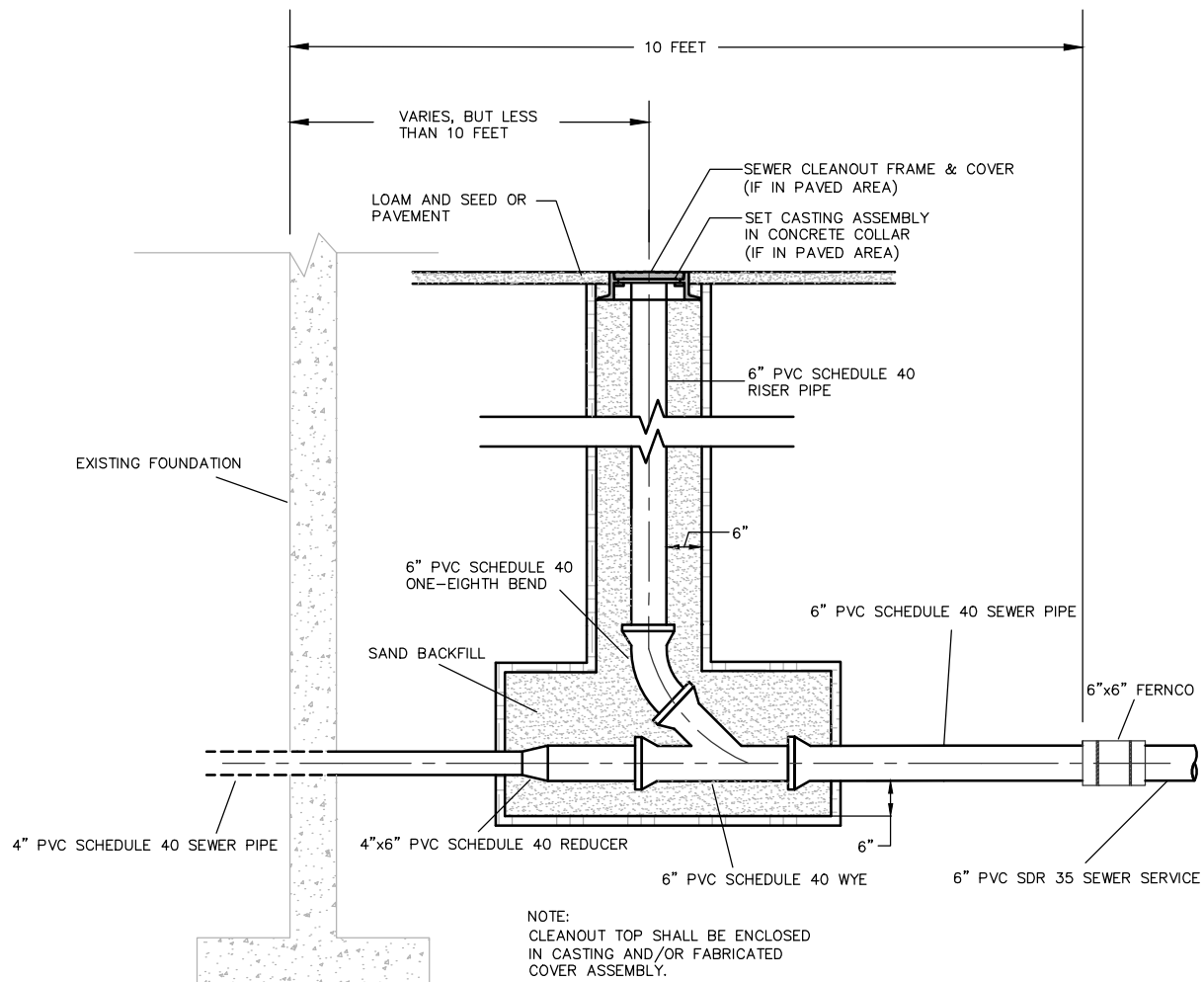

NOTES:

1. SEWER CLEANOUTS SHALL TYPICALLY BE LOCATED A MINIMUM OF 10' FROM THE FOUNDATION. HOWEVER, IN SPECIAL CIRCUMSTANCES THE CLEANOUT MAY BE LOCATED WITHIN 10' OF THE FOUNDATION WITH PERMISSION FROM THE ENGINEERING DEPARTMENT. THE 10' ZONE SHALL BE CONSIDERED THE DISTANCE FROM THE INSIDE FACE OF THE FOUNDATION TO A DISTANCE OF 10' OUTSIDE OF THE FOUNDATION, PERPENDICULAR TO THE INSIDE FACE OF THE FOUNDATION.
2. ALL WORK TO BE CONDUCTED WITHIN THE 10' ZONE SHALL BE PERFORMED BY A PLUMBER LICENSED IN THE STATE OF MASSACHUSETTS AND SHALL CONFORM TO 248 CMR 2.00 AND 248 CMR 10.00.



**DEDHAM DPW  
DESIGN & CONSTRUCTION STANDARDS**

**SEWER CLEANOUT DETAIL WITHIN  
10' OF BUILDING FOUNDATION**

SCALE: NTS	DATE OF ISSUE: AUGUST 2015
REVISED:	
DETAIL NUMBER: SS.14	

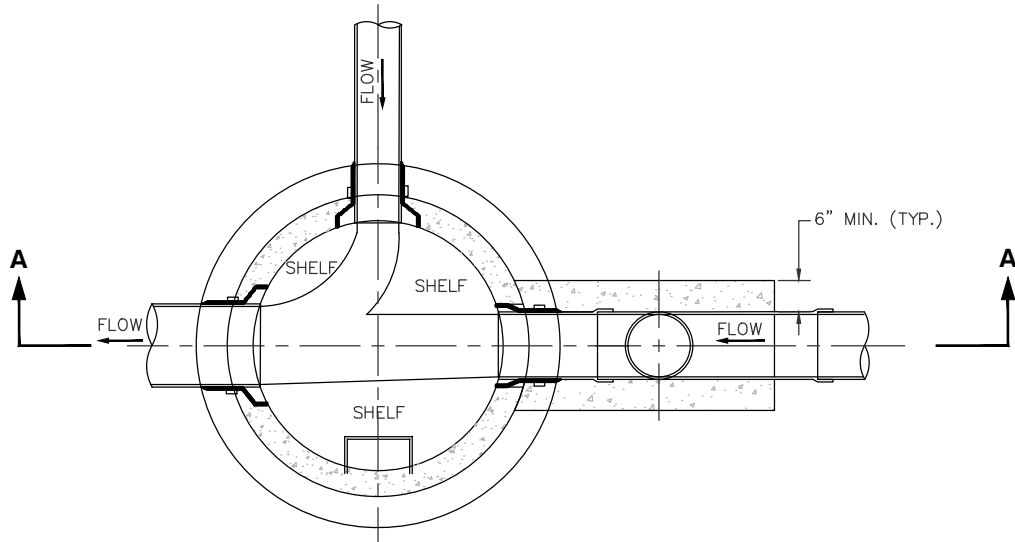

**PLAN**

PROVIDE WATERTIGHT RESILIENT CONNECTOR

INSTALL A 1/2" PVC PUSH CAP OR BUILD MASONRY DAM AS DIRECTED BY ENGINEER

CONCRETE ENCASUREMENT TO EXTEND TO SPRINGLINE OF PIPE

PROVIDE WATERTIGHT RESILIENT CONNECTOR

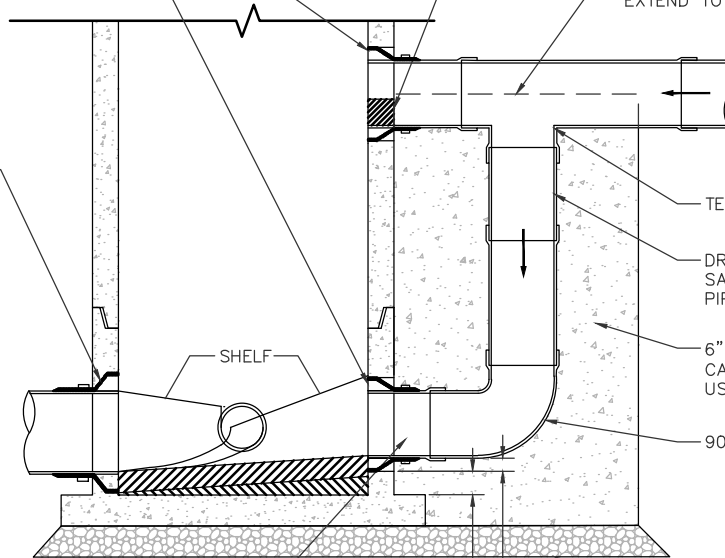

**SECTION A-A**

PIPE LENGTH AS SHORT AS POSSIBLE

DROP CONNECTION SHALL BE SAME SIZE AS THE HORIZONTAL PIPE.

6" MIN. TYPICAL CAST-IN-PLACE CONCRETE. USE FORMS

90° BEND

12" OF 3/4" CRUSHED STONE BEDDING

**NOTES:**

1. DROP MANHOLES ARE REQUIRED WHEN THE VERTICAL DROP IS 24" OR GREATER.
2. DROP PIPE AND FITTINGS SHALL BE THE SAME DIAMETER AS THE INCOMING SEWER PIPE.



**DEDHAM DPW  
DESIGN & CONSTRUCTION STANDARDS**

**TYPICAL OUTSIDE DROP MANHOLE DETAIL**

SCALE: NTS      DATE OF ISSUE: AUGUST 2015

REVISED:

DETAIL NUMBER: SS.15



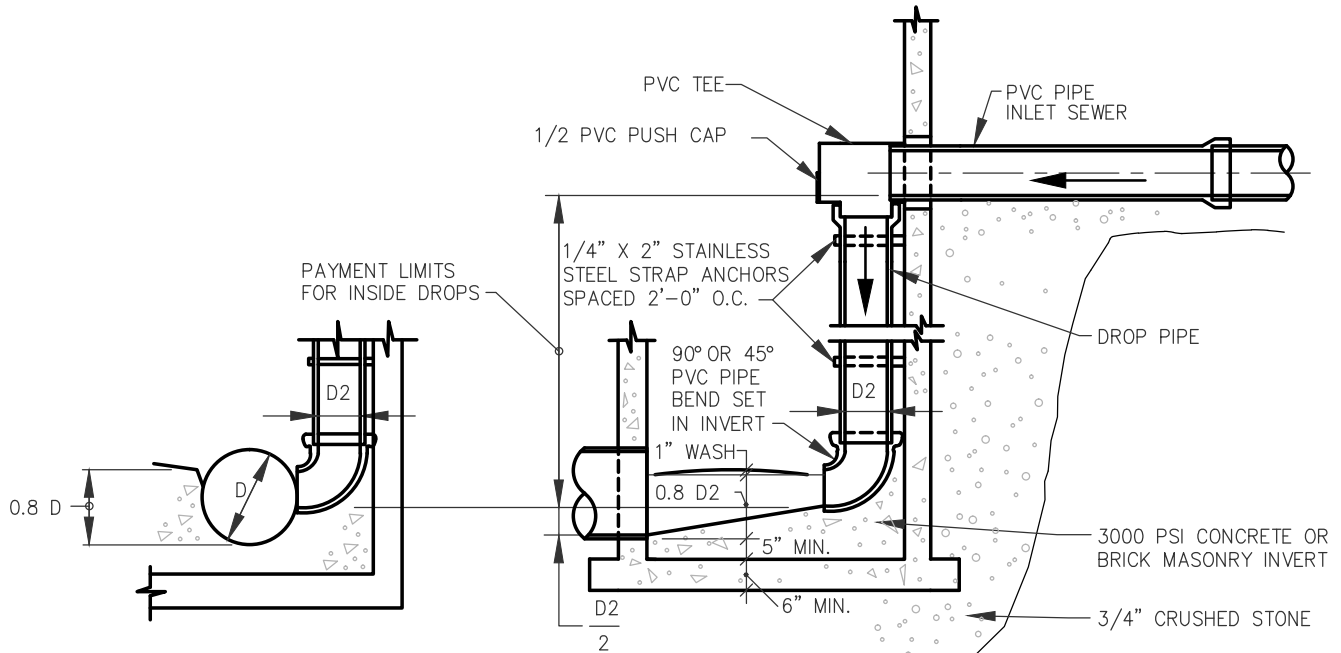

INVERT DETAIL  
AT SIDE DROPS

INVERT DETAIL  
AT MAIN RUN DROPS

**NOTES:**

1. INSIDE DROPS ARE ONLY ALLOWED WHEN OUTSIDE DROPS ARE IMPRACTICAL AND ONLY WITH THE PRIOR APPROVAL OF THE DIRECTOR OF ENGINEERING.
2. DROP MANHOLES ARE REQUIRED WHEN THE VERTICAL DROP IS 24" OR GREATER.
3. DROP PIPE AND FITTINGS SHALL BE THE SAME DIAMETER AS THE INCOMING SEWER PIPE.
4. MANHOLE SHALL HAVE SUFFICIENT DIAMETER FOR ENTRY WITH DROP PIPE INSTALLED (5' TYPICAL).



**DEDHAM DPW  
DESIGN & CONSTRUCTION STANDARDS**

INSIDE DROPS FOR PVC SEWERS  
12-INCH DIAMETER AND SMALLER

SCALE: NTS	DATE OF ISSUE: AUGUST 2015
---------------	-------------------------------

REVISED:

DETAIL NUMBER: SS.16
-------------------------

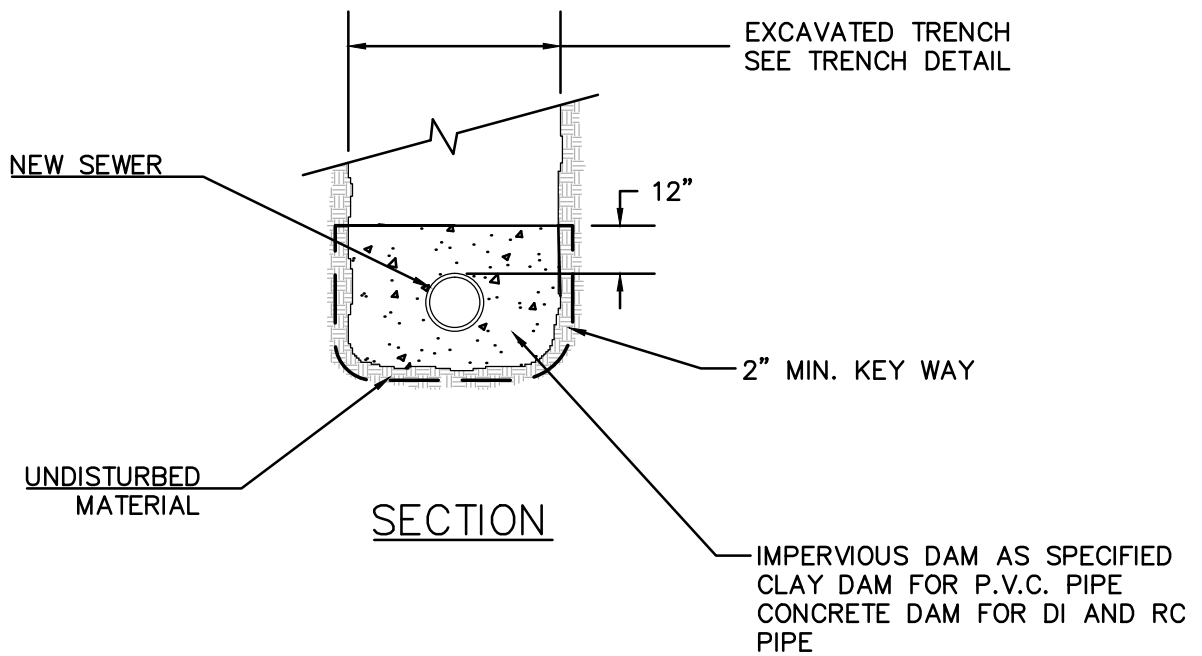
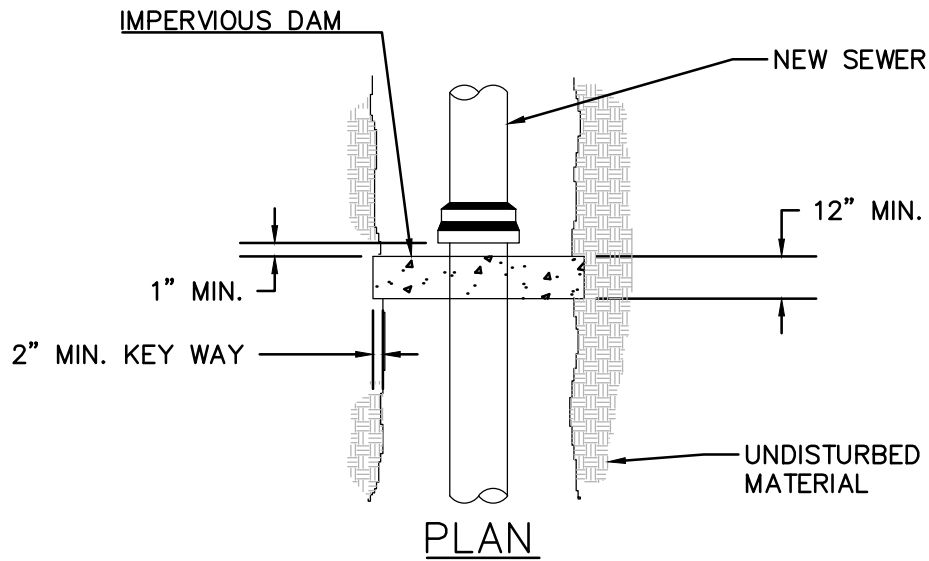

**DEDHAM DPW  
DESIGN & CONSTRUCTION STANDARDS**

PIPE TRENCH DAM DETAIL

SCALE: DATE OF ISSUE:  
NTS AUGUST 2015

REVISED:

DETAIL NUMBER:  
SS.17

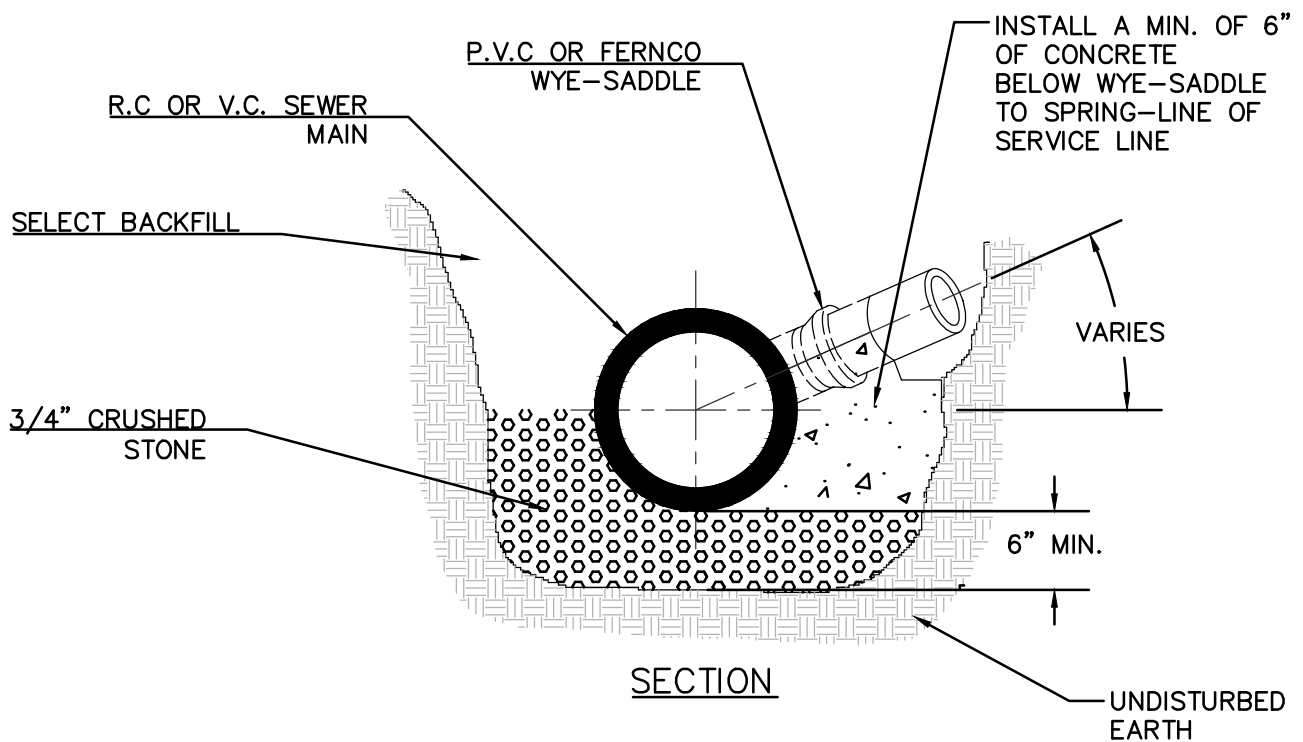
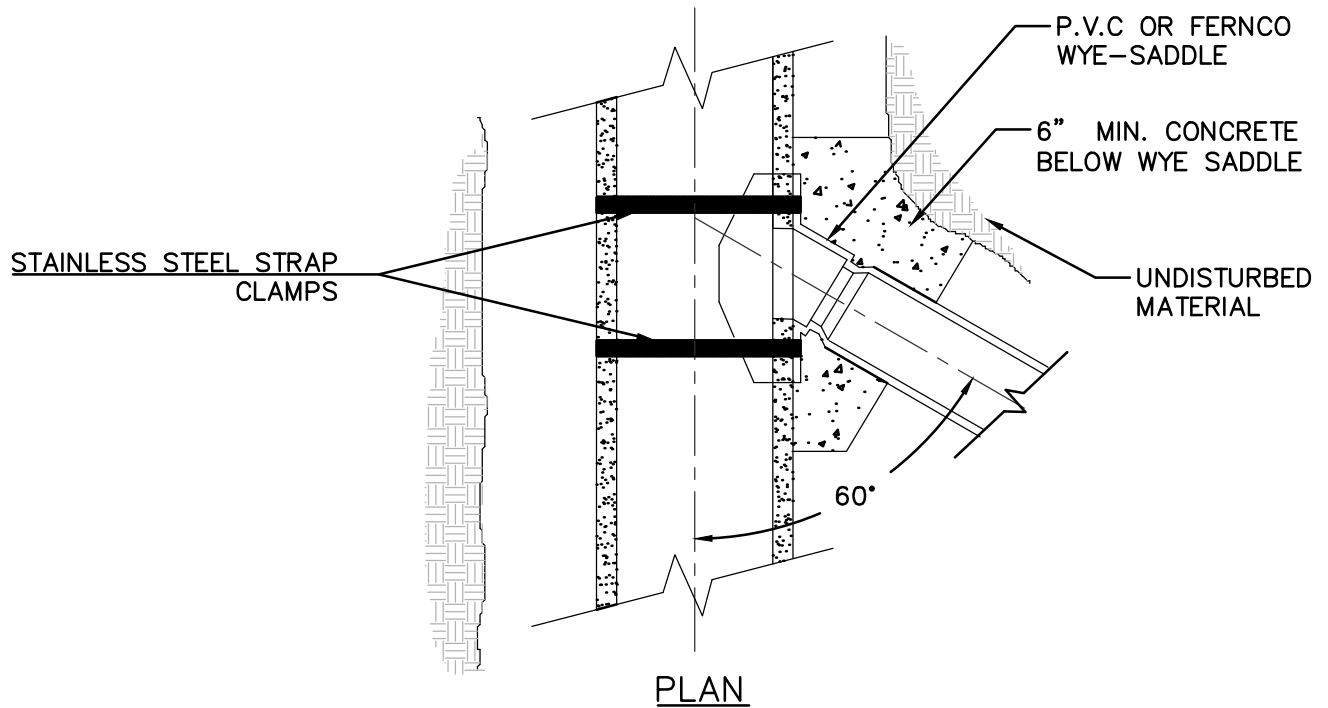

**DEDHAM DPW  
DESIGN & CONSTRUCTION STANDARDS**

**WYE-SADDLE DETAIL FOR SERVICE CONNECTION  
ON R.C. OR V.C. MAIN**

SCALE: NTS	DATE OF ISSUE: AUGUST 2015
---------------	-------------------------------

REVISED:

DETAIL NUMBER: SS.18
-------------------------

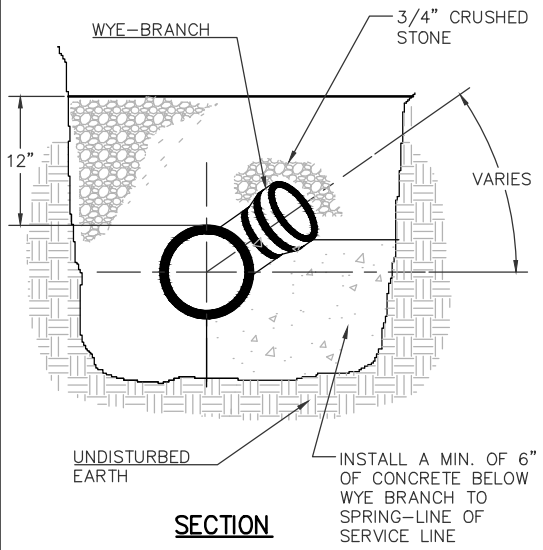

**SECTION**

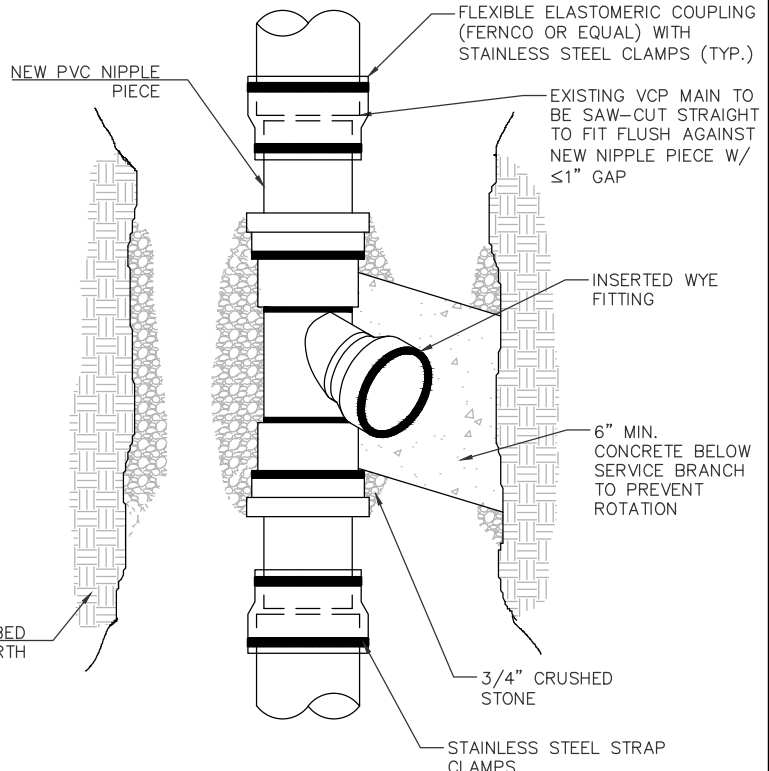

**PLAN - VCP MAIN**

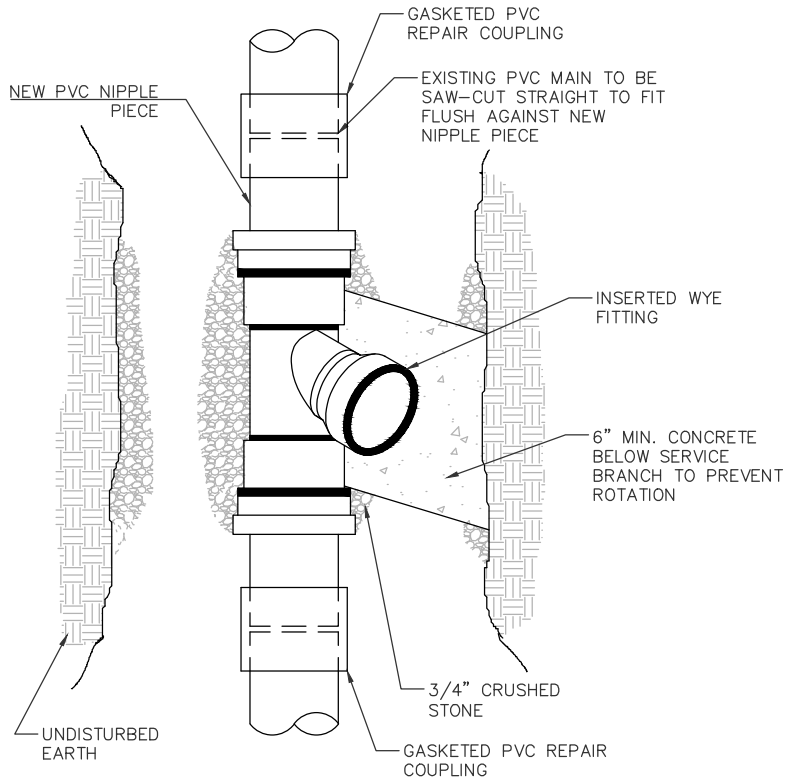

**PLAN - PVC MAIN**



**DEDHAM DPW  
DESIGN & CONSTRUCTION STANDARDS**

P.V.C. WYE INSERTED ON EXISTING MAIN

SCALE: NTS	DATE OF ISSUE: AUGUST 2015
REVISED:	
DETAIL NUMBER: SS.19	

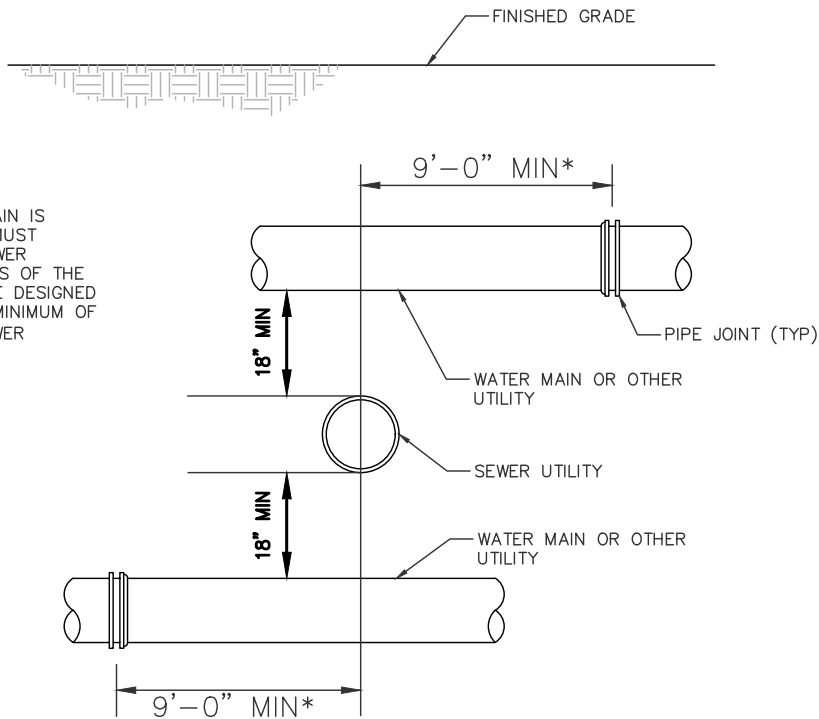

\* WHEN A NEW WATER MAIN IS BEING INSTALLED AND MUST CROSS AN EXISTING SEWER UTILITY, THE PIPE JOINTS OF THE WATER MAIN SHOULD BE DESIGNED SO THAT THEY ARE A MINIMUM OF 9' AWAY FROM THE SEWER UTILITY.

NOTES:

1. ANY WATER MAIN OR OTHER UTILITY SHALL NOT BE INSTALLED WITHIN 6" ABOVE OR BELOW AN EXISTING SEWER MAIN OR LATERAL. ALL EFFORTS SHALL BE MADE TO DESIGN UTILITIES WITH THE MINIMUM 18" OF SEPARATION FROM EXISTING SEWER MAINS OR LATERALS.
2. ALL BACKFILLING OPERATIONS FOR SEWER MAINS AND LATERALS SHALL FOLLOW DETAIL NO. SS.02 UNLESS OTHERWISE STATED BELOW.
3. WHERE A WATER MAIN / UTILITY IS TO BE INSTALLED BELOW AN EXISTING VC SEWER MAIN, REGARDLESS OF SEPARATION DISTANCE, THE SEWER MAIN SHALL BE ADEQUATELY SUPPORTED. IF IN THE OPINION OF THE ENGINEER THAT THE SEWER MAIN CANNOT BE ADEQUATELY SUPPORTED, IT SHALL BE EITHER LINED USING APPROVED CIPP METHODS PRIOR TO EXCAVATION BELOW THE SEWER MAIN OR SHALL BE REPLACED WITH PVC C900. IF PVC C900 IS USED, MECHANICAL JOINTS OR AN APPROVED EQUAL THAT ARE WATERTIGHT SHALL BE USED TO FASTEN THE C900 TO THE EXISTING VC SEWER MAIN.
4. WHENEVER A WATER MAIN IS TO BE INSTALLED WITHIN 18" ABOVE AN EXISTING VC SEWER MAIN, IF THE WATER MAIN IS GREATER THAN 12" IN DIAMETER, THE SEWER MAIN SHALL BE LINED USING APPROVED CIPP METHODS PRIOR TO THE INSTALLATION OF THE WATER UTILITY.
5. WHERE A WATER MAIN IS TO BE INSTALLED BELOW AN EXISTING VC SEWER LATERAL, REGARDLESS OF SEPARATION DISTANCE, THE SEWER LATERAL SHALL BE EITHER ENCASED IN A MINIMUM OF 6" OF CONCRETE FOR A MINIMUM OF 10' ON EACH SIDE OF THE CROSSING, OR THE SEWER LATERAL SHALL BE REMOVED AND REPLACED WITH PVC SDR 35 PIPE FOR THE FULL WIDTH OF THE TRENCH. FERNCO COUPLINGS, OR APPROVED EQUALS THAT ARE WATERTIGHT SHALL BE USED TO CONNECT THE PVC PIPE TO THE EXISTING VC SEWER LATERAL.
6. WHENEVER A WATER MAIN / UTILITY IS TO BE INSTALLED WITHIN 18" ABOVE AN EXISTING VC SEWER LATERAL, IF THE WATER MAIN / UTILITY IS GREATER THAN 12" DIAMETER, THE SEWER LATERAL SHALL BE EITHER REMOVED AND REPLACED WITH PVC C900 OR DI PIPE FOR THE FULL WIDTH OF THE TRENCH OR THE SEWER LATERAL SHALL BE LINED USING APPROVED CIPP METHODS FOR A MINIMUM DISTANCE OF 10' ON EACH SIDE OF THE CROSSING.
7. WHERE A WATER MAIN / UTILITY IS INSTALLED BELOW AN EXISTING SEWER LATERAL, IF THE LATERAL IS COMPRISED OF CI, DI OR PVC MATERIAL, THE LATERAL CAN REMAIN IN PLACE PROVIDED IT IS ADEQUATELY SUPPORTED DURING EARTHWORK ACTIVITIES.



**DEDHAM DPW  
DESIGN & CONSTRUCTION STANDARDS**

TYPICAL UTILITY CROSSINGS

SCALE: NTS	DATE OF ISSUE: AUGUST 2015
REVISED: 7/26/2018	
DETAIL NUMBER: SS.20	

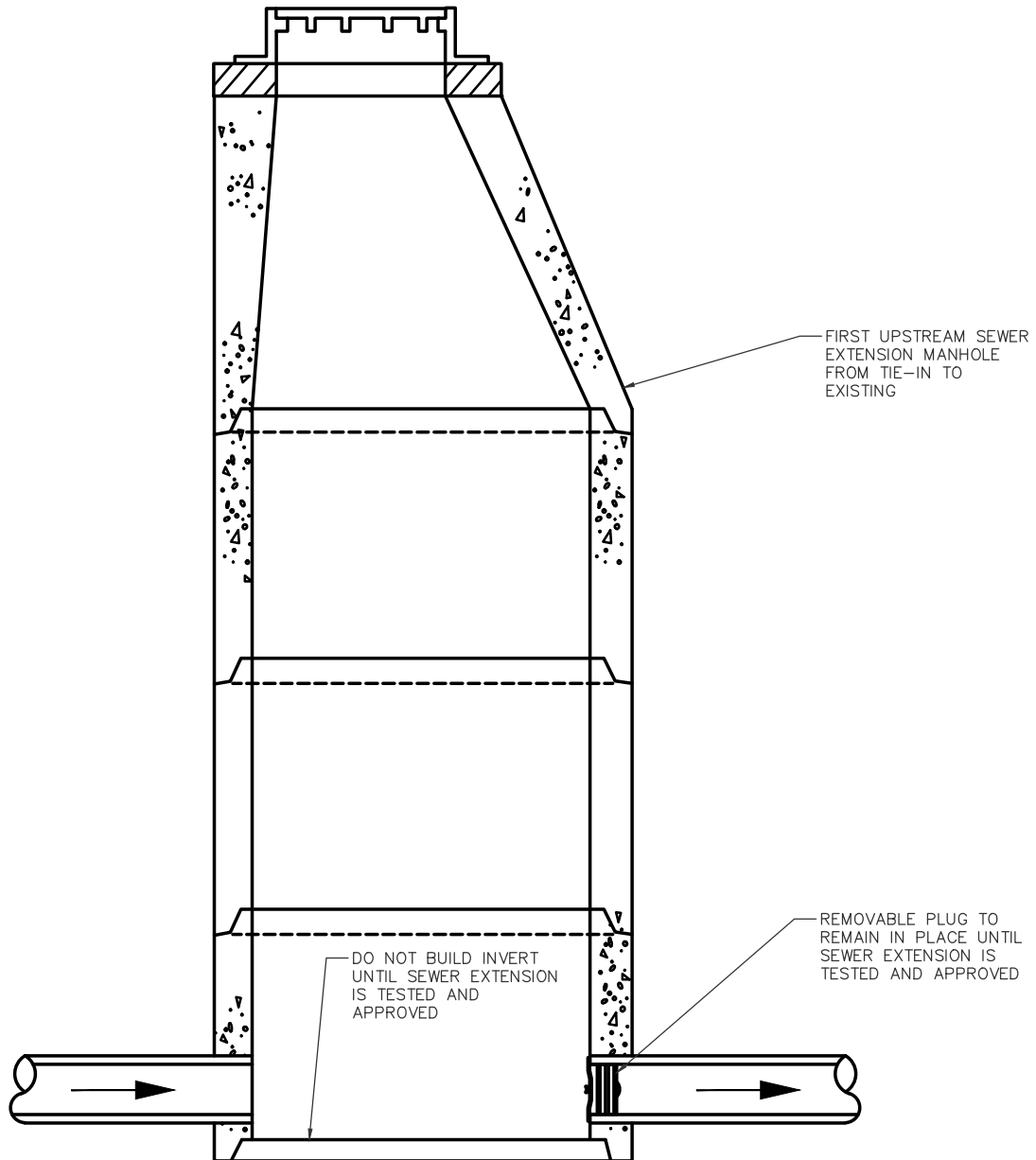

**DEDHAM DPW  
DESIGN & CONSTRUCTION STANDARDS**

SANITARY SEWER PROTECTION DURING  
SEWER EXTENSION CONSTRUCTION

SCALE: NTS	DATE OF ISSUE: AUGUST 2015
REVISED:	
DETAIL NUMBER: SS.21	

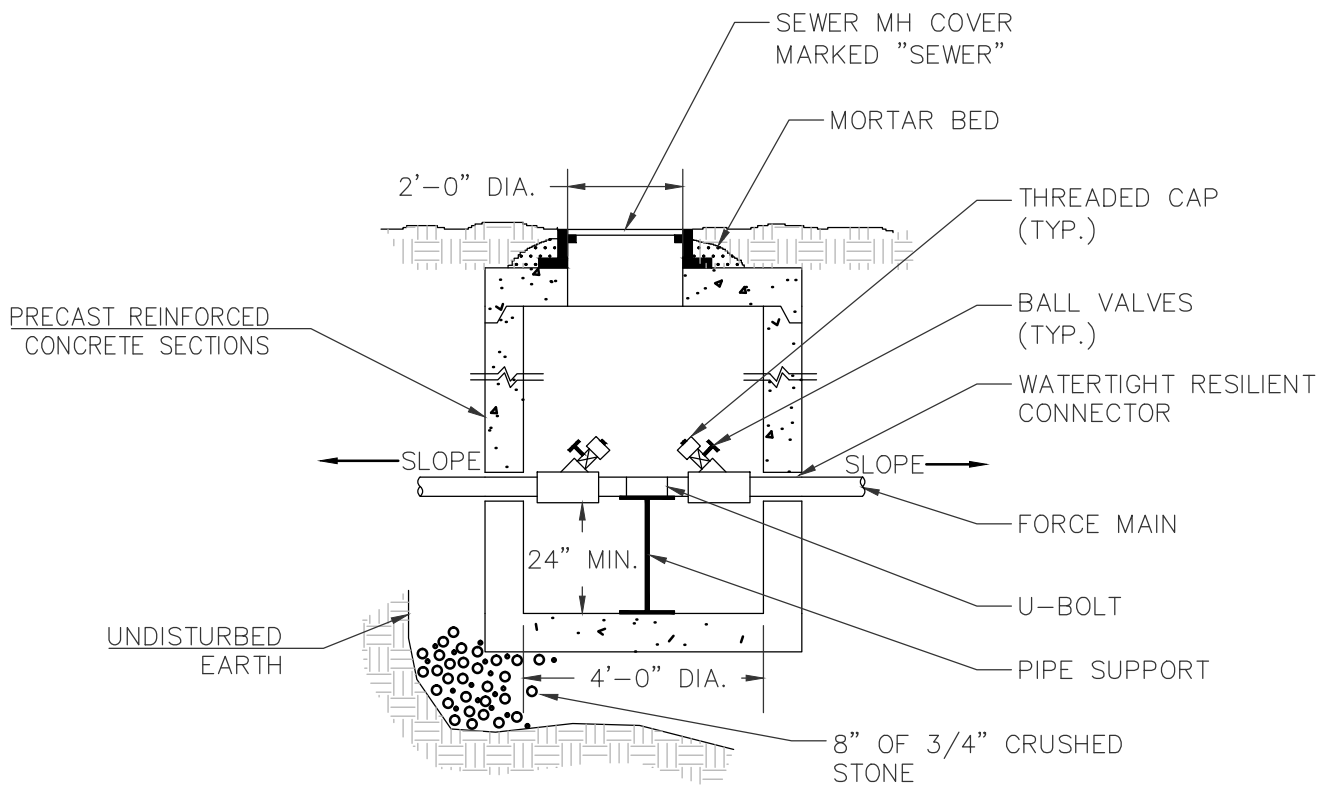

SECTION

**NOTES:**

1. PROVIDE MANHOLE STEPS 1'-0" O.C.
2. CONTRACTOR SHALL CONFIRM ELEVATION AND ALIGNMENT OF PROPOSED FORCE MAIN AND GROUND SURFACE AT EACH MANHOLE PRIOR TO ORDERING SECTION.
3. ADJUST FRAME TO GRADE WITH A MINIMUM OF TWO COURSES OF BRICK MASONRY OR REINFORCED CONCRETE GRADE RINGS (NOT SHOWN).
4. ALL EXTERIOR SURFACES OF GRADE ADJUSTMENT COURSES SHALL BE COVERED WITH 1/4" TO 3/8" MASONRY CEMENT PLASTER.



**DEDHAM DPW  
DESIGN & CONSTRUCTION STANDARDS**

FORCE MAIN CLEANOUT MANHOLE DETAIL

SCALE: NTS	DATE OF ISSUE: AUGUST 2015
---------------	-------------------------------

REVISED:

DETAIL NUMBER: SS.22
-------------------------

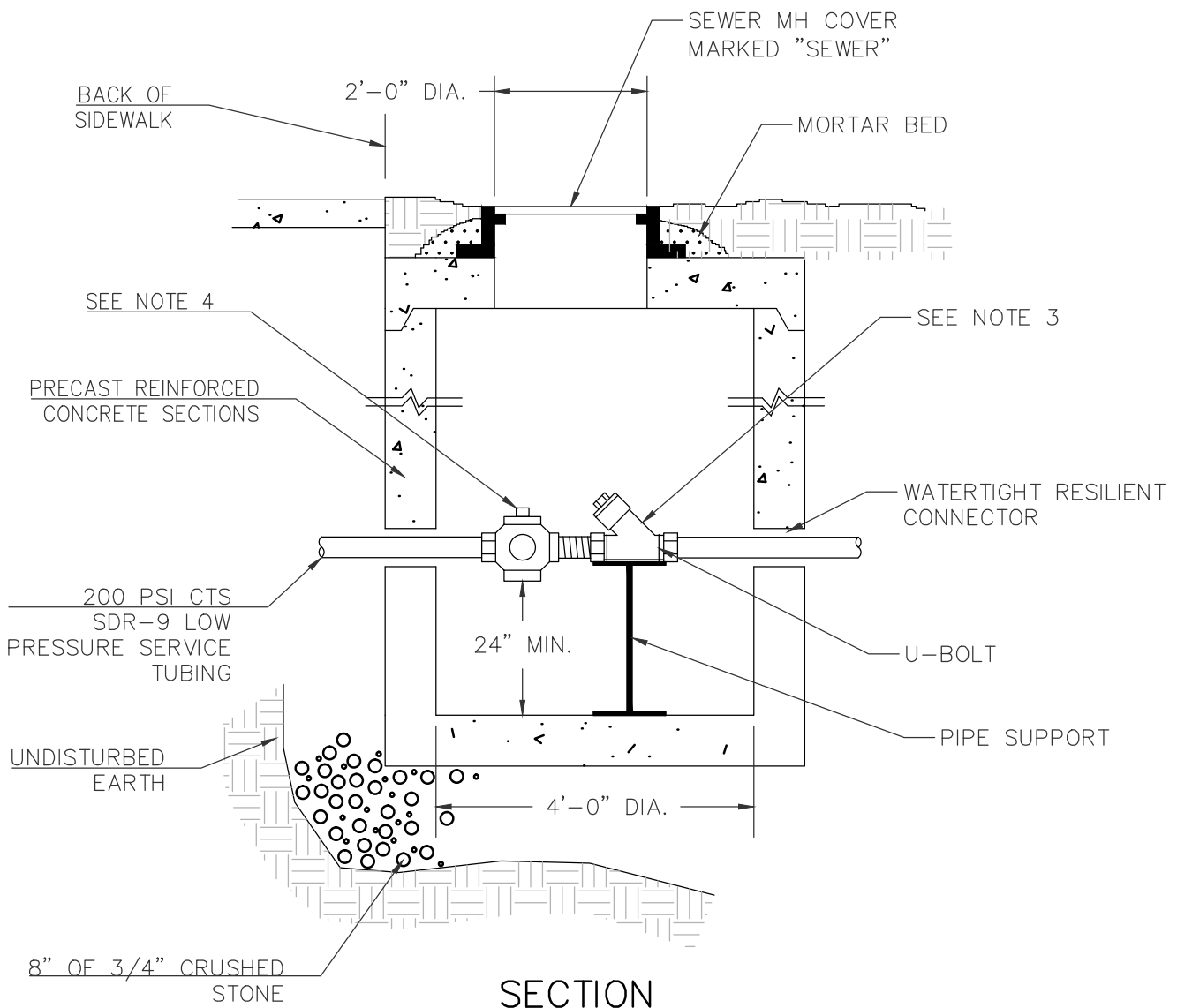

**SECTION**

**NOTES:**

1. PROVIDE MANHOLE STEPS 1'-0" O.C.
2. CONTRACTOR SHALL CONFIRM ELEVATION AND ALIGNMENT OF PROPOSED LOW PRESSURE SERVICE(S) AND GROUND SURFACE AT EACH MANHOLE PRIOR TO ORDERING SECTION.
3. SINKING BALL CHECK VALVE - FEMALE IPS X IPS (FLOMATIC MODEL 208, PART NO. 2142, OR EQUAL) W/ MUELLER 110 (OR EQUAL) COMPRESSION CONNECTION.
4. SHUT-OFF VALVE - IPT MUELLER 300 BALL CURB VALVE B-25122, OR EQUAL W/ MUELLER 110 (OR EQUAL) COMPRESSION CONNECTION.
5. ADJUST FRAME TO GRADE WITH A MINIMUM OF TWO COURSES OF BRICK MASONRY OR REINFORCED CONCRETE GRADE RINGS (NOT SHOWN).
6. ALL EXTERIOR SURFACES OF GRADE ADJUSTMENT COURSES SHALL BE COVERED WITH 1/4" TO 3/8" MASONRY CEMENT PLASTER.



**DEDHAM DPW  
DESIGN & CONSTRUCTION STANDARDS**

**LOW PRESSURE SEWER SERVICE  
VALVE BOX**

SCALE: NTS	DATE OF ISSUE: AUGUST 2015
---------------	-------------------------------

REVISED:

DETAIL NUMBER: SS.23
-------------------------



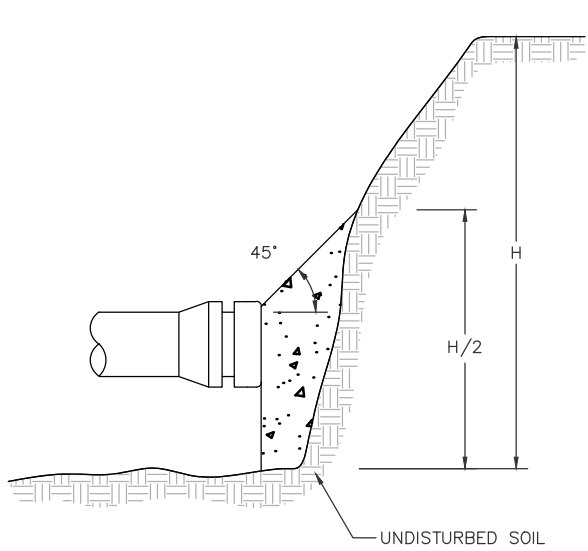

**PLUG / DEAD END - ELEVATION**

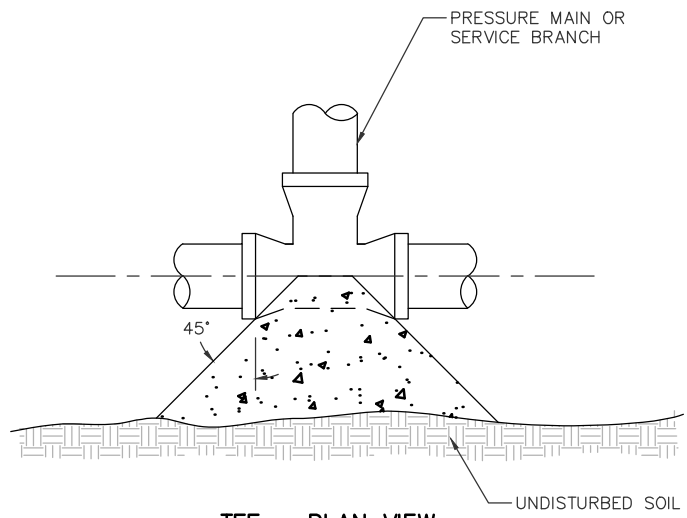

**TEE - PLAN VIEW**

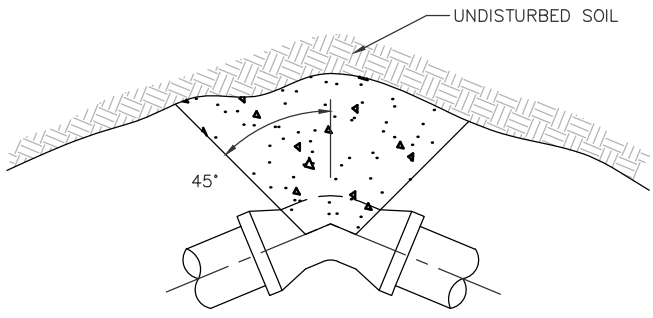

**ELBOW - PLAN VIEW**

**NOTES:**

1. THRUST BLOCKS SHALL BE Poured AGAINST UNDISTURBED SOILS USING FORMS AND 3,000 PSI CONCRETE.
2. CONCRETE SHALL NOT OBSTRUCT ANY BOLTS OR FLANGES.
3. THRUST AND BEARING AREA CALCULATIONS PERFORMED BY A PROFESSION ENGINEER LICENSED IN THE STATE OF MASSACHUSETTS MAY BE REQUIRED AT THE DISCRETION OF THE DIRECTOR OF ENGINEERING.



**DEDHAM DPW  
DESIGN & CONSTRUCTION STANDARDS**

**THRUST BLOCKS**

SCALE: NTS	DATE OF ISSUE: AUGUST 2015
REVISED:	
DETAIL NUMBER: SS.24	

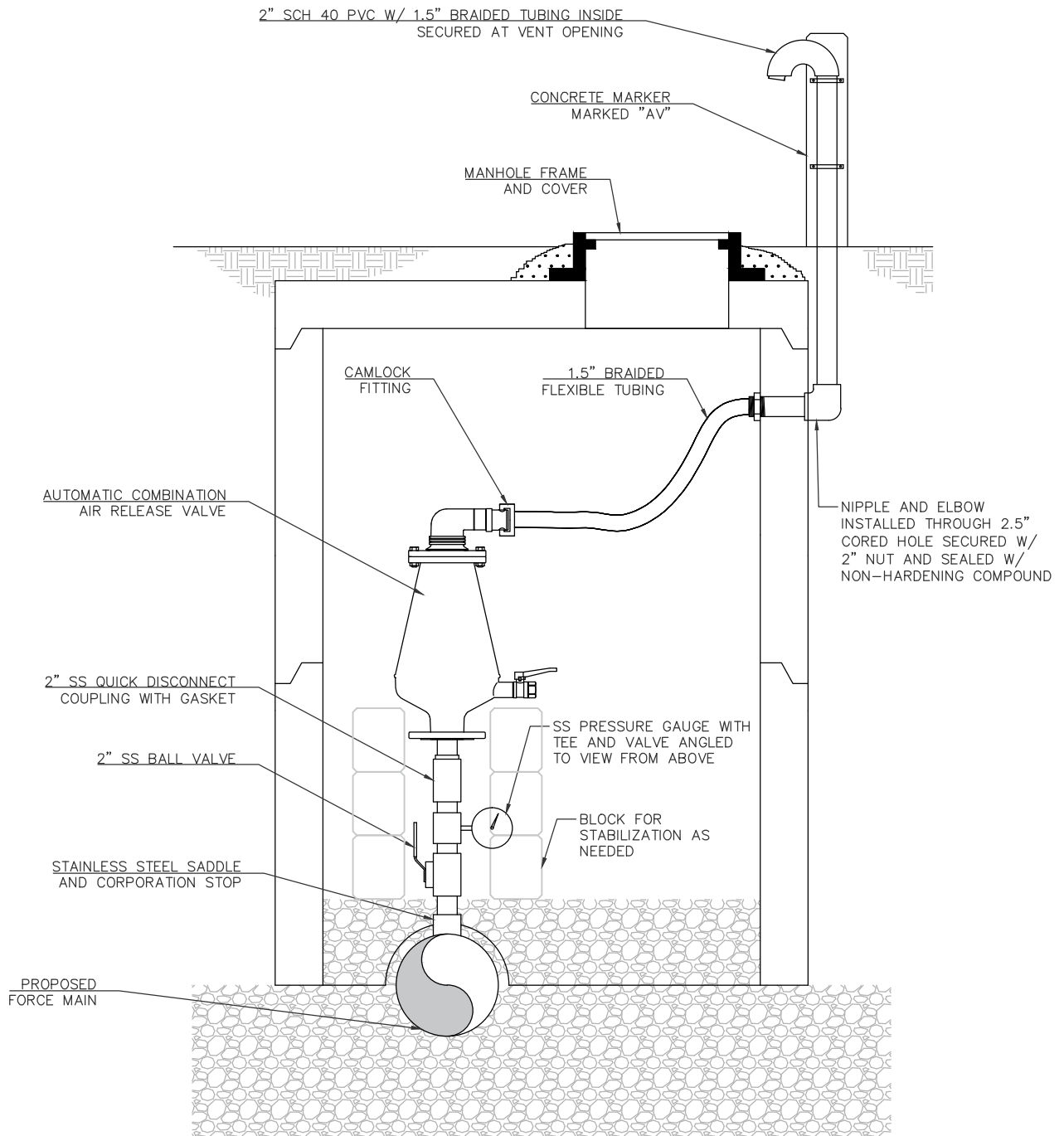

**NOTES:**

1. FORCE MAIN PROFILE AND ARV LOCATION TO BE ADJUSTED SUCH THAT ARV IS AT HIGH POINT WITH SUFFICIENT DEPTH FOR INSTALLATION AND TO PREVENT FREEZING.
3. ADJUST FRAME TO GRADE WITH A MINIMUM OF TWO COURSES OF BRICK MASONRY OR REINFORCED CONCRETE GRADE RINGS (NOT SHOWN).
4. ALL EXTERIOR SURFACES OF GRADE ADJUSTMENT COURSES SHALL BE COVERED WITH 1/4" TO 3/8" MASONRY CEMENT PLASTER.



**DEDHAM DPW  
DESIGN & CONSTRUCTION STANDARDS**

COMBINATION AIR RELEASE VALVE

SCALE: NTS	DATE OF ISSUE: AUGUST 2015
---------------	-------------------------------

REVISED:

DETAIL NUMBER: SS.25
-------------------------

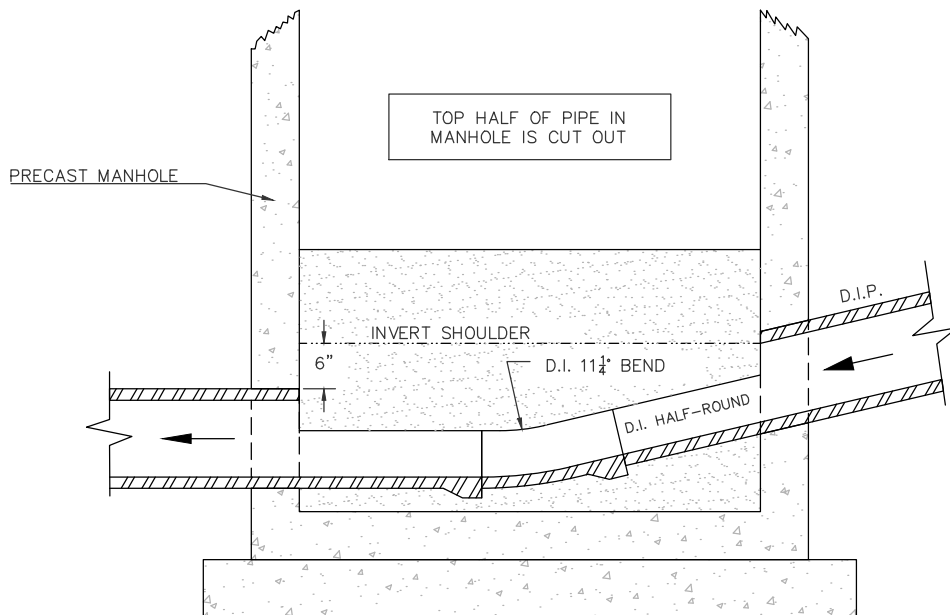
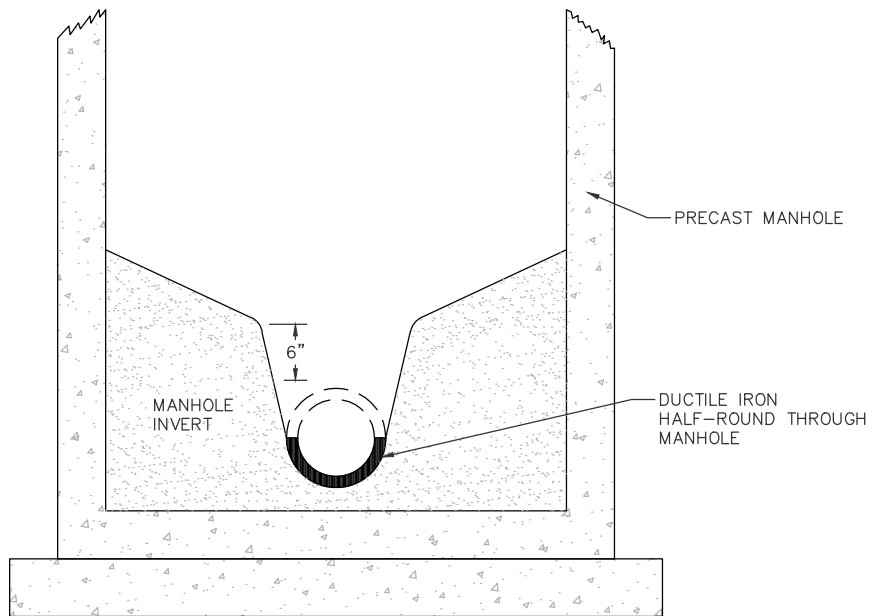

**NOTES:**

1. NO HORIZONTAL ALIGNMENT CHANGE CAN BE MADE WITHIN THIS MANHOLE TYPE. USE ON GRADES OF 10% OR GREATER.
2. EACH JOINT OF PIPE BETWEEN HIGH VELOCITY MANHOLE & MANHOLE UPGRADE SHALL HAVE A TRENCH DAM (SS.17).



**DEDHAM DPW  
DESIGN & CONSTRUCTION STANDARDS**

HIGH VELOCITY MANHOLE INVERT

SCALE: NTS	DATE OF ISSUE: AUGUST 2015
REVISED:	
DETAIL NUMBER: SS.26	

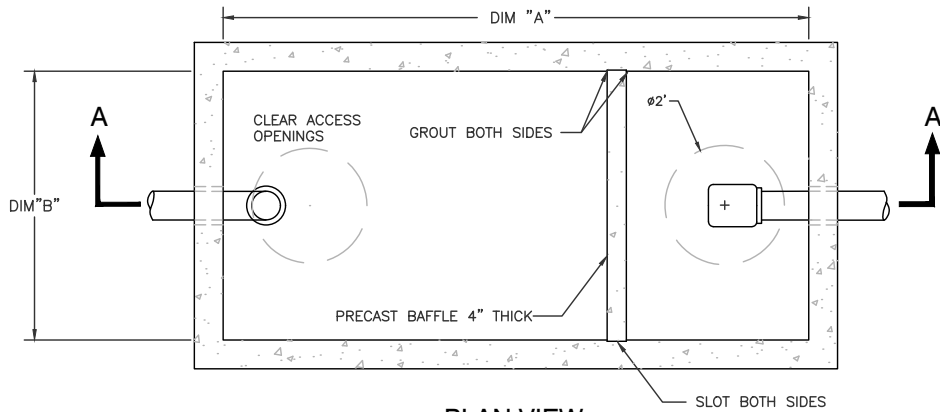

**PLAN VIEW**

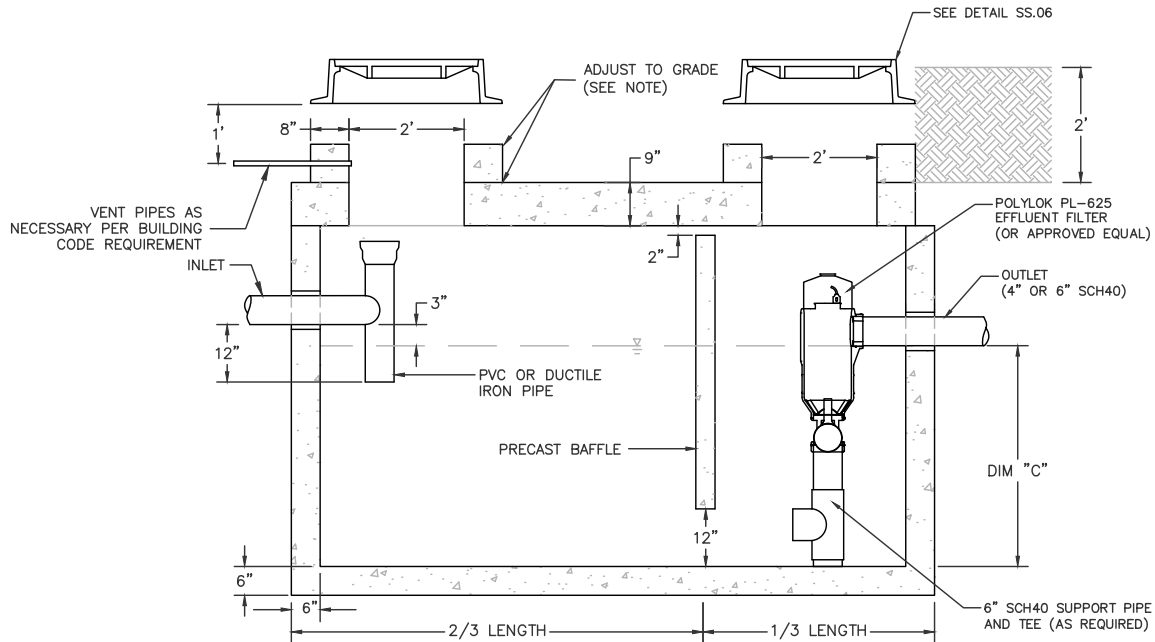

**SECTION A-A**

SIZING CHART			
GALLON CAPACITY	DIM "A"	DIM "B"	DIM "C"
1500 (MIN.)	120"	60"	48"
1750	120"	60"	58"
2000	144"	68"	48"
2500	144"	72"	56"
2750	144"	72"	62"
3000	168"	84"	50"
4000	168"	84"	66"
5000	216"	96"	56"
6000	216"	96"	68"

**NOTES:**

1. CONCRETE: 28 DAY F'c= 4500 psi
2. REBAR: ASTM A615 GRADE 60
3. MESH: ASTM A-185 GRADE 65
4. DESIGN: AC1318-83 BUILDING CODE  
ASTM C-857 MINIMUM STRUCTURAL DESIGN  
LOADING FOR UNDERGROUND PRECAST  
CONCRETE UTILITY STRUCTURES
5. LOADS: H-20 LOADING
6. FILL w/ CLEAN WATER PRIOR TO START UP OF SYSTEM
7. CONTRACTOR TO SUPPLY AND INSTALL ALL PIPING AND  
SANITARY TEES
8. GRAY WATER ONLY, BLACK WATER SHALL BE CARRIED BY  
SEPARATE SEWER
9. TRAP SIZE WILL BE BASED ON 15 GPD PER SEAT
10. LARGER SIZES MAY BE REQUIRED AS PER REVIEW OF FACILITY
11. WHERE COVER OVER GREASE TRAP EXCEEDS 2', 4' DIAMETER  
PRECAST CONE SECTIONS SHALL BE USED.
12. TOP, WALL, AND BASE THICKNESS MAY BE ADJUSTED AS  
NEEDED BY PRECASTER TO MEET H-20 LOADING.



**DEDHAM DPW  
DESIGN & CONSTRUCTION STANDARDS**

**STANDARD GREASE TRAP**

SCALE: DATE OF ISSUE:  
NTS AUGUST 2015

REVISED:  
7/26/2018

DETAIL NUMBER:  
SS.27

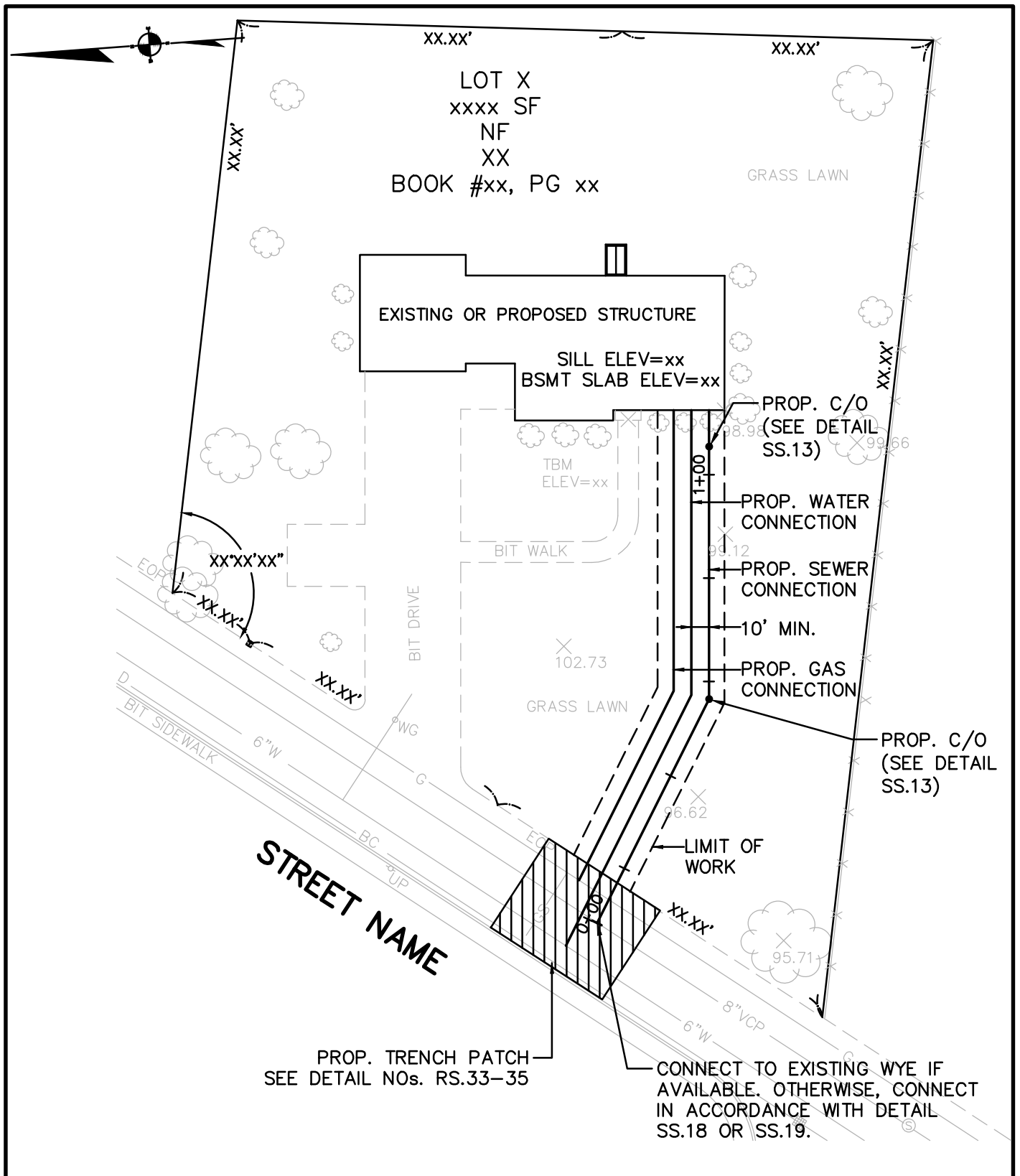

PROP. TRENCH PATCH  
SEE DETAIL NOS. RS.33-35

CONNECT TO EXISTING WYE IF  
AVAILABLE. OTHERWISE, CONNECT  
IN ACCORDANCE WITH DETAIL  
SS.18 OR SS.19.



**DEDHAM DPW  
DESIGN & CONSTRUCTION STANDARDS**

TYPICAL SEWER PLAN

SCALE: NTS	DATE OF ISSUE: AUGUST 2015
REVISED:	
DETAIL NUMBER: SS.28	

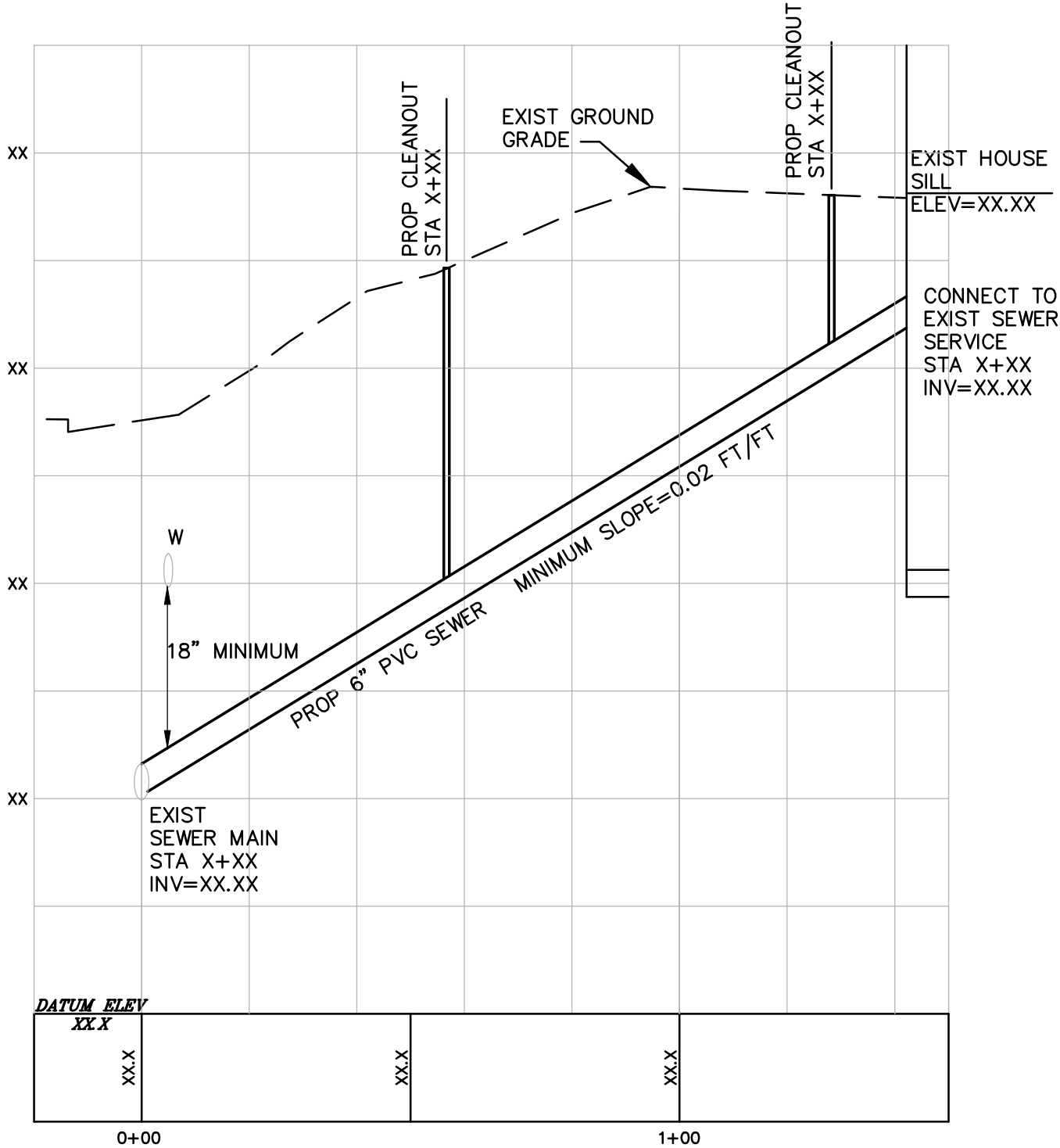

**DEDHAM DPW  
DESIGN & CONSTRUCTION STANDARDS**

TYPICAL SEWER PROFILE

SCALE: NTS	DATE OF ISSUE: AUGUST 2015
---------------	-------------------------------

REVISED:
----------

DETAIL NUMBER: SS.29
-------------------------

# MISCELLANEOUS

<b><u>DESCRIPTION</u></b>	<b><u>DETAIL NUMBER</u></b>
PARKING METER POST INSTALLATION	MISC.01
SIGN POST INSTALLATION	MISC.02
GRANITE BOUND AND COVER	MISC.03
CONCRETE BOUND AND COVER	MISC.04
TOWN STREET SIGNS	MISC.05
TOWN STREET SIGN INSTALLATION	MISC.06
CHAIN LINK FENCES (VARIOUS HEIGHTS)	MISC.07
HYDRANT & TAPPING SLEEVE VALVE	MISC.08
HYDRANT RELOCATION	MISC.09
STANDARD ANCHOR BASE LIGHT POLE	MISC.10
TRAFFIC SIGNAL CONDUIT TRENCH	MISC.11

UNLESS OTHERWISE NOTED, CONSTRUCTION METHODS, MATERIAL REQUIREMENTS AND METHOD OF MEASUREMENT SHALL BE IN ACCORDANCE WITH THE LATEST EDITION OF THE MASSACHUSETTS DEPARTMENT OF TRANSPORTATION (MassDOT) STANDARD SPECIFICATIONS.

ALSO REFERENCE CURRENT MassDOT CONSTRUCTION STANDARD DETAILS.



**DEDHAM DPW  
DESIGN & CONSTRUCTION STANDARDS**

DETAIL INDEX  
MISCELLANEOUS

SCALE: NTS	DATE OF ISSUE: AUGUST 2015
---------------	-------------------------------

REVISED:

DETAIL NUMBER: MISC-INDEX.01
---------------------------------

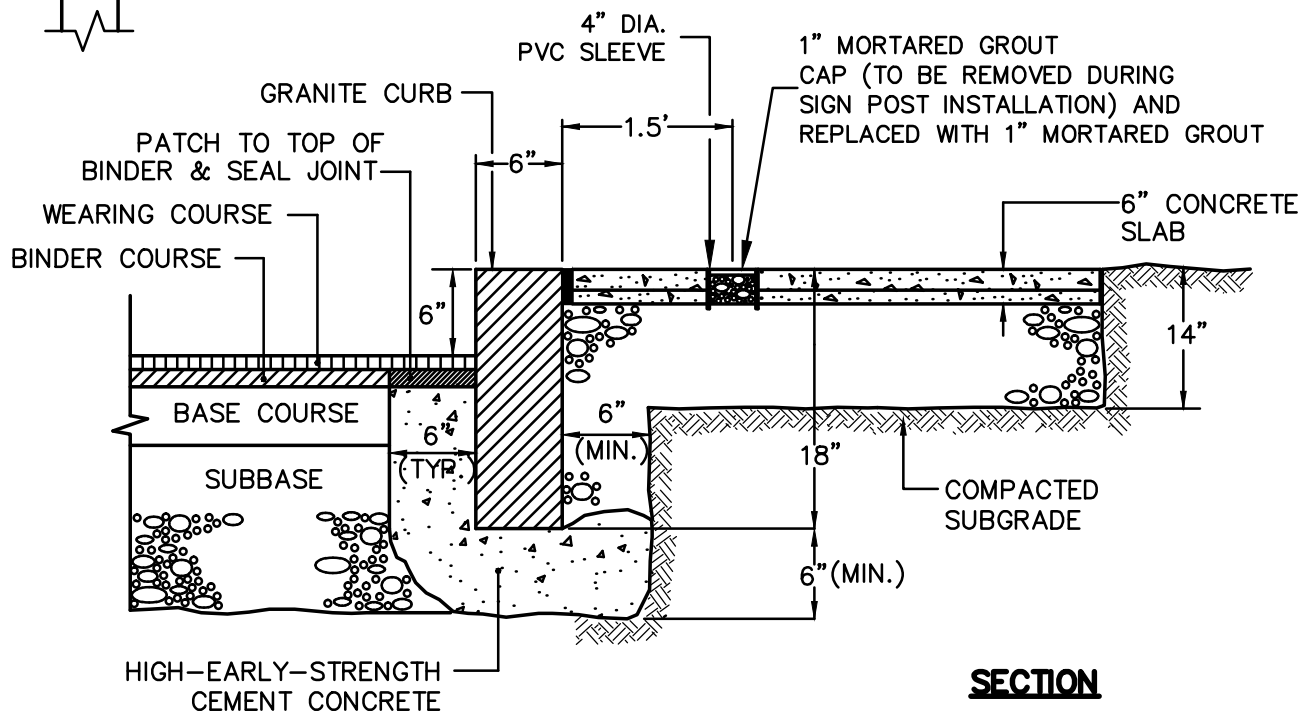
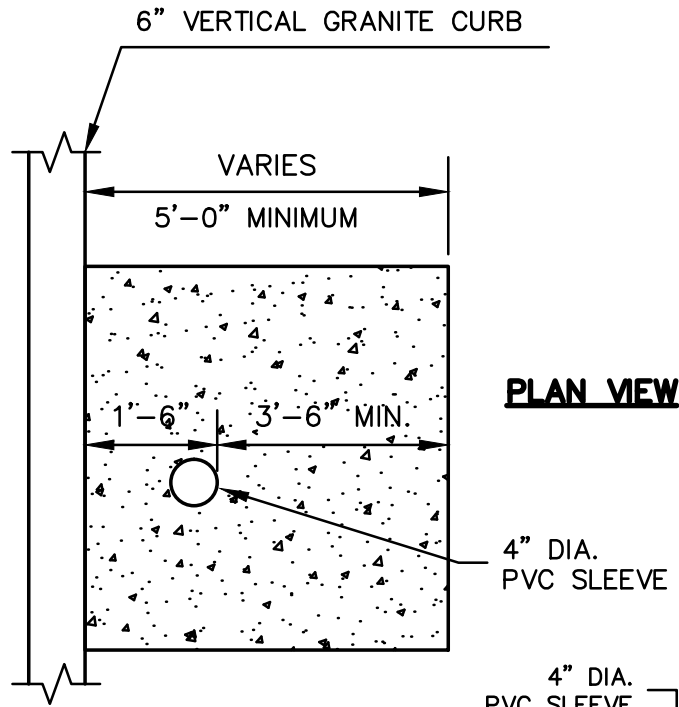

UNLESS OTHERWISE NOTED, CONSTRUCTION METHODS, MATERIAL REQUIREMENTS AND METHOD OF MEASUREMENT SHALL BE IN ACCORDANCE WITH THE LATEST EDITION OF THE MASSACHUSETTS DEPARTMENT OF TRANSPORTATION (MassDOT) STANDARD SPECIFICATIONS.

ALSO REFERENCE CURRENT MassDOT CONSTRUCTION STANDARD DETAILS.



**DEDHAM DPW  
DESIGN & CONSTRUCTION STANDARDS**

PARKING METER POST INSTALLATION

SCALE: NTS	DATE OF ISSUE: AUGUST 2015
---------------	-------------------------------

REVISED:

DETAIL NUMBER: MISC.01
---------------------------



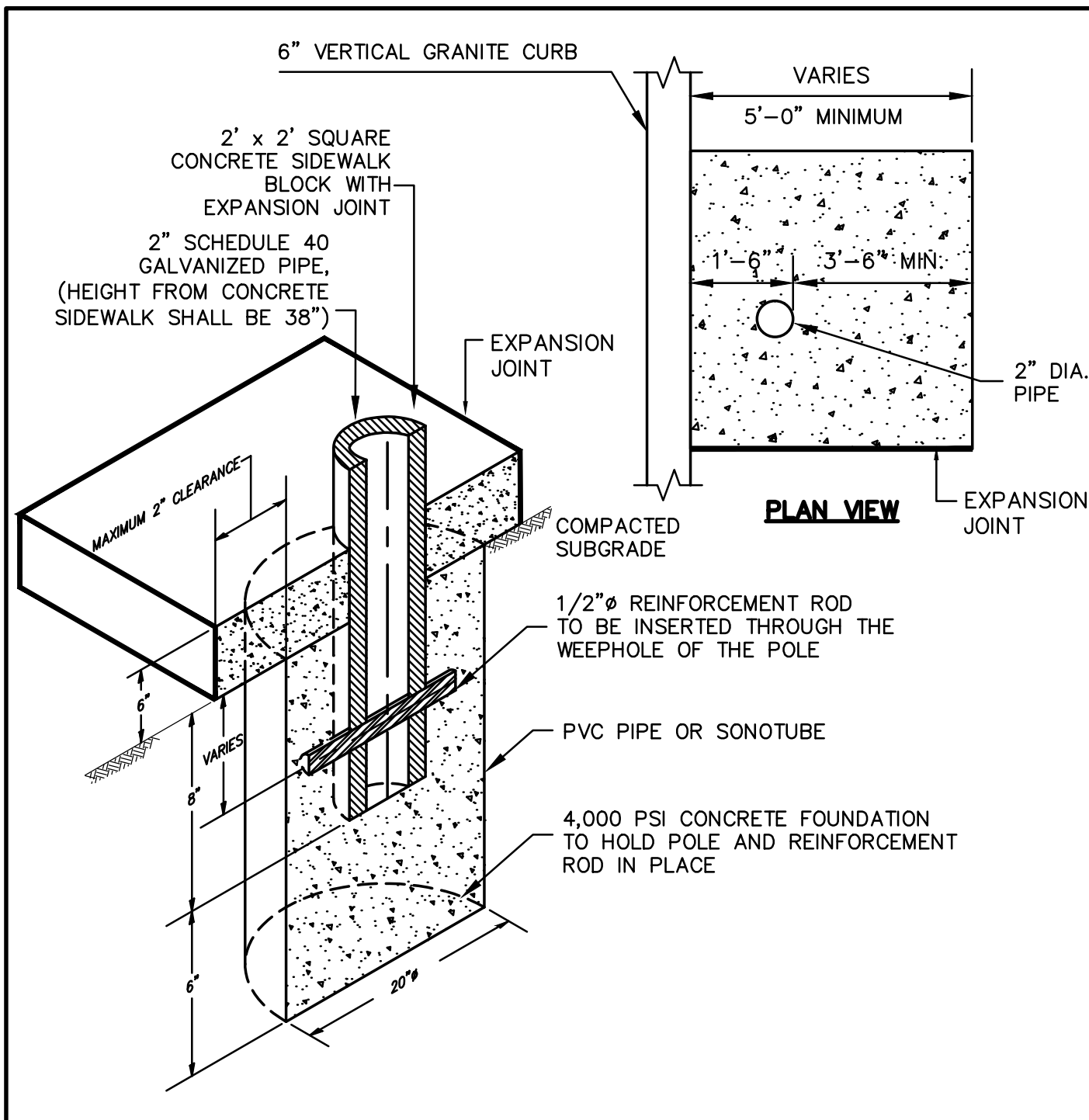

UNLESS OTHERWISE NOTED, CONSTRUCTION METHODS, MATERIAL REQUIREMENTS AND METHOD OF MEASUREMENT SHALL BE IN ACCORDANCE WITH THE LATEST EDITION OF THE MASSACHUSETTS DEPARTMENT OF TRANSPORTATION (MassDOT) STANDARD SPECIFICATIONS.

ALSO REFERENCE CURRENT MassDOT CONSTRUCTION STANDARD DETAILS.



**DEDHAM DPW  
DESIGN & CONSTRUCTION STANDARDS**

SIGN POST INSTALLATION  
IN SIDEWALK

SCALE: NTS	DATE OF ISSUE: AUGUST 2015
---------------	-------------------------------

REVISED:

DETAIL NUMBER: MISC.02
---------------------------

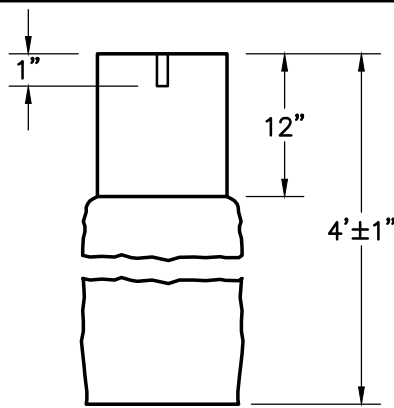

**SECTION**

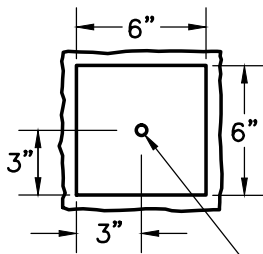

**PLAN**

1/2" DIA. HOLE IN CENTER OF TOP 1" DEEP.

**GRANITE BOUND**

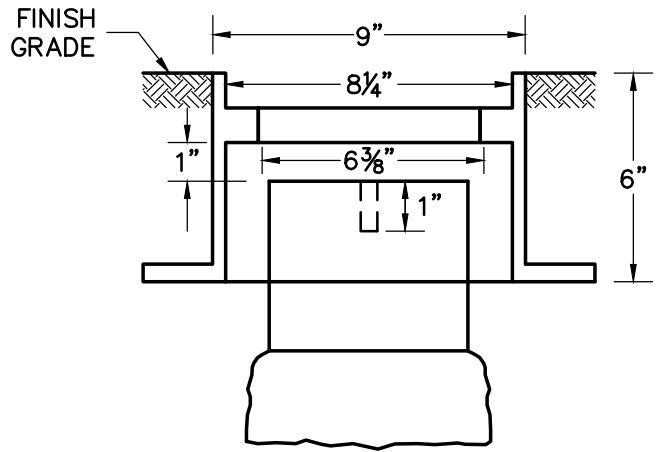

**SECTION**

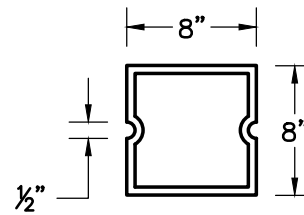

**PLAN**

**CAST IRON GRANITE BOUND COVER**

**NOTES:**

1. BOUNDS TO BE LOCATED IN LAWNS, SIDEWALKS OR DRIVES SHALL BE SET WITH THE TOP OF BOUND 2" BELOW GROUND SURFACE.
2. ALL BOUNDS SHALL BE SET AT THE DIRECTION OF ENGINEER. PRIOR TO COMMENCING THE WORK, THE CONTRACTOR SHALL NOTIFY THE ENGINEER.
3. ALL BOUNDS SHALL HAVE A LEBARON STONE BOUND FRAME AND COVER NO. S208-6, OR APPROVED EQUAL (SEE DETAIL).
4. THE TOP 12" OF THE BOUND IS TO BE MACHINE FINISHED.
5. ALL BOUNDS SHALL BE SET BY A REGISTERED LAND SURVEYOR IN THE COMMONWEALTH OF MASSACHUSETTS AND TIED TO NAD83 AND NAVD88 DATUMS.
6. ALL BOUNDS SHALL BE EMBEDDED BELOW GROUND SURFACE A MINIMUM OF 4'-0".

UNLESS OTHERWISE NOTED, CONSTRUCTION METHODS, MATERIAL REQUIREMENTS AND METHOD OF MEASUREMENT SHALL BE IN ACCORDANCE WITH THE LATEST EDITION OF THE MASSACHUSETTS DEPARTMENT OF TRANSPORTATION (MassDOT) STANDARD SPECIFICATIONS.

ALSO REFERENCE CURRENT MassDOT CONSTRUCTION STANDARD DETAILS.



**DEDHAM DPW  
DESIGN & CONSTRUCTION STANDARDS**

**GRANITE BOUND AND COVER**

SCALE: NTS      DATE OF ISSUE: AUGUST 2015

REVISED:

DETAIL NUMBER: MISC.03

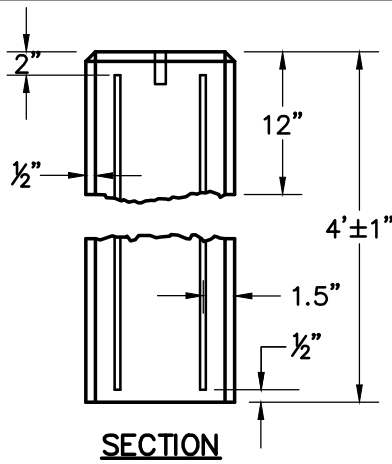

**SECTION**

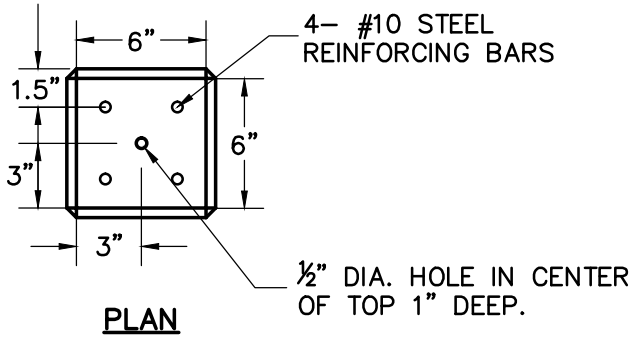

**PLAN**

**CONCRETE BOUND**

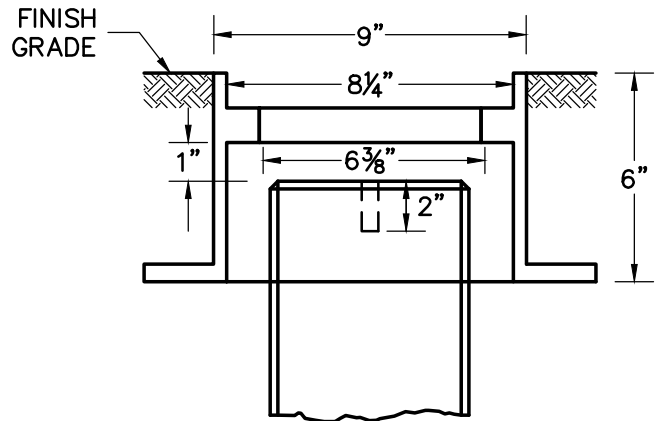

**SECTION**

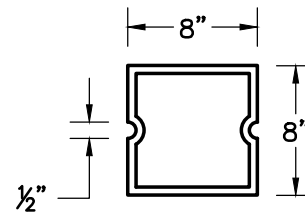

**PLAN**

**CAST IRON CONCRETE  
BOUND COVER**

**NOTES:**

1. BOUNDS TO BE LOCATED IN LAWNS, SIDEWALKS OR DRIVES SHALL BE SET WITH THE TOP OF BOUND 2" BELOW GROUND SURFACE.
2. ALL BOUNDS SHALL BE SET AT THE DIRECTION OF ENGINEER. PRIOR TO COMMENCING THE WORK, THE CONTRACTOR SHALL NOTIFY THE ENGINEER.
3. ALL BOUNDS SHALL HAVE A LEBARON STONE BOUND FRAME AND COVER NO. S208-6, OR APPROVED EQUAL (SEE DETAIL).
4. ALL BOUNDS SHALL BE SET BY A REGISTERED LAND SURVEYOR IN THE COMMONWEALTH OF MASSACHUSETTS AND TIED TO NAD83 AND NAVD88 DATUMS.
5. ALL BOUNDS SHALL BE EMBEDDED BELOW GROUND SURFACE A MINIMUM OF 4'-0".

UNLESS OTHERWISE NOTED, CONSTRUCTION METHODS, MATERIAL REQUIREMENTS AND METHOD OF MEASUREMENT SHALL BE IN ACCORDANCE WITH THE LATEST EDITION OF THE MASSACHUSETTS DEPARTMENT OF TRANSPORTATION (MassDOT) STANDARD SPECIFICATIONS.

ALSO REFERENCE CURRENT MassDOT CONSTRUCTION STANDARD DETAILS.



**DEDHAM DPW  
DESIGN & CONSTRUCTION STANDARDS**

**CONCRETE BOUND AND COVER**

SCALE: DATE OF ISSUE:  
NTS AUGUST 2015

REVISED:

DETAIL NUMBER:  
MISC.04

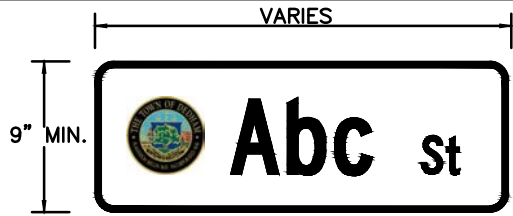

MAIN STREET – GREEN BACKGROUND WITH WHITE LETTERING & TOWN SEAL (6" DIA.) ON LEFT SIDE (TO BE USED ON MAIN ROADS, SIGNALIZED INTERSECTIONS OR OTHER ROADS AS DIRECTED BY THE DPW DIRECTOR).



PUBLIC WAY MINOR STREET – GREEN BACKGROUND WITH WHITE LETTERING



PRIVATE WAY – BLUE BACKGROUND WITH WHITE LETTERING



PRIVATE DRIVE – BROWN BACKGROUND WITH WHITE LETTERING

NOTES:

1. LETTERING ON SIGNS SHOULD CONSIST OF HIGHWAY B (MIN.) LETTERING WITH INITIAL UPPER-CASE LETTERS AT LEAST 6" IN HEIGHT AND LOWER-CASE LETTERS AT LEAST 4.5" IN HEIGHT.
2. SUPPLEMENTARY LETTERING (i.e., St, Rd, Dr, etc) SHOULD CONSIST OF HIGHWAY B LETTERING WITH INITIAL UPPER-CASE LETTERS AT LEAST 3" IN HEIGHT AND LOWER-CASE LETTERS AT LEAST 2.25" IN HEIGHT.
3. ABBREVIATIONS FOR PRIVATE WAYS (PVT WAY) AND PRIVATE DRIVES (PVT DR) SHOULD CONSIST OF HIGHWAY B LETTERING ALL IN UPPER-CASE LETTERS AT LEAST 3" IN HEIGHT.
4. LETTER SPACING SHOULD BE IN CONFORMANCE WITH THE LATEST EDITION OF THE M.U.T.C.D.

UNLESS OTHERWISE NOTED, CONSTRUCTION METHODS, MATERIAL REQUIREMENTS AND METHOD OF MEASUREMENT SHALL BE IN ACCORDANCE WITH THE LATEST EDITION OF THE MASSACHUSETTS DEPARTMENT OF TRANSPORTATION (MassDOT) STANDARD SPECIFICATIONS.

ALSO REFERENCE CURRENT MassDOT CONSTRUCTION STANDARD DETAILS.



**DEDHAM DPW  
DESIGN & CONSTRUCTION STANDARDS**

TOWN STREET SIGNS

SCALE: NTS	DATE OF ISSUE: AUGUST 2015
---------------	-------------------------------

REVISED:

DETAIL NUMBER: MISC.05
---------------------------

\* - 2' MIN FOR NO SIDEWALK &  
3' MIN WITH SIDEWALK

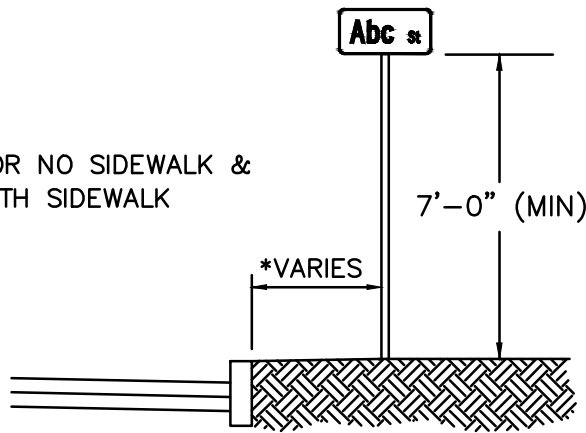

**SIGN INSTALLATION**

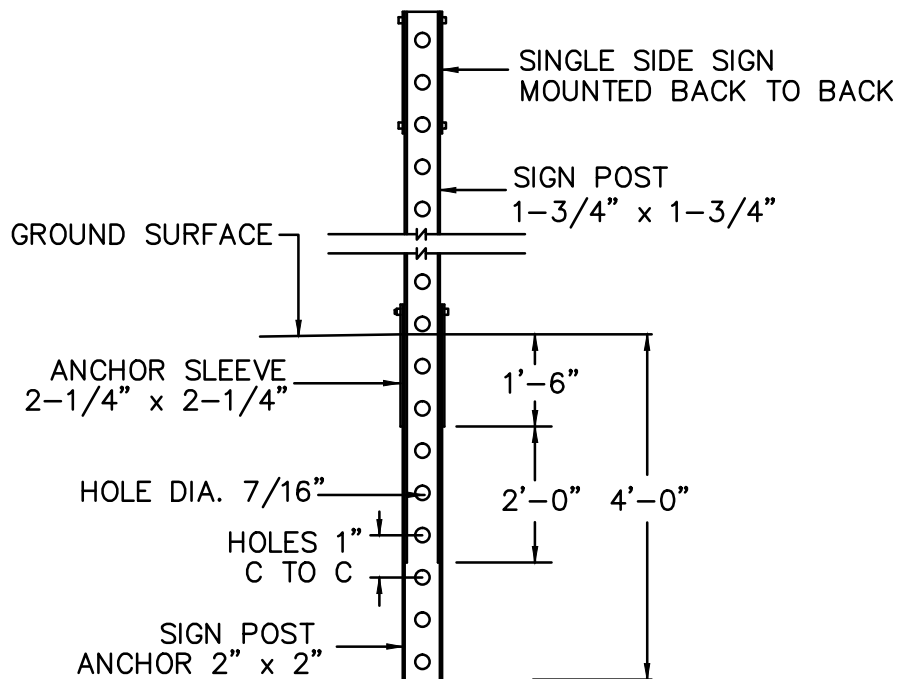

**P-5 TELESCOPIC POST**

UNLESS OTHERWISE NOTED, CONSTRUCTION METHODS, MATERIAL REQUIREMENTS AND METHOD OF MEASUREMENT SHALL BE IN ACCORDANCE WITH THE LATEST EDITION OF THE MASSACHUSETTS DEPARTMENT OF TRANSPORTATION (MassDOT) STANDARD SPECIFICATIONS.

ALSO REFERENCE CURRENT MassDOT CONSTRUCTION STANDARD DETAILS.



**DEDHAM DPW  
DESIGN & CONSTRUCTION STANDARDS**

TOWN STREET SIGN  
INSTALLATION

SCALE: NTS	DATE OF ISSUE: AUGUST 2015
---------------	-------------------------------

REVISED:

DETAIL NUMBER: MISC.06
---------------------------

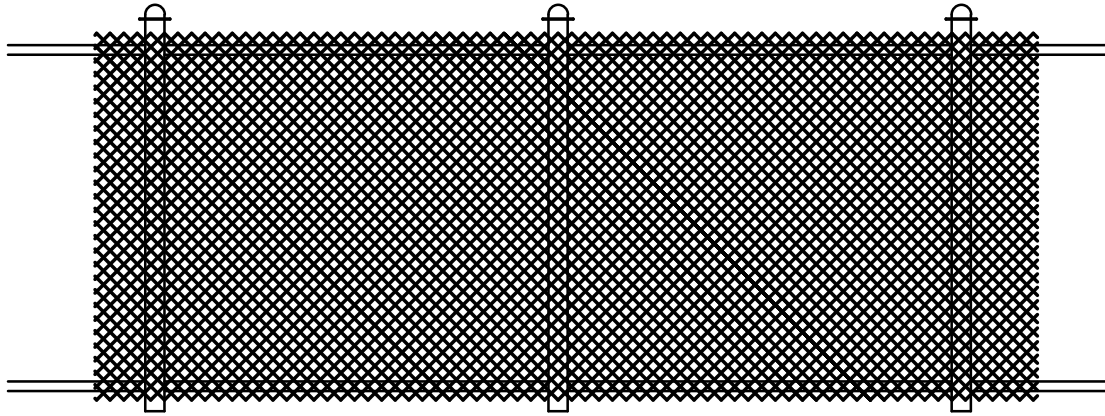

NOTES:

1. ALL CHAIN LINK FENCING MATERIAL SHALL BE BLACK VINYL COATED UNLESS OTHERWISE SPECIFIED.

UNLESS OTHERWISE NOTED, CONSTRUCTION METHODS, MATERIAL REQUIREMENTS AND METHOD OF MEASUREMENT SHALL BE IN ACCORDANCE WITH THE LATEST EDITION OF THE MASSACHUSETTS DEPARTMENT OF TRANSPORTATION (MassDOT) STANDARD SPECIFICATIONS.

ALSO REFERENCE CURRENT MassDOT CONSTRUCTION STANDARD DETAILS.



**DEDHAM DPW  
DESIGN & CONSTRUCTION STANDARDS**

CHAIN LINK FENCE  
VARIOUS HEIGHTS

SCALE: NTS	DATE OF ISSUE: AUGUST 2015
---------------	-------------------------------

REVISED:

DETAIL NUMBER: MISC.07
---------------------------

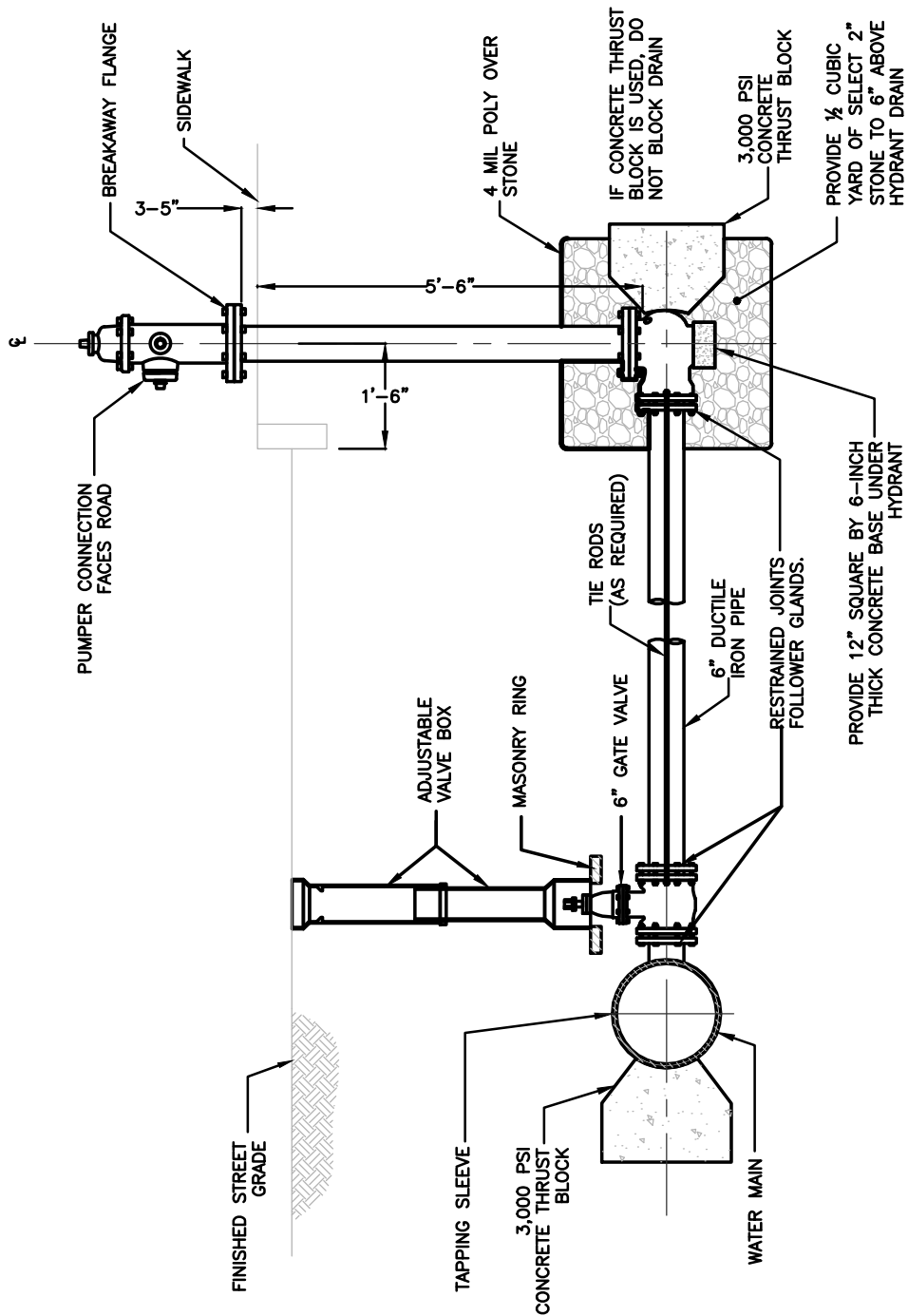

**NOTES:**

- CONCRETE THRUST BLOCK TO BE USED ONLY WHERE IT WILL BEAR ON UNDISTURBED EARTH.
- USE RESTRAINED JOINT FOLLOWER GLANDS, OR TIE RODS WHERE CONCRETE THRUST BLOCK IS UNACCEPTABLE.
- SIZE OF BLOCK OR FITTING TO BE DESIGNED FOR SPECIFIC CONDITIONS, OR ANY NECESSARY BENDS.
- VALVES SHALL OPEN RIGHT (CLOCKWISE)
- HYDRANTS SHALL OPEN LEFT (COUNTERCLOCKWISE)
- DEDHAM--WESTWOOD WATER DISTRICT STANDARDS SUPERCEDE THIS DETAIL.

UNLESS OTHERWISE NOTED, CONSTRUCTION METHODS, MATERIAL REQUIREMENTS AND METHOD OF MEASUREMENT SHALL BE IN ACCORDANCE WITH THE LATEST EDITION OF THE MASSACHUSETTS DEPARTMENT OF TRANSPORTATION (MassDOT) STANDARD SPECIFICATIONS.

ALSO REFERENCE CURRENT MassDOT CONSTRUCTION STANDARD DETAILS.



**DEDHAM DPW  
DESIGN & CONSTRUCTION STANDARDS**

**HYDRANT & TAPPING SLEEVE VALVE**

SCALE: NTS	DATE OF ISSUE: AUGUST 2015
REVISED:	
DETAIL NUMBER: MISC.08	

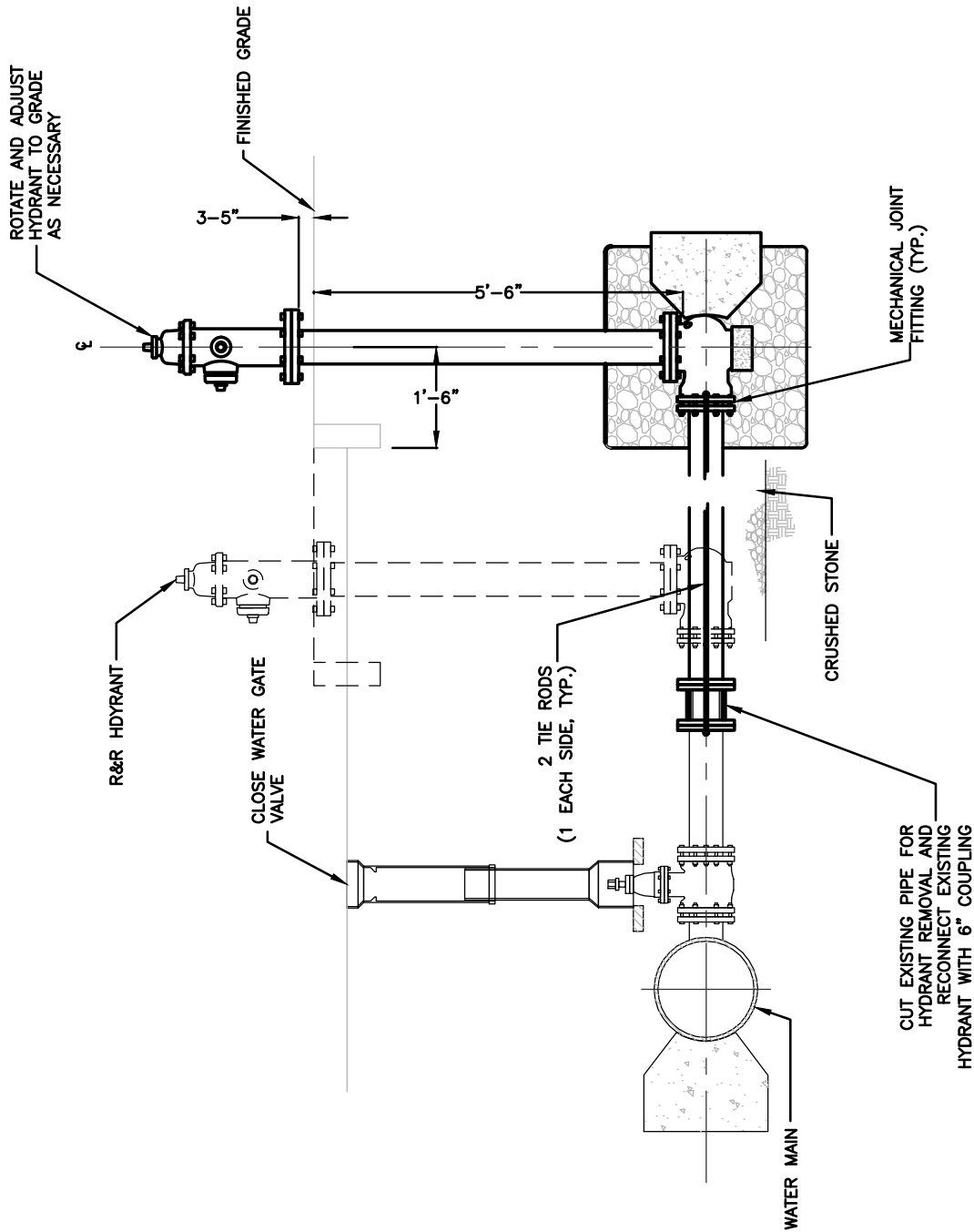

- NOTES:**
- ALL OTHER ASPECTS OF DETAIL TO MATCH DETAIL MISC.08.
  - DEDHAM-WESTWOOD WATER DISTRICT STANDARDS SUPERCEDE THIS DETAIL.

UNLESS OTHERWISE NOTED, CONSTRUCTION METHODS, MATERIAL REQUIREMENTS AND METHOD OF MEASUREMENT SHALL BE IN ACCORDANCE WITH THE LATEST EDITION OF THE MASSACHUSETTS DEPARTMENT OF TRANSPORTATION (MassDOT) STANDARD SPECIFICATIONS.

ALSO REFERENCE CURRENT MassDOT CONSTRUCTION STANDARD DETAILS.



**DEDHAM DPW  
DESIGN & CONSTRUCTION STANDARDS**

HYDRANT RELOCATION

SCALE: NTS	DATE OF ISSUE: AUGUST 2015
REVISED:	
DETAIL NUMBER: MISC.09	



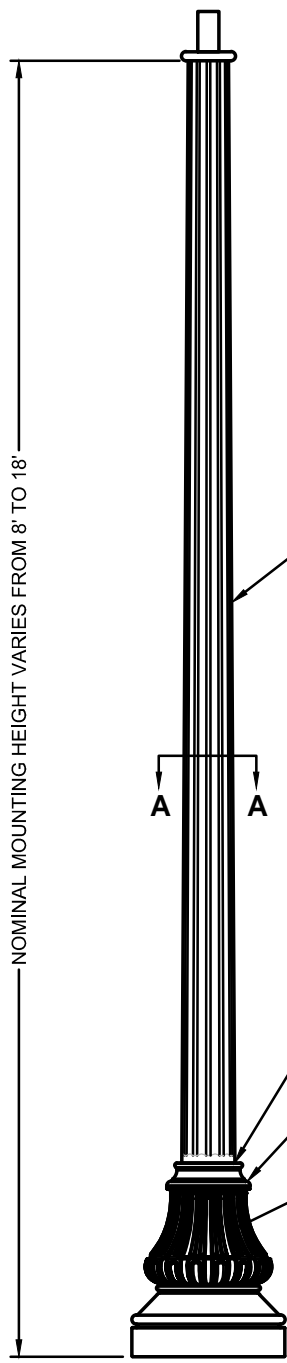

NOMINAL MOUNTING HEIGHT VARIES FROM 8' TO 18'

LIGHT POLE SHAFT FABRICATED FROM 6063-T4 ALUMINUM TUBE (LIGHT POLE ASSEMBLY IS HEAT TREATED TO T6 CONDITION AFTER WELDING)

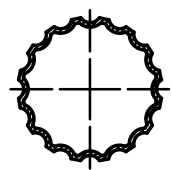

**SECTION A-A**  
16 FLAT FLUTE

6" O.D. x .188" WALL @ POLE BOTTOM

CAST ALUMINUM WASHINGTON DECORATIVE ANCHOR BASE SEE "BASE DETAIL" & "DETAIL B"

4" x 6" ALUMINUM HANDHOLE DOOR

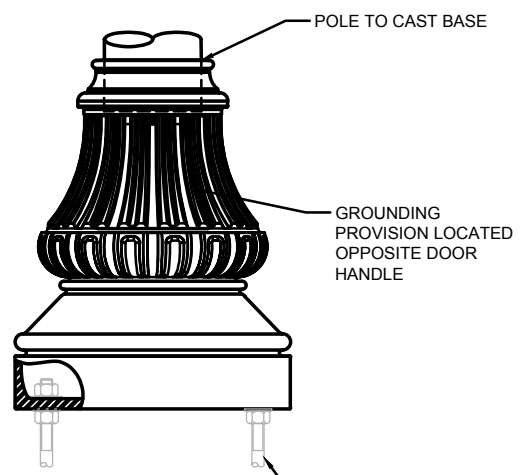

**BASE DETAIL**

POLE TO CAST BASE  
GROUNDING PROVISION LOCATED OPPOSITE DOOR HANDLE  
(4) 3/4"-10 x 17" LG. ANCHOR BOLTS

CENTERLINE OF HANDHOLE

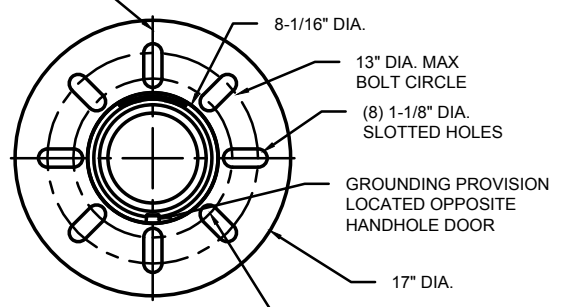

**DETAIL B**  
(BOTTOM VIEW)

8-1/16" DIA.  
13" DIA. MAX BOLT CIRCLE  
(8) 1-1/8" DIA. SLOTTED HOLES  
GROUNDING PROVISION LOCATED OPPOSITE HANDHOLE DOOR  
17" DIA.  
9-13/16" MIN BOLT CIRCLE

**NOTES:**

1. LIGHT POLE BASE SHALL BE A VALMONT WASHINGTON BASE LIGHT POLE (WA17-AS) OR APPROVED EQUAL WITH A BLACK POWDERED PAINT FINISH.
2. ANCHOR BOLTS SHALL BE FULLY GALVANIZED WITH A MINIMUM YIELD STRENGTH OF 55 KSI.

UNLESS OTHERWISE NOTED, CONSTRUCTION METHODS, MATERIAL REQUIREMENTS AND METHOD OF MEASUREMENT SHALL BE IN ACCORDANCE WITH THE LATEST EDITION OF THE MASSACHUSETTS DEPARTMENT OF TRANSPORTATION (MassDOT) STANDARD SPECIFICATIONS.

ALSO REFERENCE CURRENT MassDOT CONSTRUCTION STANDARD DETAILS.



**DEDHAM DPW  
DESIGN & CONSTRUCTION STANDARDS**

STANDARD ANCHOR BASE LIGHT POLE

SCALE: NTS	DATE OF ISSUE: AUGUST 2015
REVISED:	
DETAIL NUMBER: MISC.10	

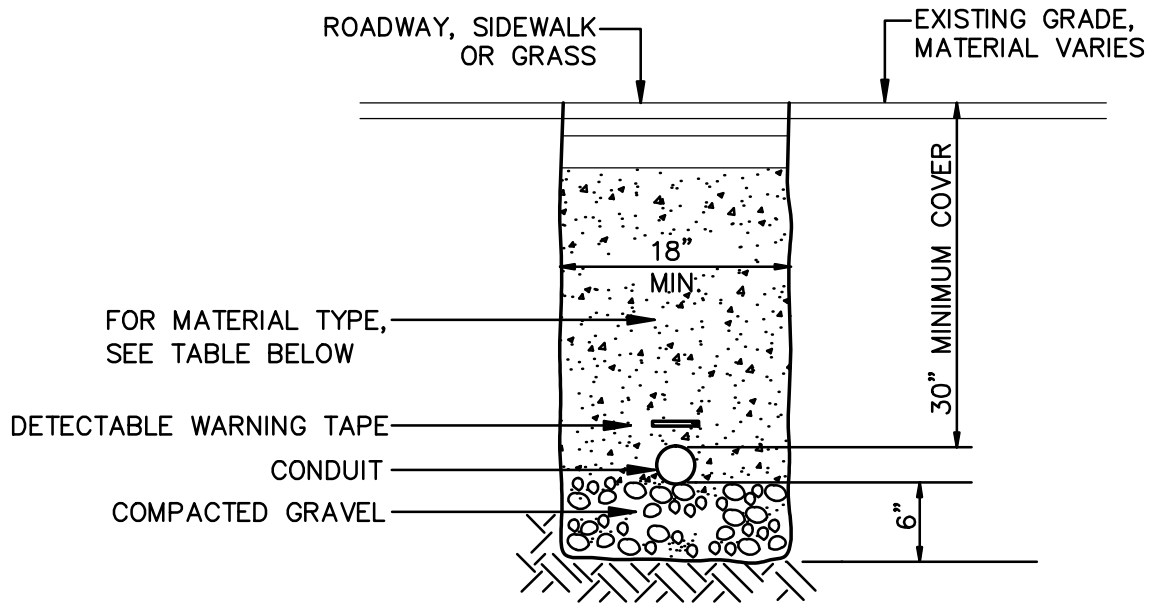

MATERIAL TYPE		
UNDER ROADWAY	UNDER SIDEWALK	UNDER GRASS
CONTROLLED DENSITY FILL (MassDOT SPECIFICATION M4.08.0, TYPE "1E" OR "2E", SEE SPECIAL PROVISIONS)	MassDOT COMPACTED GRAVEL BORROW M1.03.0 (TYPE "B")	MassDOT COMPACTED GRAVEL BORROW M1.03.0 (TYPE "B")

NOTE:  
 FLOWABLE FILL MIX TRENCH REQUIRED ONLY IN AREAS OF EXISTING ROADWAY PAVEMENT THAT DO NOT REQUIRE FULL DEPTH CONSTRUCTION

UNLESS OTHERWISE NOTED, CONSTRUCTION METHODS, MATERIAL REQUIREMENTS AND METHOD OF MEASUREMENT SHALL BE IN ACCORDANCE WITH THE LATEST EDITION OF THE MASSACHUSETTS DEPARTMENT OF TRANSPORTATION (MassDOT) STANDARD SPECIFICATIONS.

ALSO REFERENCE CURRENT MassDOT CONSTRUCTION STANDARD DETAILS.



**DEDHAM DPW  
 DESIGN & CONSTRUCTION STANDARDS**

TRAFFIC SIGNAL CONDUIT TRENCH

SCALE: NTS  
 DATE OF ISSUE: AUGUST 2015

REVISED:

DETAIL NUMBER: MISC.11

ATTACHMENT E –

MASSACHUSETTS HIGHWAY DEPARTMENT WHEELCHAIR RAMP STANDARDS

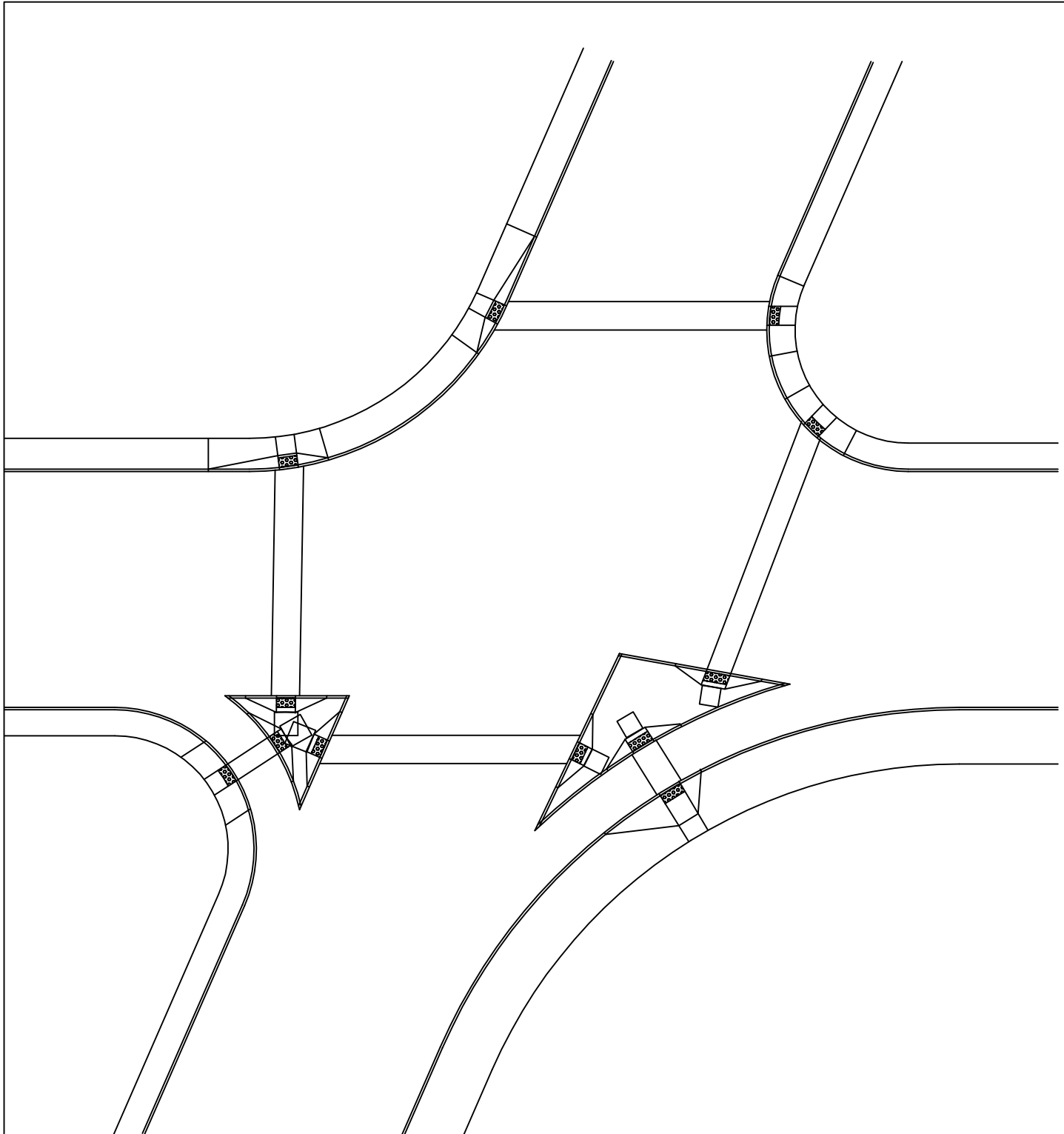

**NOTES:**

1. LEVEL LANDINGS CAN OVERLAP
2. ISLAND AREAS SUBJECT TO TRAVEL SHOULD BE TREATED AS PLAZAS "NOT MORE THAN 2% SLOPE IN ANY DIRECTION"
3. ALL RAMPS BY REGULATION MUST BE PERPENDICULAR TO THE CURB AT THE GUTTER
4. RAMPS SHOULD BE BOTH ALIGNED TOWARD THE RECEIVING RAMP AND WITHIN THE GENERALLY PREFERRED PEDESTRIAN PHASE OF TRAFFIC

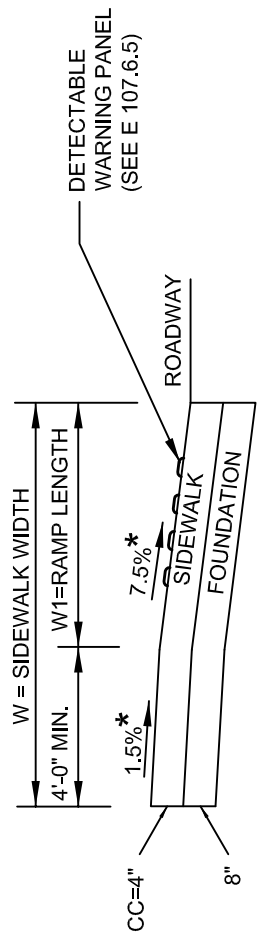
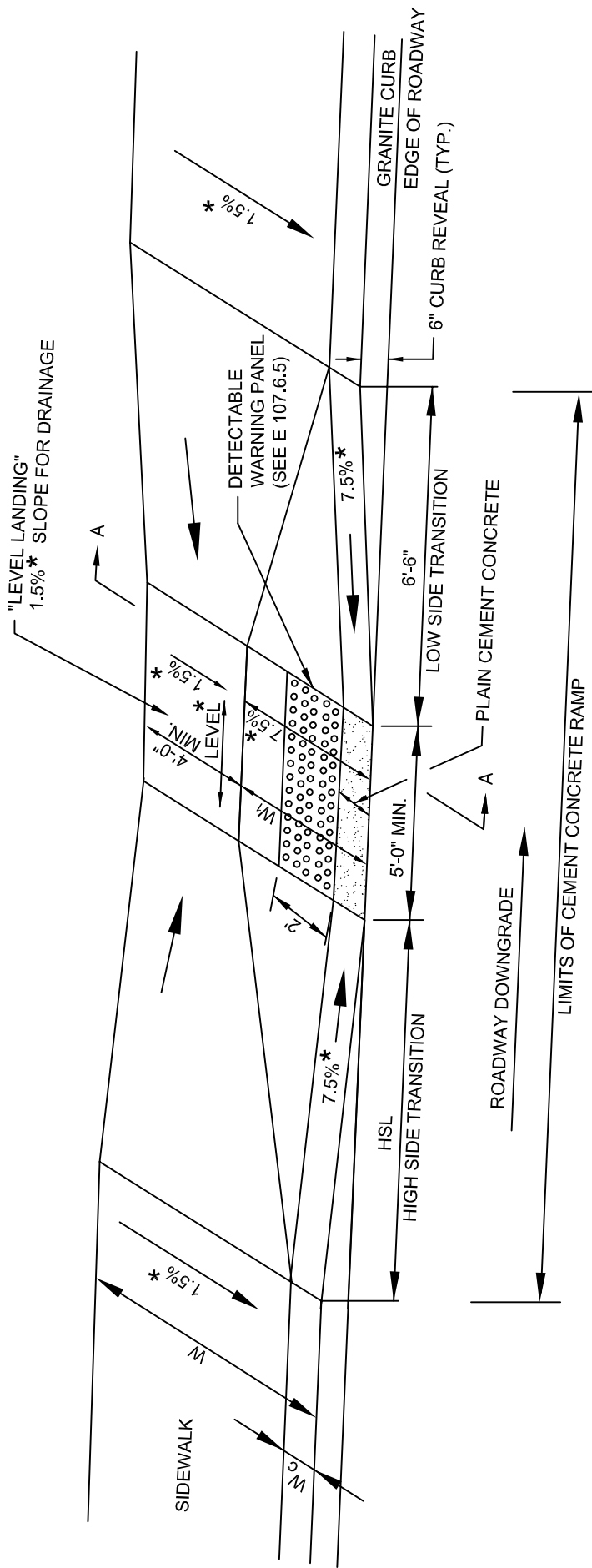

**LEGEND**

- HSL = HIGH SIDE TRANSITION LENGTH (SEE E 107.9.0)
  - W = SIDEWALK WIDTH
  - W<sub>C</sub> = CURB WIDTH
  - W<sub>1</sub> = PERPENDICULAR RAMP LENGTH
  - CC = CEMENT CONCRETE
  - \* = TOLERANCE FOR CONSTRUCTION ±0.5%
- USABLE SIDEWALK WIDTH PER AAB = W-W<sub>C</sub>  
 RAMP LENGTH, W<sub>1</sub> = W-4'-0" Min

**SECTION A-A**



**WHEELCHAIR RAMPS  
 LESS THAN 12'-4" SIDEWALK**

DATE OF ISSUE  
 OCTOBER 2017

DRAWING NUMBER  
**E 107.2.0**

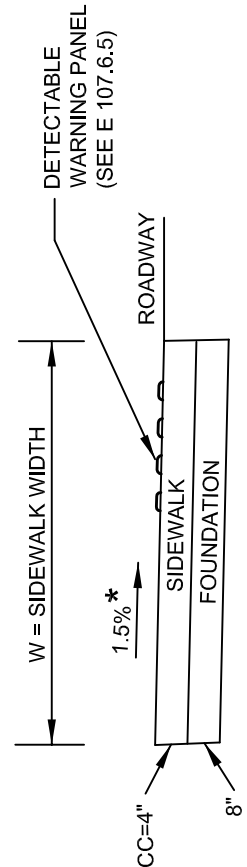
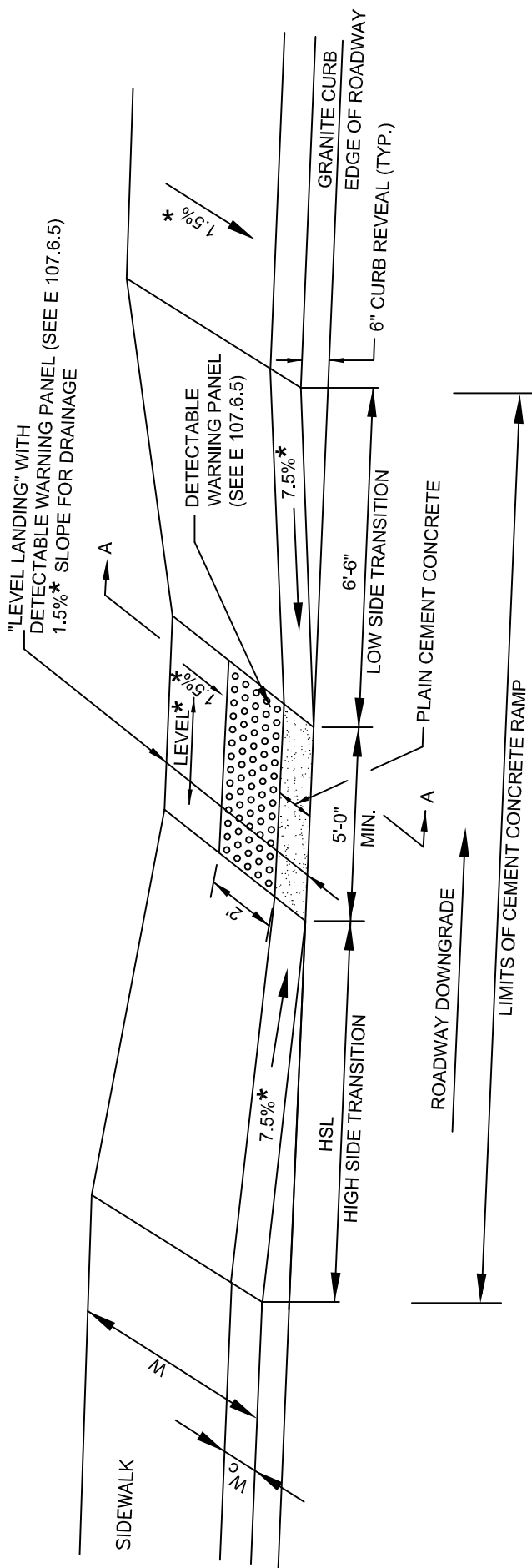

**NOTE:**  
ROADWAY, GUTTER, AND FIRST 6" OF SIDEWALK TO BE ADJUSTED FOR FIELD CONDITIONS

- LEGEND**
- HSL = HIGH SIDE TRANSITION LENGTH (SEE E 107.9.0)
  - W = SIDEWALK WIDTH
  - W<sub>C</sub> = CURB WIDTH
  - CC = CEMENT CONCRETE
  - \* = TOLERANCE FOR CONSTRUCTION ±0.5%
- USABLE SIDEWALK WIDTH PER AAB = W-W<sub>C</sub>  
 USABLE SIDEWALK WIDTH PER AAB IS NOT TO BE LESS THAN 4'0"  
 SEE E 107.6.5 FOR DETAILS OF DETECTABLE WARNING PANEL

# WHEELCHAIR RAMP ON NARROW SIDEWALK WITH DETECTABLE WARNING PANEL

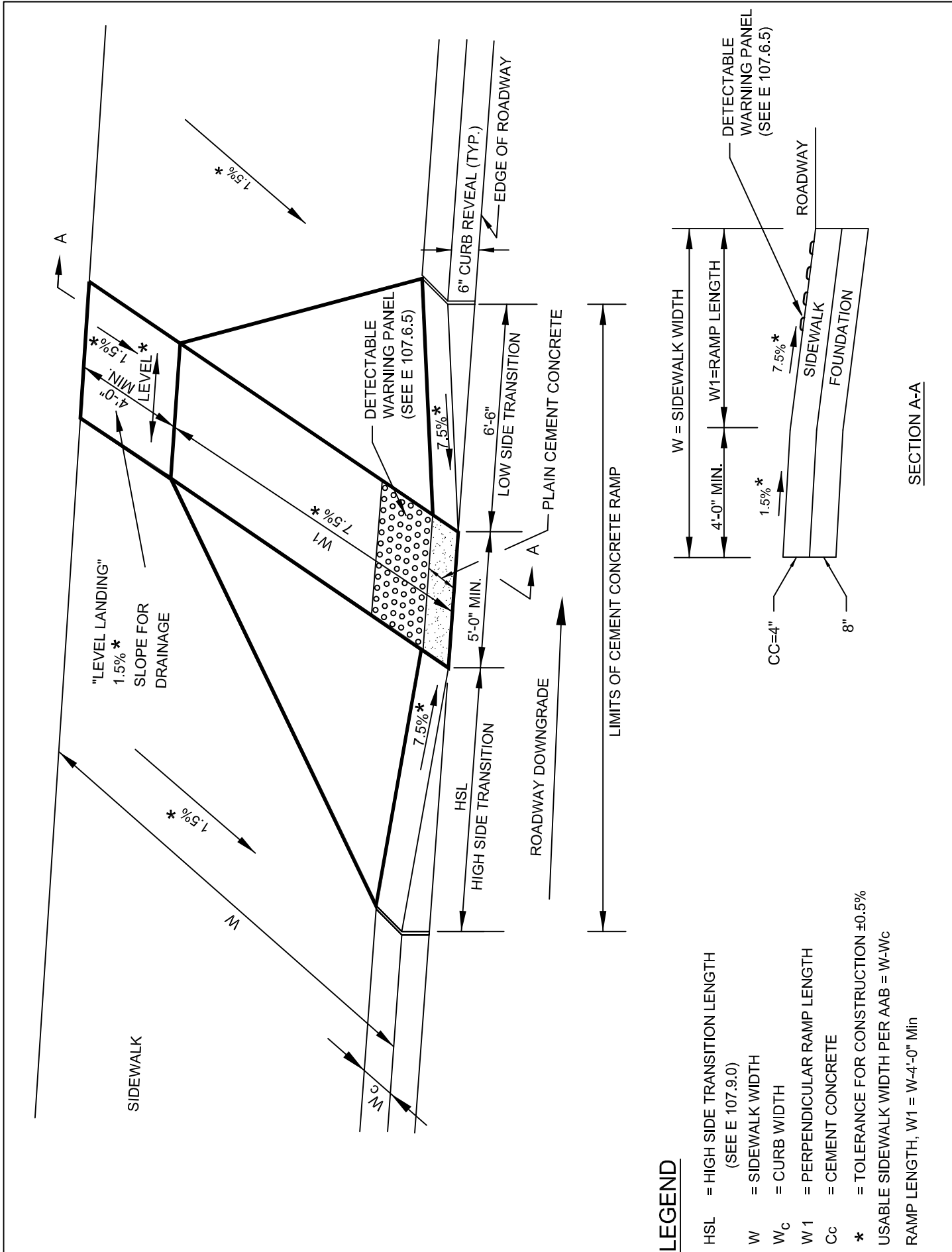

**LEGEND**

- HSL = HIGH SIDE TRANSITION LENGTH (SEE E 107.9.0)
  - W = SIDEWALK WIDTH
  - W<sub>c</sub> = CURB WIDTH
  - W1 = PERPENDICULAR RAMP LENGTH
  - Cc = CEMENT CONCRETE
  - \* = TOLERANCE FOR CONSTRUCTION ±0.5%
- USABLE SIDEWALK WIDTH PER AAB = W-W<sub>c</sub>  
 RAMP LENGTH, W1 = W-4'-0" Min

**SECTION A-A**



**WHEELCHAIR RAMPS  
 GREATER THAN 12'-4" SIDEWALK**

DATE OF ISSUE	OCTOBER 2017
DRAWING NUMBER	<b>E 107.3.0</b>

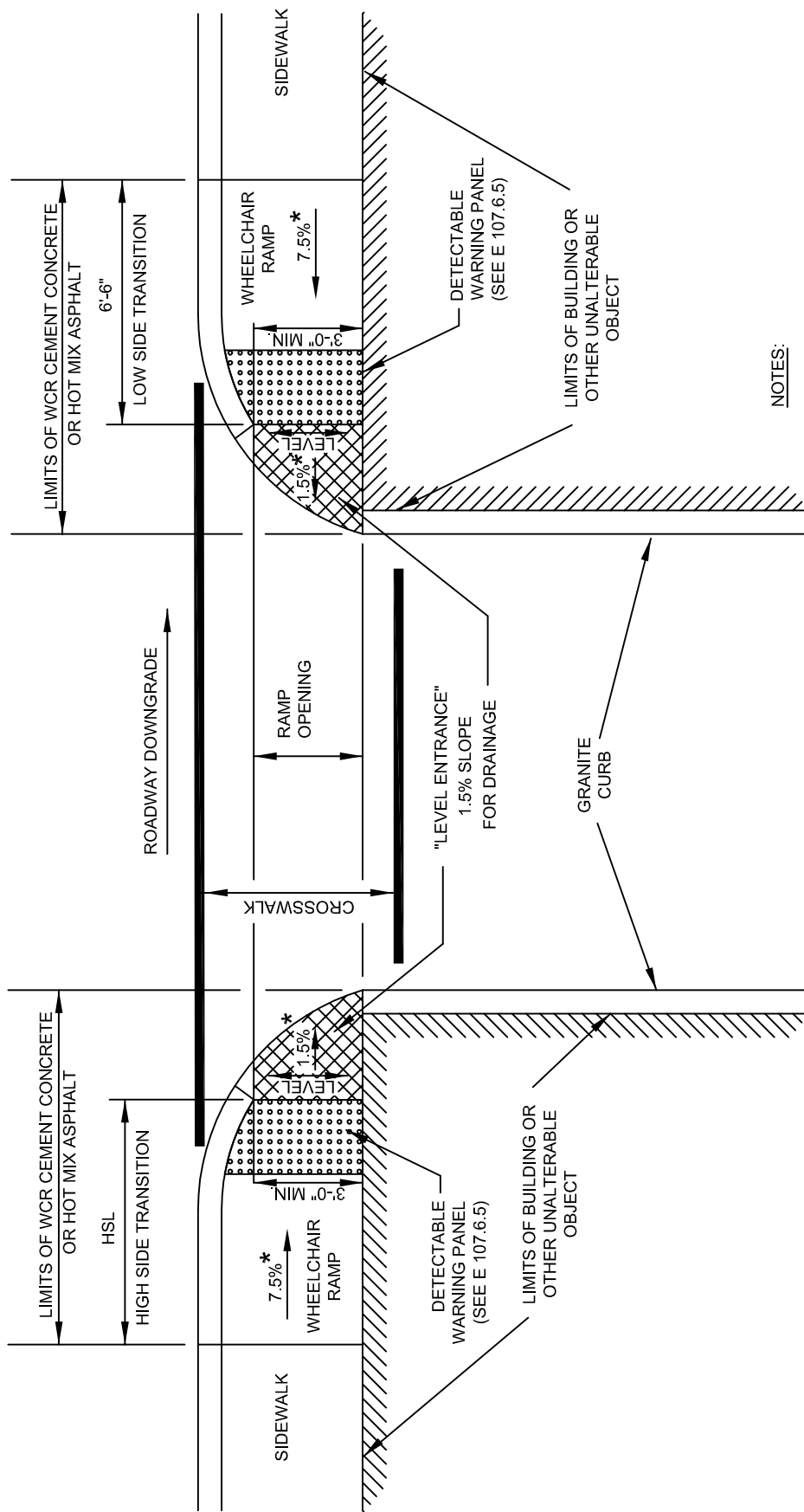

**NOTES:**

DETECTABLE WARNING PANEL  
 LOCATED NOT LESS THAN 6" OR MORE THAN 24"  
 FROM ROADWAY EDGE (GUTTER LINE). TRUNCATED  
 DOMES TO BE ALIGNED WITH DIRECTION OF TRAVEL.  
 FOR DETAILS OF TRUNCATED DOMES SEE DRAWING  
 E 107.6.5.  
 ROADWAY, GUTTER, AND FIRST 6" OF SIDEWALK TO  
 BE ADJUSTED FOR FIELD CONDITIONS.

**LEGEND**

HSL = HIGH SIDE TRANSITION LENGTH  
 (SEE E 107.9.0)  
 \* = TOLERANCE FOR CONSTRUCTION ±0.5%



# WHEELCHAIR RAMP FOR ONE CONTINUOUS DIRECTION OF PEDESTRIAN TRAVEL

DATE OF ISSUE OCTOBER 2017
DRAWING NUMBER <b>E 107.6.0</b>



# WHEELCHAIR RAMP WITH 3" CURB REVEAL

DATE OF ISSUE  
 OCTOBER 2017

DRAWING NUMBER  
**E 107.6.3**

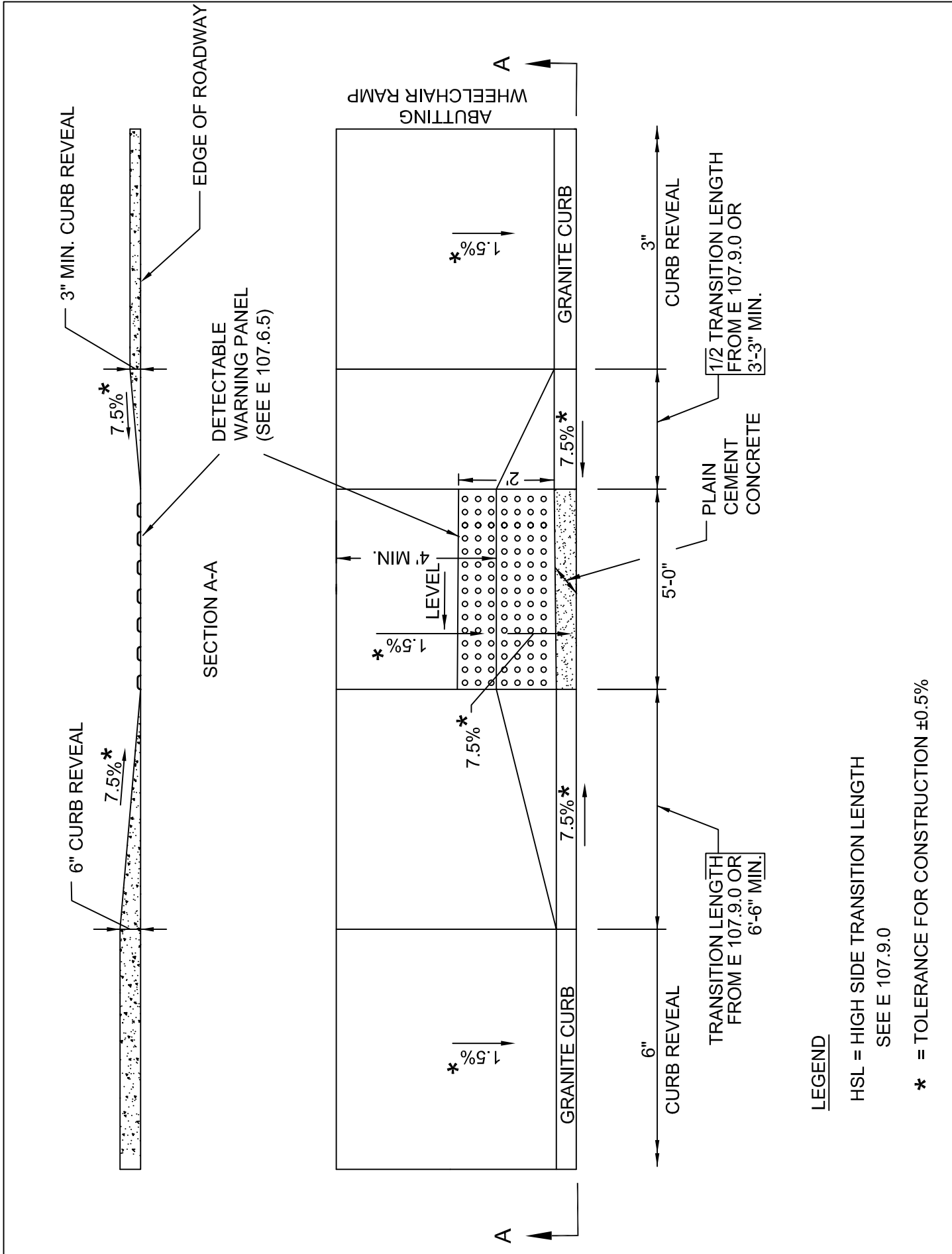

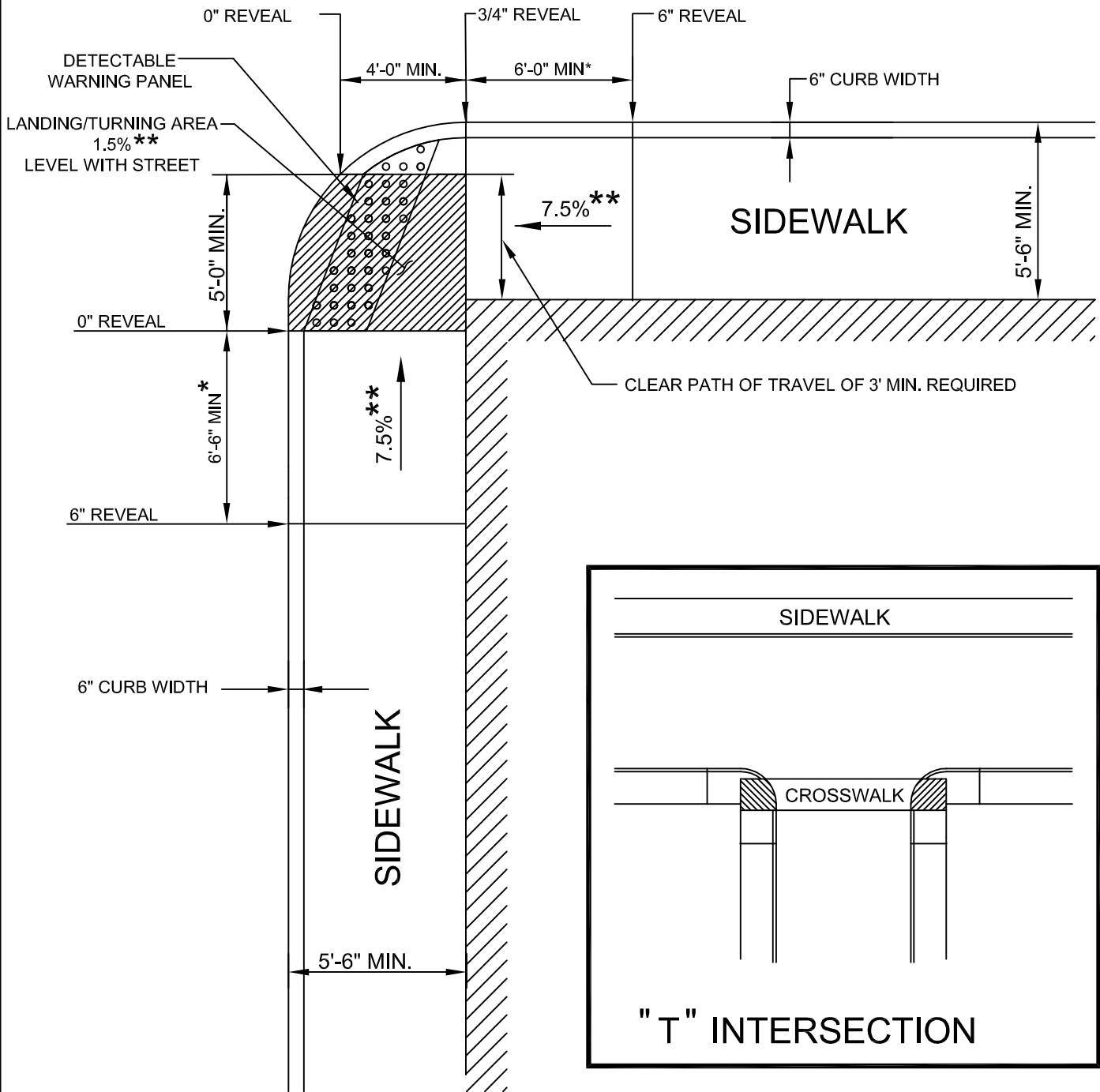

**LEGEND**



BUILDING OR OTHER UNALTERABLE CONDITION

\* TRANSITION LENGTH SHOWN IS MINIMUM.  
(SEE E 107.9.0)

\*\* TOLERANCE FOR CONSTRUCTION ±0.5%

**NOTE:**

ROADWAY, GUTTER, AND FIRST 6" OF SIDEWALK TO BE ADJUSTED FOR FIELD CONDITIONS

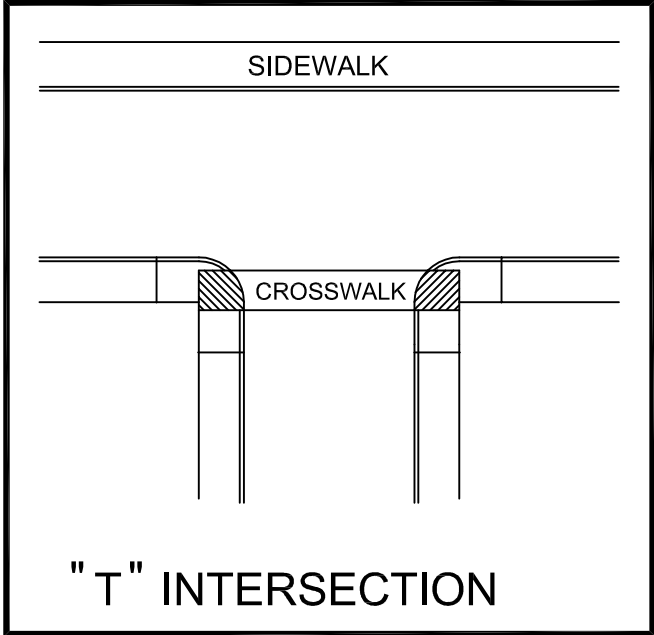

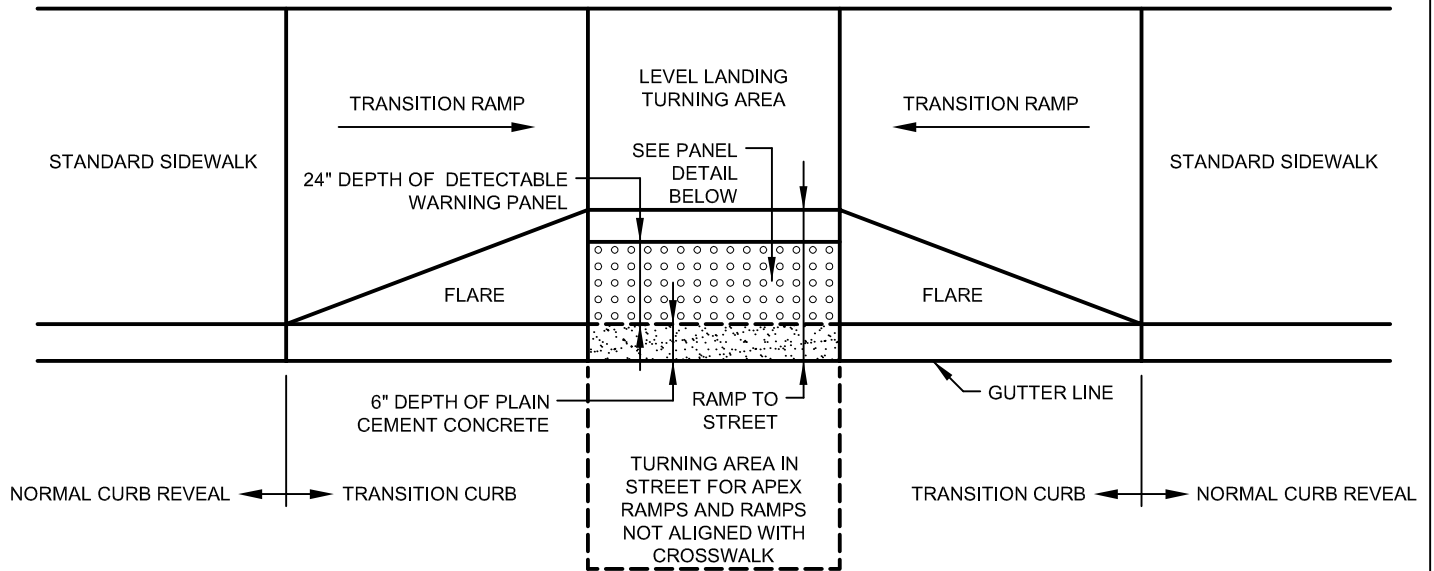

**TYPICAL INSTALLATION**

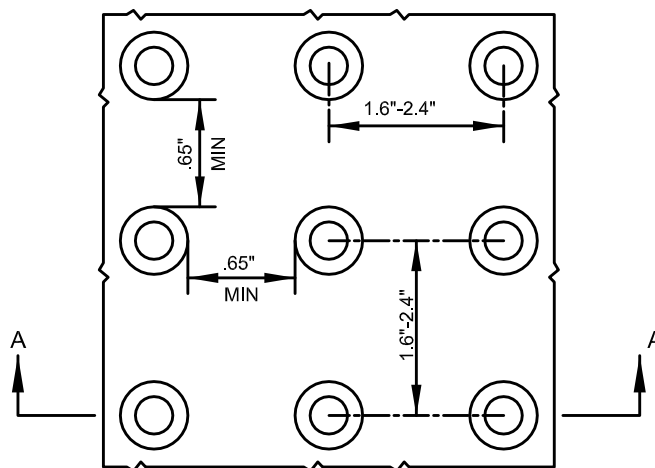

**DETAIL OF DETECTABLE WARNING PANEL**

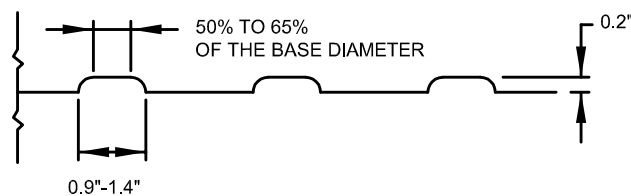

**SECTION A-A**

**NOTE:**

PANELS MAY BE CONCRETE PRECAST OR CAST IN PLACE OR OTHER SUITABLE MATERIAL PERMANENTLY APPLIED TO THE RAMP. DETECTABLE WARNING SURFACES SHALL CONTRAST VISUALLY WITH ADJACENT WALKING SURFACES EITHER LIGHT-ON-DARK, OR DARK-ON-LIGHT.

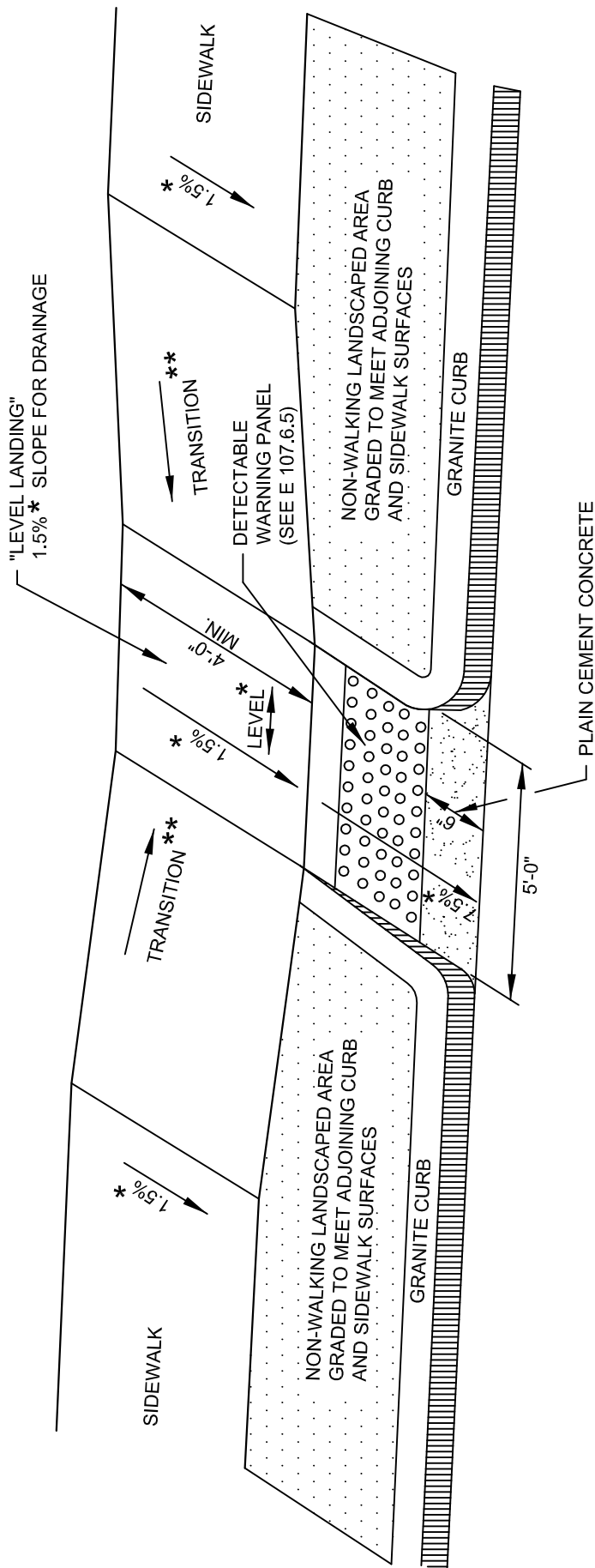

**LEGEND**

- \* = TOLERANCE FOR CONSTRUCTION ±0.5%
- \*\* = SEE E 107.9.0 FOR TRANSITION LENGTH

## CURB TRANSITION LENGTH FOR WHEELCHAIR RAMPS

ROADWAY PROFILE GRADE	* HIGH SIDE TRANSITION LENGTH
%	ENGLISH UNITS
=0%	6'-6"
>0% TO 1%	7'-8"
>1% TO 2%	9'-0"
>2% TO 3%	11'-0"
>3% TO 4%	14'-0"
>4% TO 5%	15'-0" Max

**NOTE:**

\* BASED ON A DESIGN SLOPE OF  
7.5% AND A REVEAL OF 6".

SECTION 00850

**Excerpts from Chapter 149 and Chapter 30 of the  
Massachusetts General Laws**

Certain excerpts from the Massachusetts General Laws are applicable to Construction contracts. Attention is directed to the following Sections of Chapter 149 as amended:

**Section 25.** "Every employee in public work shall lodge, board, and trade where and with whom he elects; and no person or his agents or employees under contract with the commonwealth, a county, city or town, or with a department, board, commission or officer acting therefor, for the doing of public work shall directly or indirectly require, as a condition of employment therein, that the employee shall lodge, board or trade at a particular place or with a particular person. This section shall be made a part of the contract for such employment."

**Section 26.** "In the employment of mechanics and apprentices, teamsters, chauffeurs and laborers in the construction of public works by the commonwealth, or by a county, town or district, or by persons contracting or subcontracting for such works, preference shall first be given to citizens of the commonwealth who have been residents of the commonwealth for at least six months at the commencement of their employment who are male veterans as defined in clause Forty-third of section seven of chapter four, and who are qualified to perform the work to which the employment relates; and secondly, to citizens of the commonwealth generally who have been residents of the commonwealth for at least six months at the commencement of their employment, and if they cannot be obtained in sufficient numbers, then to citizens of the United States, and every contract for such work shall contain a provisions to this effect..."

**Section 34.** "Every contract, except for the purchase of material or supplies, involving the employment of laborers workmen, mechanics, foremen or inspectors, to which the commonwealth or any county or any town, subject to section thirty, is a party, shall contain a stipulation that no laborer, workman, mechanic, foreman or inspector working within the commonwealth, in the employ of the contractor, subcontractor or other person doing or contracting to do the whole or a part of the work contemplated by the contract, shall be required or permitted to work more than eight hours in any one-day or more than forty-eight hours in any one week, or more than six-days in any one week, except in cases of emergency, or in case any town subject to section thirty-one is a party to such a contract, more than eight hours in any one-day except as aforesaid..."

**Section 34A.** "Every contract for the construction, alteration, maintenance, repair or demolition of or addition to, any public building or other public works for the commonwealth or any political subdivision thereof shall contain stipulations requiring that the contractor shall, before commencing performance of such contract, provide by insurance for the payment of compensation and the furnishing of other benefits under chapter one hundred and fifty-two to all persons to be employed under the contract, and that the contractor shall continue such insurance in full force and effect during the term of

the contract. No officer or agent contracting in behalf of the commonwealth or any political subdivision thereof shall award such a contract until he has been furnished with sufficient proof of compliance with the aforesaid stipulations. Failure to provide and continue in force such insurance as aforesaid shall be deemed a material breach of the contract and shall operate as an immediate termination thereof. No cancellation of such insurance, whether by the insurer or by the insured, shall be valid unless written notice thereof is given by the party proposing cancellation to the other party and to the officer or agent who awarded the contract at least fifteen-days prior to the intended effective date thereof, which date shall be expressed in said notice. Notice of cancellation sent by the party proposing cancellation by registered mail, postage prepaid, with a return receipt of the addressee requested, shall be a sufficient notice..."

**Section 34B.** "Every contract for the construction, alteration, maintenance, repair of demolition of, or addition to, any public works for the commonwealth or any political subdivision thereof shall contain stipulations requiring that the contractor shall pay to any reserve police officer employed by him in any city or town the prevailing rate of wage paid to regular police officers employed by him in such city or town."

Attention is directed to the following sections of Chapter 30 of the General Laws of Massachusetts as amended to date:

**Section 39F.** "(1) Every contract awarded pursuant to sections forty-four A to L inclusive, of chapter one hundred and forty-nine shall contain the following subparagraphs (a) through (i) and every contract awarded pursuant to section thirty-nine M of chapter thirty shall contain the following subparagraphs (a) through (h) and in each case those subparagraphs shall be binding between the general contractor and each subcontractor."

- "(a) Forthwith after the general contractor receives payment on account of a periodic estimate, the general contractor shall pay to each subcontractor the amount paid for the labor performed and the materials furnished by that subcontractor, less any amount specified in any court proceedings barring such payment and also less any amount claimed due from the subcontractor by the general contractor.
- "(b) Not later than the sixty-fifth-day after each subcontractor substantially completes his work in accordance with the plans and specifications, the entire balance due under the subcontract less amounts retained by the awarding authority as the estimated cost of completing the incomplete and unsatisfactory items of work, shall be due the subcontractor; and the awarding authority shall pay that amount to the general contractor. The general contractor shall forthwith pay to the subcontractor the full amount received from the awarding authority less any amount specified in any court proceedings barring such payment and also less any amount claimed due from the subcontractor by the general contractor.

- "(c) Each payment made by the awarding authority to the general contractor pursuant to subparagraphs (a) and (b) of this paragraph for the labor performed and the materials furnished by a subcontractor shall be made to the general contractor for the account of that subcontractor; and the awarding authority shall take reasonable steps to compel the general contractor to make each such payment to each such subcontractor. If the awarding authority has received a demand for direct payment from a subcontractor for any amount which has already been included in a payment to the general contractor or which is to be included in a payment to the general contractor for payment to the subcontractor as provided in subparagraphs (a) and (b), the awarding authority shall act upon the demand as provided in this section.
- "(d) If, within seventy-days after the subcontractor has substantially completed the subcontract work, the subcontractor has not received from the general contractor the balance due under the subcontract including any amount due for extra labor and materials furnished to the general contractor, less any amount retained by the awarding authority as the estimated cost of completing the incomplete and unsatisfactory items of work, the subcontractor may demand direct payment of that balance from the awarding authority. The demand shall be by a sworn statement delivered to or sent by certified mail to the awarding authority, and a copy shall be delivered or sent by certified mail to the general contractor at the same time. The demand shall contain a detailed breakdown of the balance due under the subcontract and also a statement of the status of completion of the subcontract work. Any demand made after substantial completion of the subcontract work shall be valid even if delivered or mailed prior to the seventieth-day after the subcontractor has substantially completed the subcontract work. Within ten-days after the subcontractor has delivered or so mailed the demand to the awarding authority and delivered or so mailed a copy to the general contractor, the general contractor may reply to the demand. The reply shall be by a sworn statement delivered to or sent by certified mail to the awarding authority and a copy shall be delivered to or sent by certified mail to the subcontractor at the same time. The reply shall contain a detailed breakdown of the balance due under the subcontract including any amount due for extra labor and materials furnished to the general contractor and of the amount due for each claim made by the general contractor against the subcontractor.
- "(e) Within fifteen-days after receipt of the demand by the awarding authority, but in no event prior to the seventieth-day after substantial completion of the subcontract work, the awarding authority shall make direct payment to the subcontractor of the balance due under the subcontract including any amount due for extra labor and materials furnished to the general contractor, less any amount (i) retained by the awarding authority as the estimated cost of completing the incomplete or unsatisfactory items of



work, (ii) specified in any court proceedings barring such payment, or (iii) disputed by the general contractor in the sworn reply; provided, that the awarding authority shall not deduct from a direct payment any amount as provided in part (iii) if the reply is not sworn to, or for which the sworn reply does not contain the detailed breakdown required by subparagraph (d). The awarding authority shall make further direct payments to the subcontractor forthwith after the removal of the basis for deductions from direct payments made as provided in parts (i) and (ii) of this subparagraph.

- "(f) The awarding authority shall forthwith deposit the amount deducted from a direct payment as provided in part (iii) of subparagraph (e) in an interest-bearing joint account in the names of the general contractor and the subcontractor in a bank in Massachusetts selected by the awarding authority or agreed upon by the general contractor and the subcontractor and shall notify the general contractor and the subcontractor of the date of the deposit and the bank receiving the deposit. The bank shall pay the amount in the account, including accrued interest, as provided in an agreement between the general contractor and the subcontractor or as determined by decree of a court of competent jurisdiction.
- "(g) All direct payments and all deductions from demands for direct payments deposited in an interest-bearing account or accounts in a bank pursuant to subparagraph (f) shall be made out of amounts payable to the general contractor at the time of receipt of a demand for direct payment from a subcontractor and out of amounts which later become payable to the general contractor and in the order of receipt of such demands from subcontractors. All direct payments shall discharge the obligation of the awarding authority to the general contractor to the extent of such payment.
- "(h) The awarding authority shall deduct from payments to a general contractor amounts which, together with the deposits in interest-bearing accounts pursuant to subparagraph (f), are sufficient to satisfy all unpaid balances of demands for direct payment received from subcontractors. All such amounts shall be earmarked for such direct payments, and the subcontractors shall have a right in such deductions prior to any claims against such amounts by creditors of the general contractor.
- "(i) If the subcontractor does not receive payment as provided in subparagraph (a) or if the general contractor does not submit a periodic estimate for the value of the labor or materials performed or furnished by the subcontractor and the subcontractor does not receive payment for same when due less the deductions provided for in subparagraph (a), the subcontractor may demand direct payment by following the procedure in subparagraph (d) and the general contractor may file a sworn replay as provided in that same subparagraph. A demand made after the first-day of

the month following that for which the subcontractor performed or furnished the labor and materials for which the subcontractor seeks payment shall be valid even if delivered or mailed prior to the time payment was due on a periodic estimate from the general contractor. Thereafter the awarding authority shall proceed as provided in subparagraph (e), (f), (g), and (h)."

**Section 39G.** "Upon substantial completion of the work required by a contract with the commonwealth, or any agency or political subdivision thereof, for the construction, reconstruction, alteration, remodeling, repair or improvement of public ways, including bridges and other highway structures, sewers and water mains, airports and other public works, the contractor shall present in writing to the awarding authority its certification that the work has been substantially completed. Within twenty-one-days thereafter, the awarding authority shall present to the contractor either a written declaration that the work has been substantially completed or an itemized list of incomplete or unsatisfactory work items required by the contract sufficient to demonstrate that the work has not been substantially completed. The awarding authority may include with such list a notice setting forth a reasonable time, which shall not in any even be prior to the contract completion date, within which the contractor must achieve substantial completion of the work. In the event that the awarding authority fails to respond by presentation of a written declaration or itemized list as aforesaid, to the contractor's certificate within the twenty-one-day period, the contractor's certification shall take effect as the awarding authority's declaration that the work has been substantially completed.

"Within sixty-five-days after the effective date of a declaration of substantial completion, the awarding authority shall prepare and forthwith send to the contractor for acceptance a substantial completion estimate for the quantity and price of the work done and all but one percent retainage on that work, including the quantity, price and all but one percent retainage for the undisputed part of each work item and extra work item in dispute but excluding the disputed part thereof, less the estimated cost of completing all incomplete and unsatisfactory work items and less the total periodic payments made to date for the work. The awarding authority also shall deduct from the substantial completion estimate an amount equal to the sum of all demands for direct payment filed by subcontractors and not yet paid to subcontractors or deposited in joint accounts pursuant to section thirty-nine F, but no contract subject to said section thirty-nine F shall contain any other provisions authorizing the awarding authority to deduct any amount by virtue of claims asserted against the contract by subcontractors, material suppliers or other.

"If the awarding authority fails to prepare and send to the contractor any substantial completion estimate required by this section on or before the date hereinabove set forth, the awarding authority shall pay to the contractor interest on the amount which would have been due to the contractor pursuant to such substantial completion estimate at the rate of three percentage points above the rediscount rate then charged by the Federal Reserve Bank of Boston from such date to the date on which the awarding authority sends that substantial completion estimate to the contractor for acceptance or to the date

of payment therefor, whichever occurs first. The awarding authority shall include the amount of such interest in the substantial completion estimate.

"Within fifteen-days after the effective date of the declaration of substantial completion, the awarding authority shall send to the contractor by certified mail, return receipt requested, a complete list of all incomplete or unsatisfactory work items, and, unless delayed by causes beyond his control, the contractor shall complete all such work items within forty-five-days after the receipt of such list or before the then contract completion date, whichever is later. If the contractor fails to complete such work within such time, the awarding authority may, subsequent to seven-days' written notice to the contractor by certified mail, return receipt requested, terminate the contract and complete the incomplete or unsatisfactory work items and charge the cost of same to the contractor.

"Within thirty-days after receipt by the awarding authority of a notice from the contractor stating that all of the work required by the contract has been completed, the awarding authority shall prepare and forthwith send to the contractor for acceptance a final estimate for the quantity and price of the work done and all retainage on that work less all payments made to date, unless the awarding authority's inspection shows that work items required by the contract remain incomplete or unsatisfactory, or that documentation required by the contract has not been completed. If the awarding authority fails to prepare and send to the contractor the final estimate within thirty-days after receipt of notice of completion, the awarding authority shall pay to the contractor interest on the amount which would have been due to the contractor pursuant to such final estimate at the rate hereinabove provided from the thirtieth-day after such completion until the date on which the awarding authority sends the final estimate to the contractor for acceptance or the date of payment therefor, whichever occurs first, provided that the awarding authority's inspection shows that not work items required by the contract remain incomplete or unsatisfactory. Interest shall not be paid hereunder on amounts for which interest is required to be paid in connection with the substantial completion estimate as hereinabove provided. The awarding authority shall include the amount of the interest required to be paid hereunder in the final estimate.

"The awarding authority shall pay the amount due pursuant to any periodic, substantial completion or final estimate within thirty-five-days after receipt of written acceptance for such estimate from the contractor and shall pay interest on the amount due pursuant to such estimate at the rate hereinabove provided from that thirty-fifth-day to the date of payment. In the case of periodic payment, the contracting authority may deduct from its payment a retention based on its estimate of the fair value of its claim against the contractor, a retention for direct payments to subcontractors based on demands for same in accordance with the provisions of section thirty-nine F, and a retention to secure satisfactory performance of the contractual work not exceeding five percent of the approved amount of any periodic payments, and the same right to retention shall apply to bonded subcontractors entitled to direct payment under section thirty-nine F of chapter thirty; provided that a five percent value of all items that are planted in the ground shall be deducted from the periodic payments until final acceptance.

"No periodic, substantial completion or final estimate or acceptance or payment thereof shall bar a contractor from reserving all rights to dispute the quantity and amount of, or the failure of the awarding authority to approve a quantity and amount of, all or part of any work item or extra work item.

"Substantial completion, for the purposes of this section, shall mean either that the work required by the contract has been completed except for work having a contract price of less than one percent of the then adjusted total contract price, or substantially all of the work has been completed and opened to public use except for minor incomplete or unsatisfactory work items that do not materially impair the usefulness of the work required by the contract."

**Section 39K.** "Every contract for the construction, reconstruction, alteration, remodeling, repair or demolition of any public building by the commonwealth, or by any county, city, town, district, board, commission or other public body, when the amount is more than five thousand dollars in the case of the commonwealth and more than two thousand dollars in the case of any county, city, town, district, board, commission or public body, shall contain the following paragraph: Within fifteen-days (twenty-four-days in the case of the commonwealth) after receipt from the contractor, at the place designated by the awarding authority if such a place is so designated, of a periodic estimate requesting payment of the amount due for the preceding month, the awarding authority will make a periodic payment to the contractor for the work performed during the preceding month and for the materials not incorporated in the work but delivered and suitably stored at the site (or at some location agreed upon in writing) to which the contractor has title or to which a subcontractor has title and has authorized the contractor to transfer title to the awarding authority, less (1) a retention based on its estimate of the fair value of its claims against the contractor and less (2) a retention for direct payments to subcontractors based on demands for same in accordance with the provisions of section thirty-nine F, and less (3) a retention not exceeding five percent of the approved amount of the periodic payment. After the receipt of a periodic estimate requesting final payment and within sixty-five-days after (a) the contractor fully completes the work or substantially completes the work so that the value of the work remaining to be done is, in the estimate of the awarding authority, less than one percent of the original contract price, or (b) the contractor substantially completes the work and the awarding authority takes possession for occupancy, whichever occurs first, the awarding authority shall pay the contractor the entire balance due on the contract less, (1) a retention based on its estimate of the fair value of its claims against the contractor and of the cost of completing the incomplete and unsatisfactory items of work less (2) a retention for direct payments to subcontractors based on demand for same in accordance with the provisions of section thirty-nine F, or based on the record of payments by the contractor to the subcontractors under this contract if such record of payment indicates that the contractor has not paid subcontractors as provided in section thirty-nine F. If the awarding authority fails to make payment as herein provided, there shall be added to each such payment daily interest at the rate of three percentage points above the rediscount rate then charged by the Federal Reserve Bank of Boston commencing on the first-day after said payment is due and continuing until the payment is delivered or mailed to the contractor; provided,

that no interest shall be due, in any event, on the amount due on a periodic estimate for final payment until fifteen-days (twenty-four-days in the case of the commonwealth) after receipt of such a periodic estimate from the contractor, at the place designated by the awarding authority if such a place is so designated. The contractor agrees to pay to each subcontractor a portion of any such interest paid in accordance with the amount due each subcontractor.

"The awarding authority may make changes in any periodic estimate submitted by the contractor and the payment due on said periodic estimate shall be computed in accordance with the changes so made, but such changes or any requirement for a corrected periodic estimate shall not affect the due date for the periodic payment or the date for the commencement of interest charges on the amount of the periodic payment computed in accordance with the changes made, as provided herein; provided, that the awarding authority may, within seven-days after receipt, return to the contractor for correction, any periodic estimate which is not in the required form or which contains computations not arithmetically corrected and, in that event, the date of receipt of such periodic estimate shall be the date of receipt of the corrected periodic estimate in proper form with arithmetically correct computations. The date of receipt of a periodic estimate received on a Saturday shall be the first working day thereafter. The provisions of section thirty-nine G shall not apply to any contract for the construction, reconstruction, alteration, remodeling, repair or demolition of any public building to which this section applies.

"All periodic estimates shall be submitted to the awarding authority, or to its designee as set forth in writing to the contractor, and the date of receipt by the awarding authority or its designee shall be marked on the estimate. All periodic estimates shall contain a separate item for each filed subtrade and each subtrade listed in sub-bid form as required by specifications and a column listing the amount paid to each filed subcontractor and Sub-subcontractor as of the date the periodic estimate is filed. The person making payment for the awarding authority shall add the daily interest provided for herein to each payment for each day beyond the due date based on the date of receipt marked on the estimate.

"A certificate of the architect to the effect that the contractor has fully or substantially completed the work shall, subject to the provisions of section thirty-nine J, be conclusive for the purposes of this section."

**Section 39L.** "Public Construction work by foreign corporations; restrictions and reports." The Commonwealth and every county, city, town, district, board, commission or other public body which, as the awarding authority, request proposals, bids or sub-bids for any work in the construction, reconstruction, alteration, remodeling, repair or demolition of any public building or other public works (1) shall not enter into a contract for such work with, and shall not approve as a subcontractor furnishing labor and materials for a part of any such work, a foreign corporation which has not filed with such awarding authority a certificate of the state secretary stating that such corporation has complied with sections three and five of chapter one hundred and eighty-one and the date

of such compliance, and (2) shall report to the state secretary and to the department of corporations and taxation any foreign corporation performing work under such contract or subcontract, and any person, other than a corporation, performing work under such contract or subcontract, and residing or having a principal place of business outside the commonwealth.

**Section 39M(b).** "Specifications for such contracts, and specifications for contracts awarded pursuant to the provisions of said sections forty-four A to forty-four L of said chapter one hundred and forty-nine, shall be written to provide for full competition for each item of material to be furnished under the contract; except, however, that said specifications may be otherwise written for sound reasons in the public interest stated in writing in the public records of the awarding authority or promptly given in writing by the awarding authority to anyone making a written request therefor, in either instance such writing to be prepared after reasonable investigation. Every such contract shall provide that an item equal to that named or described in the said specifications may be furnished; and an item shall be considered equal to the item so named or described if (1) it is at least equal in quality, durability, appearance, strength and design, (2) it will perform at least equally the function imposed by the general design for or the public work being contracted for or the material being purchased, and (3) it conforms substantially, even with deviations, to the detailed requirements for the item in the said specifications.

"For each item of material the specifications shall provide for either a minimum of three named brands of material or a description of material which can be met by a minimum of three manufacturers or producers, and for the equal of any one of said named or described materials."

**Section 39N.** "Every contract subject to section forty-four A of Chapter one hundred and forty-nine or subject to section thirty-nine M of chapter thirty shall contain the following paragraph in its entirety and an awarding authority may adopt reasonable rules or regulations in conformity with that paragraph concerning the filing, investigation and settlement of such claims:

"If, during the progress of the work, the contractor or the awarding authority discovers that the actual subsurface or latent physical conditions encountered at the site differ substantially or materially from those shown on the plans or indicated in the contract documents either the contractor or the contracting authority may request an equitable adjustment in the contract price of the contract applying to work affected by the differing site conditions. A request for such an adjustment shall be in writing and shall be delivered by the party making such claim to the other party as soon as possible after such conditions are discovered. Upon receipt of such a claim from a contractor, or upon its own initiative, the contracting authority shall make an investigation of such physical conditions, and, if they differ substantially or materially from those shown on the plans or indicated in the contract documents or from those ordinarily encountered and generally recognized as inherent in work of the character provided for in the plans and contract documents and are of such a nature as to cause an increase or decrease in the cost of performance of the work or a change in the construction methods required for the

performance of the work which results in an increase or decrease in the cost of the work, the contracting authority shall make an equitable adjustment in the contract price and the contract shall be modified in writing accordingly."

**Section 39O.** "Every contract subject to the provisions of section thirty-nine M of this chapter or subject to section forty-four A of chapter one hundred forty-nine shall contain the following provisions (a) and (b) in their entirety....

"(a) The awarding authority may order the general contractor in writing to suspend, delay, or interrupt all or any part of the work for such period of time as it may determine to be appropriate for the convenience of the awarding authority; provided however, that if there is a suspension, delay or interruption for fifteen-days or more due to a failure of the awarding authority to act within the time specified in this contract, the awarding authority shall make an adjustment in the contract price for any increase in the cost of performance of this contract but shall not include any profit to the general contractor on such increase; and provided further, that the awarding authority shall not make any adjustment in the contract price under this provision for any suspension, delay, interruption or failure to act to the extent that such is due to any cause for which this contract provides for an equitable adjustment of the contract price under any other contract provisions.

"(b) The general contractor must submit the amount of a claim under provision (a) to the awarding authority in writing as soon as practicable after the end of the suspension, delay, interruption or failure to act and, in any event, not later than the date of final payment under this contract and, except for costs due to a suspension order, the awarding authority shall not approve any costs in the claim incurred more than twenty-days before the general contractor notified the awarding authority in writing of the act or failure to act involved in the claim.

**Section 39P.** "Every contract subject to section thirty-nine M of this chapter or section forty-four A of chapter one hundred forty-nine which requires the awarding authority, or any official, its architect or engineer to make a decision on interpretation of the specifications, approval of equipment, material or any other approval, or progress of the work, shall require that the decision be made promptly and, in any event, no later than thirty-days after the written submission for decision; but if such decision requires extended investigation and study, the awarding authority, the official, architect or engineer shall, within thirty-days after the receipt of the submission, give the party making the submission written notice of the reasons why the decision cannot be made within the thirty-day period and the date by which the decision will be made."

**Section 39R(a).** "The words defined herein shall have the meaning stated below whenever they appear in this section:

- (1) "Contractor" means any person, corporation, partnership, joint venture, sole proprietorship, or other entity awarded a contract pursuant to section thirty-nine M of chapter thirty, sections forty-four A through H, inclusive, of chapter one hundred and forty-nine and sections thirty B through thirty P, inclusive, of chapter seven.
- (2) "Contract" means any contract awarded or executed pursuant to sections thirty B through thirty P, inclusive, of chapter seven and any contract awarded or executed pursuant to section thirty-nine M of chapter thirty, or sections forty-four A through H, inclusive, of chapter one hundred and forty-nine, which is for an amount or estimated amount greater than one hundred thousand dollars.
- (3) "Records" means books of original entry, accounts, checks, bank statements and all other banking documents, correspondence, memoranda, invoices, computer printouts, tapes, discs, papers and other documents or transcribed information of any type, whether expressed in ordinary or machine language.
- (4) "Independent Certified Public Accountant" means a person duly registered in good standing and entitled to practice as a certified public accountant under the laws of the place of his/her residence or principal office and who is in fact independent. In determining whether an accountant is independent with respect to a particular person, appropriate consideration should be given to all relationships between the accountant and that person or any affiliate thereof. Determination of an accountant's independence shall not be confined to the relationships existing in connection with the filing of reports with the awarding authority.
- (5) "Audit," when used in regard to financial statements, means an examination of records by an independent certified public accountant in accordance with generally accepted accounting principles and auditing standards for the purpose of expressing a certified opinion thereon, or, in the alternative, a qualified opinion or a declination to express an opinion for stated reasons.
- (6) "Accountant's Report," when used in regard to financial statements, means a document in which an independent certified public accountant indicates the scope of the audit which he/she has made and sets forth his/her opinion regarding the financial statements taken as a whole with a listing of noted exceptions and qualifications, or an assertion to the effect that an overall opinion cannot be expressed. When an overall opinion cannot be expressed the reason therefor shall be stated. An accountant's report shall include as a part thereof a signed statement by the responsible corporate officer attesting that management has fully disclosed all material facts to the independent certified public accountant, and that the audited financial



statement is a true and complete statement of the financial condition of the contractor.

- (7) "Management," when used herein, means the chief executive officer, partners, principals or other person or persons primarily responsible for the financial and operational policies and practices of the contractor.
- (8) Accounting terms, unless otherwise defined herein, shall have a meaning in accordance with generally accepted accounting principles and auditing standards.
  - (b) Subsection (a)(2) hereof notwithstanding, every agreement or contract awarded or executed pursuant to sections thirty B through thirty P, inclusive, of chapter seven, and pursuant to section thirty-nine M of chapter thirty or to section forth-five A through H, inclusive, of chapter one hundred and forty-nine, shall provide that:
    - (1) The contractor shall make, and keep for at least six years after final payment, books, records, and accounts which in reasonable detail accurately and fairly reflect the transactions and dispositions of the contractor, and
    - (2) Until the expiration of six years after final payment, the awarding authority, office of inspector general, and the deputy commissioner of capital planning and operations shall have the right to examine any books, documents, papers or records of the contractor or of his/her subcontractors that directly pertain to, and involve transactions relating to, the contractor or his/her subcontractors, and
    - (3) If the agreement is a contract as defined herein, the contractor shall describe any change in the method of maintaining records or recording transactions which materially affect any statements filed with the awarding authority, including in his/her description the date of the change and reasons therefor, and shall accompany said descriptions with a letter from the contractor's independent certified public accountant approving or otherwise commenting on the changes, and
    - (4) If the agreement is a contract as defined herein, the contractor has filed a statement of management on internal accounting controls as set forth in paragraph (c) below prior to the execution of the contract, and
    - (5) If the agreement is a contract as defined herein, the contractor has field prior to the execution of the contracts and will continue to file annually, an audited financial statement for the most recent completed fiscal year as set forth in paragraph (d) below.

(c) Every contractor awarded a contract shall file with the awarding authority a statement of management as to whether the system of internal accounting controls of the contractor and subsidiaries reasonably assures that:

- (1) Transactions are executed in accordance with management's general and specific authorization;
- (2) Transactions are recorded as necessary:
  - i. To permit preparation of financial statements in conformity with generally accepted accounting principles, and
  - ii. To maintain accountability for assets;
- (3) Access to assets is permitted only in accordance with management's general or specific authorization; and
- (4) The recorded accountability for assets is compared with the existing assets at reasonable intervals and appropriate action was taken with respect to any difference.

Every contractor awarded a contract shall also file with the awarding authority a statement prepared and signed by an independent certified public accountant, stating that he/she has examined the statement of management on internal accounting controls, and expressing an opinion as to:

- (1) Whether the representations of management in response to this paragraph, and paragraph (b) above are consistent with the result of management's evaluation of the system of internal accounting controls; and
  - (2) Whether such representations of management are, in addition, reasonable with respect to transactions and assets in amounts which would be material when measured in relation to the applicant's financial statements.
- (d) Every contractor awarded a contract by the commonwealth or by any political subdivision thereof shall annually file with the awarding authority and the deputy commissioner of capital planning and operations during the term of the contract a financial statement prepared by an independent certified public accountant on the basis of an audit by such accountant. The final statement filed shall include the date of final payment. All statements shall be accompanied by an accountant's report. Such statements shall be made available to the awarding authority upon request.

- (e) The office of inspector general, the deputy commissioner for capital planning and operations and any other awarding authority shall enforce the provisions of this section. The deputy commissioner of capital planning and operations may after providing an opportunity for the inspector general and other interested parties to comment, promulgate pursuant to the provisions of chapter thirty A such rules, regulations and guidelines as are necessary to effectuate the purposes of this section. Such rules, regulations and guidelines may be applicable to all awarding authorities. A contractor's failure to satisfy any of the requirements of this section may be grounds for debarment pursuant to section forty-four C of chapter one hundred and forty-nine."
- (f) Records and statements required to be made, kept or filed under the provisions of this section shall not be public records as defined in section seven of chapter four and shall not be open to public inspection; provided, however, that such records and statements shall be made available pursuant to the provisions of clause (2) of paragraph (b).

**Section 40.** "Bonds give to the commonwealth, any county, city, town or political subdivision to secure the performance of contracts for the construction or repair of public buildings or other public works may be discharged or released by the awarding authority, upon such terms as it deems expedient, after the expiration of one year from the time of completion, subject to section thirty-nine K, of the work contracted to be done; provided that no claim filed under said bond is pending, and provided further, that no such bonds shall be discharged or released prior to the expiration of all special guarantees provided for in the contract unless new bonds in substitution therefor specifically relating to the unexpired guarantees shall be taken.

#### EQUAL EMPLOYMENT OPPORTUNITIES

The Contractor and each Subcontractor shall comply with the provisions of the Governor's "Executive Order No. 74", dated July 20, 1970, entitled the "Governor's Code of Fair Practices", as amended by the Governor's "Executive Order No. 116", dated May 1, 1975; with the Fair Employment Practices Law of Massachusetts, as amended; with the Rules and Regulations of the Massachusetts Commission Against Discrimination, as in force at the date hereof; and with all other applicable municipal, state and federal laws and regulation regarding equal employment opportunity.



## SECTION 01015

### SPECIAL REQUIREMENTS

Supplementing Massachusetts Highway Department  
Standard Specifications  
Construction Details

#### SCOPE OF WORK

The estimate total value of this contract is projected to be \$3,813,513.45 depending on available funding. Quantities are indeterminate and are provided only for the purpose of comparing bids. The Town of Dedham reserves the right to increase or decrease the estimated total value of this contract without any changes in the Contractor's unit bid prices.

Work will be at various locations all over Town as directed by the Director of Public Works. The Work consists of various forms of asphalt paving and resurfacing including but not limited to full depth reclaiming, grading and compaction, milling, paving, installation of bituminous and granite curbing, and installation and repair of bituminous and concrete sidewalks, and other miscellaneous work including the excavation and replacement of unsuitable materials as directed by the Director of Public Works or his designee. The Director prior to the commencement of the work will mark the limits and locations of work in the field.

All items of work in this contract shall be in conformance with the "Commonwealth of Massachusetts, Highway Department (MHD) Standard Specifications for Highway and Bridges", dated 2021, including the latest supplements and addendum thereto; the 2017 Construction Standard Details; the Dedham DPW Design & Construction Standards, the 2009 Manual on Uniform Traffic Control Devices and addendum thereto; the 1990 Standard Drawings for Signs and Supports; the 1968 Standard Drawings for Traffic Signals and Highway Lighting; the American Standards for Nursery Stock (ANSI Z 60.1 - 1986); and these Special Provisions.

#### CONFLICTS BETWEEN SPECIFICATIONS

Wherever a conflict exists between the Special Provisions, Plans, Supplemental Specifications, or Standard Specifications, the conflict shall be resolved in the accordance with Subsection 5.04, Division I, of the Massachusetts Highway Department Standard Specifications.

#### CONTRACT REQUIREMENTS & DEFINITIONS

The words "municipal" or "municipality" in this document shall mean the Town of Dedham.

The Standard Specifications, where referred to, shall mean the "Commonwealth of Massachusetts Highway Department (MHD) Standard Specifications for Highways and Bridges", dated 2020, including the latest supplements and addendum thereto. All work items to be performed refer to the Standard Specifications items unless otherwise indicated.

The materials are subject to inspection prior to the awarding of a Contract. All materials shall meet or exceed the requirements as written in the Standard Specifications.

No contract award will be deemed to be legally made until a completed and signed contract is executed. The Contractor shall comply with all state and local laws, ordinances and regulations governing the type of work called for in these specifications, particularly in reference to safety and fire regulations.

The Town of Dedham shall be responsible for providing a work site that is swept clean and ready for the Contractor to perform all work. The Contractor is responsible for leaving the work site in a similar manner.

The Contractor must have a supervisor or foreman available at all times to direct operations. This supervisor or foreman will report to the Town any problems as well as give progress reports.

The Contractor must show by past performance that he is capable of performing a contract of this magnitude and must enclose a list of other contracts he has completed in other cities and towns.

The Contractor agrees not to sublet or assign the Contract in whole or in part without the written approval or the written authorization of the Town. However, nothing contained in this agreement shall create any contractual relationship between a subcontractor and the Town.

#### SCHEDULE AND SAFETY MEASURES FOR CONSTRUCTION IMPACTS

Work, unless otherwise noted, is restricted to a ten-hour window, five-day week, with the Prime Contractor and all subcontractors working on the same shift. The daily work shift shall begin no sooner than 7:00 A.M. and shall end no later than 5:00 P.M.

No work shall be performed on Saturdays, Sundays, or Holidays without the expressed written approval of the Town and the concurrence of the Chief of Police, except in the situation of On-Call Emergency Services. Such approval shall be requested one week in advance of the date upon which the Contractor wishes to perform work.

The Contract period shall extend to December 31, 2022. All prices submitted by the Contractor shall be fixed for the entire Contract period.

The Contractor shall perform the work to a schedule prepared by the Contractor and approved by the Town. All work shall be scheduled only at times acceptable to the Town. The Contractor shall indicate the amount of time required to perform the work and present a tentative schedule to complete such work (weather permitting).

The Contractor shall schedule the work in a manner that facilitates the completion of work at one location while starting the work at another. Excavation shall be limited to those areas that the Contractor can finish in a reasonable amount of time.

At the end of each workday, all safety control devices shall be in place so that traffic flow can resume and safety is enhanced. It is the Contractor's responsibility to provide all appropriate warning signs, reflectorized drums, flashers, and other safety control devices necessary. Street closures, lane closures, partial lane closures, and detours are all considered part of the traffic management measures required under the Contract.

All traffic management measures shall be implemented in accordance with the drawings and these Special Provisions, and as directed by the Town. The Contractor shall also provide dust control measures using either calcium chloride or water. When directed by the Town, the Contractor shall pave work areas with a bituminous concrete patch to provide for enhanced traffic flow and safety.

Any detours proposed by the contractor must be submitted to the Town, Police and Fire Department of the Town of Dedham at least 72 hours prior to the implementation of the detour. The contractor must receive written approval of the detour prior to the commencement of the scheduled work. Each submitted detour plan shall conform to the relevant section of Part VI of the Manual for Uniform Traffic Control Devices (MUTCD)

#### QUALIFICATION

The Contractor shall be responsible for payment of prevailing wages for work performed as determined by the Director of Labor and Industries under the provisions of the Massachusetts General Laws, Chapter 149, Sections 26 to 27D.

#### INSPECTION

One or more inspectors may be assigned by the Town to oversee construction of the work, and shall have the authority to monitor the work. All official orders or directives, which increase the cost of the project, shall be approved by the Town. All extra work orders will require written approval by the Town before performing the work. All costs associated with inspection shall be borne by the Town.

#### WORK BY OTHERS AND COOPERATION BY THE CONTRACTOR

(Supplementing Subsections 5.05 and 5.06 of the Standard Specifications)

Agents of various Public Service Agencies, Municipal and State Departments may be entering on the work site to remove existing facilities, to construct or place new facilities or to make alterations to existing facilities.

The Contractor shall perform the work in cooperation with the various agencies in a manner, which causes the least interference with the operations of the aforementioned agencies and shall have no claim for delay, which may be due, or result, from said work of these agents.

The Contractor shall be fully responsible for arranging and coordinating his work that is to be performed by others. This coordination and phasing shall be submitted to the Town for his

approval.

Work required on all private utilities made necessary by the construction of this project will be accomplished by the respective utility companies. Each utility company shall be responsible for their own safety control including detail officers if required

#### PUBLIC SAFETY AND CONVENIENCE

(Supplementing Subsection 7.09 of the Standard Specifications)

The Contractor's attention is directed to the fact that work on this project is to be performed on streets, which are utilized by pedestrians as well as by vehicles. The Contractor shall be responsible for the installation of adequate precautions and other safety measures and controls deemed necessary by the Town for the Contractor's own personnel. Any automotive equipment not protected by traffic cones or plastic drums that is working on a public way under this project shall have one amber flashing warning light mounted on the cab roof or in the highest practical point of the machinery. This light shall be in operation while the equipment is so working.

The Contractor shall be required, without additional compensation to provide safe and convenient access to all abutters during the prosecution of the work. Necessary access for fire apparatus and other emergency vehicles shall be maintained at all times. Sweeping and cleaning of surfaces beyond the limits of the project to clean up material caused by spillage or vehicular tracking during the various phases of the work shall be considered as incidental to the work being performed under the Contract and there will be no additional compensation.

#### CLEANING UP

During its progress, the work and the adjacent areas affected thereby shall be kept cleaned and all rubbish, surplus materials, and unneeded construction equipment shall be removed and all damage repaired so that the public and property owners will be inconvenienced as little as possible.

Where material or debris has washed or flowed into or been placed in existing watercourses, ditches, gutters, drains, pipes structures, or elsewhere during the course of the Contractor's operations, such material or debris shall be entirely removed and satisfactorily disposed of during the progress of the work, and the ditches, channels, drains, pipes, structures, etc., shall, upon completion of the work, be left in a clean and neat condition.

On or before the completion of the work, the Contractor shall, unless otherwise especially directed or permitted in writing, tear down and remove all temporary buildings and structures built by him; shall remove all temporary works, tools, and machinery or other construction equipment furnished by him; shall remove, acceptably disinfect, and cover all organic matter and material containing organic matter in, under, and around privies, houses, and other buildings used by him; shall remove all rubbish from any grounds which he has occupied; and shall leave the roads and all parts of the premises and adjacent property affected by his operations in a neat and satisfactory condition.



The Contractor shall restore or replace, when and as directed by the Town, any public or private property damaged by his work, equipment, or employees, to a condition at least equal to that existing immediately prior to the beginning of operations. To this end the Contractor shall do as required all necessary highway or driveway, walk, and landscaping work.

Suitable materials, equipment, and methods shall be used for such restoration. The restoration of existing property or structures shall be done as promptly as practicable as work progresses and shall not be left until the end of the Contract period.

PROVISIONS FOR ACCESS AT ALL LOCATIONS

(Supplementing Section 5.09 of the Standard Specifications)

The Contractor shall cooperate with the various utility companies, public agencies and the municipality, and provide access through the site if required for their work or to observe work in connection with this project that affects their respective properties, but all official orders and directives to the Contractor will be issued by the Town or its duly appointed representative.

NOTICE TO OWNERS OF UTILITIES

(Supplementing Subsection 7.13 of the Standard Specifications)

Written notice shall be given by the Contractor to all public service corporations or municipal and State officials owning or having charge of publicly or privately owned utilities of his intention to commence operations affecting such utilities at least one week in advance of the commencement of such operations. The Contractor shall, at the same time, file a copy of such notice with the Town.

Before commencing work on service connections, the Contractor shall be responsible for contacting the Electric Company serving the area to obtain construction requirements, standards, and to give adequate notice of commencement of work. The Contractor's attention is further directed to the requirements of "Work in the Immediate Vicinity of Certain Underground Structures and Utility Poles" herein included in these Special Provisions.

The following are the names of owners of the principal utilities affected, but the Town does not guarantee completeness of this list.

Town of Dedham  
Department of Public Works  
55 River Street  
Dedham, MA 02026  
Telephone: (781) 751-9350

COMCAST  
55 Concord Street  
N. Reading, MA 01864  
(978) 207-2351

Dedham Police Department  
600 High Street  
Dedham, MA 02026  
Telephone: (781) 320-8757

Dedham Fire Department  
436 Washington Street  
Dedham, MA 02026  
Telephone: (781) 326-9300

Eversource Electric  
247 Station Drive  
Westwood, MA 02090  
Telephone: (781) 441-8925

Eversource Gas  
247 Station Drive  
Westwood, MA 02090  
Telephone: (781) 441-8937

RCN  
201 University Avenue  
Westwood, MA 02090  
(781) 381-3007

Verizon  
125 Lundquist Drive  
Braintree, MA 02148  
Telephone: (781) 849-6366

Dedham-Westwood Water District  
50 Elm Street  
Dedham, MA 02026  
Telephone: (781) 329-7090

MWRA  
100 First Avenue  
Boston, MA 02129  
(617) 242-6000

## PROTECTION OF UNDERGROUND FACILITIES

Before the Contractor begins any work or operations, which might damage any subsurface structures, he shall carefully locate all such structures and conduct his operations so as to avoid any damage to them.

The Contractor shall make his own investigation to assure that no damage to existing structures, drainage lines, traffic signal conduits, and other utilities will occur as a result of his operations.

The Contractor shall notify "DIG SAFE", 72 hours in advance of any digging, and procure a DIG SAFE number of each location prior to disturbing ground in any way.

"DIG SAFE" Call Center: Telephone 1-888-344-7233

## PROTECTION OF UTILITIES AND PROPERTY

(Supplementing Subsection 7.13 of the Standard Specifications)

The Contractor, in constructing or installing facilities alongside or near sanitary sewers, storm drains, water or gas pipes, electric or telephone conduits, poles, sidewalks, walls, vaults, or other structures shall, at his expense, sustain them securely in place, cooperating with the officers and agents of the various utility companies and municipal departments which control them, so that the services of these structures shall be maintained. The Contractor shall also be responsible for the repair or replacement, at his own expense, of any damage to such structure caused by his acts or neglect, and shall leave them in the same condition as they existed prior to commencement of the work.

In case of damage to utilities, the Contractor shall promptly notify the utility owner and shall, if requested by the Town, furnish labor and equipment to work temporarily under the owner's direction in providing access to the utility. Pipes or other structures damaged by the operation of the Contractor may be repaired by the Town or by the utility owner, which suffers the loss. The cost of such repairs shall be borne by the Contractor, without compensation therefore.

If, as the work progresses, it is found that any of the utility structures are so placed as to render it impracticable, in the judgment of the Town, to do the work called for under the contract, the Contractor shall protect and maintain the services in such utilities and structures and the Town will, as soon thereafter as reasonable, cause the position of the utilities to be changed or take such other actions deemed suitable and proper.

If live service connections are to be interrupted by excavations of any kind, the Contractor shall not break the service until new services are provided. Abandoned services shall be plugged off or otherwise made secure. Operation of all existing water system valves shall be by the Dedham-Westwood Water District or as authorized by the same.

Full compensation for furnishing all labor, materials, tools, equipment and incidentals for doing all the work involved in protecting or repairing property as specified in this section, shall be

included in the lump sum price and no additional compensation will be allowed therefore.

WORK IN THE IMMEDIATE VICINITY OF CERTAIN  
UNDERGROUND STRUCTURES AND UTILITY POLES

For overhead connections, EVERSOURCE Electric will make the connection from the top of the riser on the utility pole to the power source. The Contractor shall supply all labor, materials and equipment to install the service connection, complete in place and in accordance with EVERSOURCE Electric procedures, from the controller to and including the riser with enough wire coiled above the rise to permit EVERSOURCE Electric to make the final connection.

For underground connections, EVERSOURCE Electric will perform the actual wiring of the service connections from its power source to the sweep at the local controllers but all steel sweeps duct, entrance holes into manholes, patching and all other necessary labor, materials and equipment required to install the electric service, complete in place, shall be furnished by the Contractor.

The Contractor shall pay EVERSOURCE Electric for their services rendered for the connection of overhead and underground service connections.

No work is to be performed in the immediate vicinity of EVERSOURCE Electric manholes or utility poles, or VERIZON manholes or utility poles or conduit system without prior notice (at last 48 hours) to the affected company.

Before starting work at existing manholes, the Contractor shall test for gas and blow out the manholes.

PROVISIONS FOR TRAVEL AND PROSECUTION OF THE WORK  
(Supplementing Subsection 8.02 and 8.03 of the Standard Specifications)

Before starting any work under the contract, the Contractor shall submit a Schedule of Operations as provided in Section 8.02. The work schedule shall include a plan of his construction procedures and the safety measures he will use during the prosecution of the work as set forth in Section 850 of the Standard Specifications for Highways and Bridges. This plan shall indicate the temporary barricades, signs, drums, and other traffic control devices to be employed during the period of work to maintain traffic and pedestrian safety. Said plan shall conform to Part VI of the 2009 edition of the MUTCD.

Particular care should be taken to establish and maintain methods and procedures, which will not create unnecessary or unusual hazards to public safety. As necessary and/or as directed by the Town, uniformed traffic police shall be employed for the protection and maintenance of traffic. Reasonable facilities shall be provided by the Contractor for the convenient, safe passage of pedestrians and vehicles through the project, and also to and from properties abutting the site of improvement.

Particular care shall be exercised at all times to establish and maintain such methods of work on

any roadway which would interfere with the existing flow of traffic shall be limited to approximately one-half width at any one time. At least one lane in each direction shall be kept open at all times. No detouring of traffic shall be allowed without permission of the Town and the Dedham Police Department.

The Contractor shall give notice in writing to the Town at least seven days in advance of beginning any work affecting the maintenance of traffic where work affects the streets in use by the public. The Contractor must prosecute the work efficiently and with the least possible delay. The Contractor, as shown on the Contract Drawings and as directed by the Town, is responsible for furnishing, erecting, and maintaining the temporary signing of the roadways, and the proper removal of the signs upon the completion of the project. Construction work on the project shall not commence until the construction signing and traffic barriers as described in the Contract Drawings have been installed and approved.

Traffic Control devices required only during working hour operations shall be removed at the end of each working day.

Signs having messages that are irrelevant to normal traffic conditions shall be removed or properly covered at the end of each work period. Signs shall be kept clean at all times and legends shall be distinctive and unmarred. The Contractor shall provide all cones, barrels, barricades, signs, and such other devices as deemed necessary by the Town and in conformance with the traffic management plans prepared by the Town's consultant and Section VI of the MUTCD, as amended.

#### TRAFFIC OFFICERS

Uniformed Traffic Officers will be required during the construction period. It shall be the responsibility of the Contractor to arrange for the necessary police details after the approval by the Town for each police detail required prior to ordering. This request and approval may be verbal or in writing at the discretion of the Town.

The Town will pay the exact charges for police details directly to the Dedham Police Department for details ordered by the contractor for this project.

If the Contractor fails to cancel any police detail not needed, by the required deadline as set forth by the Dedham Police Department, the cost for such detail as invoiced to the Town shall be deducted from the total reimbursement to the Contractor, unless otherwise waived by the Town due to conditions which are beyond the Contractors control.

#### WORK COORDINATION AND MEETING WITH ABUTTERS

The Contractor shall coordinate with the Town the scheduling of Public Pre-Construction meetings to be held in the late afternoon, not less than 7 calendar days prior to the start of the work. At the Public Pre-Construction meeting, the Contractor and Town will review the proposed schedule for the work, provisions for maintaining access to private property and public facilities, and provisions for public safety and traffic control.

#### TEMPORARY ACCESS TO AREA ABUTTERS

(Supplementing Subsections 8.02 and 8.06 of the Standard Specifications)

The Contractor's attention is directed to the fact that the work is in a predominantly residential and commercial business section of the Town and access to all residences and businesses must be maintained at all times.

The Contractor shall provide a safe and ready means of ingress and egress to all stores and shops, public and private buildings, professional offices and any other business or residence in the project area, both day and night, for the duration of the project.

#### WORK DONE BY OTHERS

Relocation and/or resetting to new grades of all private utilities, including utility poles, made necessary by the construction of this project, will be accomplished by the respective utility companies.

#### STORAGE OF MATERIALS AND EQUIPMENT

All excavated materials and equipment to be incorporated in the work shall be placed so as not to injure any part of the work or existing facilities and so that free access can be had at all times to all parts of the work and to all public utility installations in the vicinity of the work. Materials and equipment shall be kept neatly piled and compactly stored in such locations as will cause a minimum of inconvenience to public travel and adjoining owners, tenants and occupants. Excessive stockpiling, as determined by the Town, of excavated materials from construction will not be permitted.

#### MATERIALS REMOVED AND STACKED

All materials owned by the Town of Dedham and directed to be removed and stacked shall be carefully removed, transported and stacked (on boards) to a location within Town limits, to be determined by the Dedham Department of Public Works.

The Contractor shall be held responsible for any damage to the stacked materials before final removal. The contractor's responsibility shall cease upon final acceptance of the work or 60 days from the time a certified notice (with a copy sent to the Town) is sent to the owner of the material advising him that it is available for removal.

If the Town determines that any part of the stacked material is unsuitable for reuse, or if other

owners decide to abandon part or all of such materials, said materials shall become the property of the Contractor, and he shall dispose of them away from the site.

### DISPOSAL OF SURPLUS EXCAVATED MATERIALS

Surplus materials obtained from any type of excavation, and not needed for further use as determined by the Town, and not wanted by Town or owner, shall become the property of the Contractor and shall be legally disposed of by the Contractor outside the location subject to the regulations and requirements of local authorities governing the disposal of such materials, at no additional compensation.

### COMPUTATION OF QUANTITIES

For estimating quantities in which the computation of areas by geometric methods would be comparatively laborious, it is agreed that the planimeter shall be considered as an instrument of precision adapted to the measurement of such areas.

It is further agreed that the computation of volume of prisms shall be by the method of average end areas.

### TEMPORARY FACILITIES

The Contractor shall provide all Temporary Facilities necessary for the proper completion work, as necessary and as specified.

The Contractor's attention is directed to the requirements specified under the following sections:

- Water Supply
- Sanitary Regulations
- Drainage & Sewer Systems
- Protection Against High Water and Storm
- Temporary Heat
- Precautions during adverse weather
- Electrical Energy
- Precautions Under Electrical Lines
- Pavement Markings

All costs associated with providing Temporary Facilities that required completing the work under the contract should be included in the various Contract unit prices. No additional compensation will be made for Temporary Facilities under the contract.

### WATER SUPPLY

The Contractor shall obtain water from an approved source for all necessary operations at the site of the work, without charge therefore.

The Town of Dedham does not own the public water supply or distribution system in the Town of Dedham. All issues concerning public water supply shall be addressed to the Dedham-Westwood Water District.

### SANITARY REGULATIONS

The Contractor shall provide adequate sanitary facilities for the use of those employed on the Work. Such facilities shall be made available when the first employees arrive on the site of the Work, shall be properly secluded from public observation, and shall be constructed and maintained during the progress of the Work in suitable numbers and at such points and in such manner as may be required.

The Contractor shall maintain the sanitary facilities in a satisfactory and sanitary condition at all times and shall enforce their use. He shall rigorously prohibit the committing of nuisances on the site of the Work, on the lands of the Owner, or on adjacent property.

### TEMPORARY HEAT

If temporary heat is required for the protection of the Work, the Contractor shall provide and install suitable heating apparatus, shall provide adequate and proper fuel, and shall maintain heat as required.

### PRECAUTIONS DURING ADVERSE WEATHER

During adverse weather and against the possibility thereof, the Contractor shall take all necessary precautions so that the Work may be properly done and satisfactory in all respects. When required, protection shall be provided by use of tarpaulins, wood and building-paper shelters, or other suitable means.

During cold weather, materials shall be preheated, if required, and the materials and adjacent structure into which they are to be incorporated shall be made and kept sufficiently warm so that a proper bond will take place and a proper curing, aging, or drying will result. Protected spaces shall be artificially heated by suitable means, which will result in a moist or a dry atmosphere according to the particular requirements of the work being protected. Ingredients for concrete and mortar shall be sufficiently heated so that the mixture will be warm throughout when used.

### ELECTRICAL ENERGY

The Contractor shall make all necessary applications and arrangements and pay all fees and charges for electrical energy for power and light necessary for the proper completion of the Work and during its entire progress. The Contractor shall provide and pay for all temporary wiring, switches, connections, and meters.

The Contractor shall provide sufficient electric lighting so that all work may be done in a workmanlike manner when there is not sufficient daylight.



## DRAINAGE & SEWER SYSTEMS

The Contractor shall maintain the drainage system in the project areas to provide continual drainage of the travel ways and construction area.

It shall be the responsibility of the Contractor to repair or clean any drainage and sewer systems, which have been fouled by the Contractor's operations without additional compensation therefore.

Contractor shall accept responsibility for cleaning sewer and storm drain lines of construction related debris caused by his their activities.

All pipes and structures installed, as part of the contract shall be left in a clean and operable condition at the completion of the work.

No separate payment will be made for the maintenance of the drainage and sewer systems, but all costs in connection therewith shall be included in the unit price bid for the various Contract items.

The proposed storm water system shall be completed prior to the commencement of any other work in the contract. It is the contractor's responsibility to ensure that there be no more than a 2" difference between the existing grade and interim storm sewer grate or rim. Proposed storm sewer grates and rims shall be set to final grade no more than 72 hours prior to final paving.

The inverts and slopes of the proposed storm water system are based on utility information available to the Town at the time of design and may vary due to conditions discovered during construction. It is the contractor's responsibility to field verify all inverts prior to construction of the storm sewer system. Exploratory excavation that is required to determine a conflict between the existing utilities and the proposed storm sewer system shall be paid for under Item 141.1 - Test Pit for Subsurface Structures.

Construction of the proposed storm water system shall begin at the lowest invert and proceed upstream.

## PROTECTION AGAINST HIGH WATER AND STORM

The Contractor shall take all precautions to prevent damage to the work or equipment by high waters or by storms. The Town may prohibit the carrying out of any work at any time when in his judgment, high waters or storm conditions are unfavorable or not suitable, or at any time, regardless of the weather, when proper precautions are not being taken to safeguard previously constructed work or work in progress.

In case of damage caused by the failure of the Contractor to take adequate precautions, the Contractor shall repair or replace equipment damaged and shall make such repairs or rebuild such parts of the damaged work, as the Owner require, at no additional expense to the Owner.

### HYDRAULIC UPLIFT OF STRUCTURES

The Contractor shall be responsible for the protection of all structures against hydraulic uplift until the Owner has finally accepted such structures.

### COVERING EXCAVATED TRENCH

The Contractor shall cover all open excavations when he suspends operations at the end of the day, or in excavated trenches where work is not actually in progress. This cover shall be capable of withstanding AASHTO HS-20 loading and consist of steel plates or some other satisfactory cover of adequate size and strength suitably held in place to keep all traffic out of excavations, all as verified in writing by the Contractor. The cover shall be laid over the excavation until it is backfilled.

For any excavation expected to be in place longer than overnight, an appropriate fillet of bituminous concrete shall be installed to create a smooth transition from the road surface to the top of the plate.

The Contractor shall provide all appropriate warning signs, reflectorized drums, flashers, and other necessary safety control devices as directed by the Town. At the end of each day, all safety control devices shall be in place so that traffic flow can resume and safety is enhanced.

### BRICKS FOR DRAINAGE APPLICATION

Clay brick conforming to Section M4.052 of the Standard Specifications shall be used to adjust all manholes and catch basins frames, and grates or covers, to grade.

### COMMUNICATIONS

During paving operations, the Contractor shall provide continuous radio communication between the bituminous concrete plant and the project to ensure immediate response due to breakdowns, emergencies such as accidents, and to ensure the best quality results possible.

### PROPERTY BOUNDS

The Contractor shall exercise due care when working around all property bounds, which are to remain. Should damage or displacement to a bound result from action of the Contractor, the bound shall be replaced and/or reset to its intended position by a licensed Professional Land Surveyor at no cost to the Owner.

### PAVEMENT MARKINGS

All permanent pavement markings on public ways shall be thermoplastic unless otherwise noted on the drawings or elsewhere in these Special Provisions.

The Contractor shall provide all temporary pavement markings as may be necessary or as

directed by the Town. Payment for pavement markings shall be made at the Contract unit price for the related item actually used.

#### PROTECTION OF WORK IN PROGRESS

The Contractor shall be fully responsible assuring the final appearance of cement concrete sidewalks during the process of the work. The Contractor shall post workers at the locations of concrete sidewalk after they are freshly placed and finished and until such time that the concrete has set and is hard to the point where it cannot be easily vandalized.

Additionally, the Contractor shall keep the work areas at all locations clean of debris, dust and all excavated materials. Each working location shall be kept swept clean by the Contractor during all phases of construction and after the work is complete.

#### SAWING AND SEALING PAVEMENT AND SIDEWALK JOINTS

All edges of excavations made in existing pavements and sidewalks shall be squared by saw cutting with power driven tools to provide a neat, clean edge for joining new pavement or sidewalks. The work under this item shall include the sawing of both bituminous and cement concrete pavements and sidewalks. The Town prior to commencing work shall approve saw-cut equipment.

In areas where an existing pavement or sidewalk abuts a building, wall, or storefront and is to be reconstructed, the saw-cut shall be a minimum of six (6) inches from the building wall or storefront unless otherwise directed by the Town.

All transverse joints, and all longitudinal joints between new bituminous pavement and existing pavement to remain, shall be coated with a hot poured rubberized asphalt sealant meeting the requirements of Federal Specifications Number SS-S1401. Saw-cut surfaces in roadway areas shall be treated as specified under Subsection 460.65 of the Standard Specifications, or as directed by the Town. Rubberized asphalt sealant will not be required for temporary patches.

#### DRAINAGE & SEWER STRUCTURE CASTINGS AND GRANITE CURB

Within 30 calendar days after the award of the Contract, the Contractor shall forward to the Town written evidence that the drainage structure frames, covers and grates, and the granite curb necessary to complete the work have been ordered from a reputable supplier or manufacturer.

Upon the receipt of a notice of proposed delivery from the supplier or manufacturer, the Contractor shall forward a copy of such notification to the Town. Failure to comply with the above will nullify any request for extension of the project completion date because of late delivery.

#### INCREASED OR DECREASED CONTRACT QUANTITIES

(Supplementing Subsection 4.06 of the Standard Specifications)

This subsection changed to read as follows:

The Town reserves the right to increase or decrease the quantity of any item of work.

Unit prices provided in the Contract Proposal will be used to determine the total added cost or credits for modifications of the work performed on a unit price basis when such work is authorized in advance by the Town. The items shall include furnishing and installing, complete in place, the specified item to the satisfaction of the Town, and in accordance with the Plans, Standard Specifications and Special Provisions.

No allowances will be made for loss of anticipated profits suffered or claimed by the Contractor resulting directly or indirectly from such increased or decreased quantities or from unbalanced allocation among the Contract items from any other cause. If the quantity variation is such as to cause an increase in the Contract Time, the Contractor shall demonstrate the impact by analysis of the currently accepted Progress Schedule to the satisfaction of the Town. If the Town, through schedule analysis, determines that the Contract time should be adjusted, the Town shall within ten (10) days from the receipt of such an analysis, ascertain the facts and put into effect any necessary arrangements for Town approval of the extension of the Contract Time as in its judgment the findings justify.

#### CONTRACT RETAINAGE

(Supplementing Subsection 9.04 of the Standard Specifications)

The Contractor shall guarantee the completed job relative to workmanship and material for one year from date of project acceptance by the Town.

There will be a retainage of ten (10%) percent of the value of all planting items. For all other items of work there will be retainage of five (5%) percent of the value of all the items of work, excluding planting items. The Town will hold the above retainage for a period of one (1) year from the date of satisfactory completion of the work.

#### PRECAUTIONS UNDER ELECTRIC LINES

The Contractor's attention is directed to the AASHTO Guide on Occupational Safety on Highway Construction Projects, Subpart N, 1926.550, relating to construction equipment clearances at overhead electric lines, which states in part "...the minimum clearance between the lines and any part of the crane or load must be at least ten feet from lines rated 50 KV or below, and greater distances for higher voltage..."

For the protection of personnel and equipment, the Contractor shall be aware of this regulation especially during paving operations using large semi-trailer vehicles.

## CONSTRUCTION IN VICINITY OF SCHOOLS

Town of Dedham  
Select Board  
Policy Directive #13

### Intent of Policy

The safety of school children, teachers, and parents is of highest priority to the Town of Dedham. As a result, it is imperative that no road, sewer, storm drain, or sidewalk construction or reconstruction be undertaken in close proximity to a school building while children are entering and exiting the school property unless of an emergency nature. The intent of this policy is to establish guidelines for town and private contractors who undertake construction projects in the vicinity of school buildings for the purpose of protecting the safety of students, teachers, and parents.

### Policy Provisions

1. All bid documents and contracts relating to town-funded road, sewer, storm drain or sidewalk construction or reconstruction within 500 feet of a school shall prohibit construction activity for the period one-half hour before and after the arrival and departure of students on any day that school is in session.
2. All Street Opening Permits issued by the Director of Public Works to private parties or contractors for road, sewer, storm drain or sidewalk construction or reconstruction within 500 feet of a school shall prohibit construction activity for the period one-half hour before and after the arrival and departure of students on any day that school is in session.
3. Exceptions to policy provisions 1 and 2 above may be granted by the Director of Public Works if emergency circumstances threaten the health and safety of the public. In such cases, the Director shall ensure that proper measures are implemented to protect the safety of children, teachers and parents.



The work shall include the cold planning of existing asphalt pavement surface to various depths to produce a uniform surface for the application of the pavement overlay, as directed by the Town.

Pavement areas abutting utility structures and other areas, which cannot be planed by the principal cold planning machine, shall be excavated by manual methods. Payment shall be paid separately under Item 129.2 Old Pavement Excavation.

No cold-planed asphalt cuttings shall remain on the project at the end of each workday, except as might be acceptable for base at the approval of the Town. Cold-planed materials are the property of the Town of Dedham; the Town of Dedham may direct the contractor to transport the cold-planed material to other sites within the Town for reuse at no extra cost to the Town. If the Town does not choose the use of the cold-planed materials, the cold-planed materials shall become the property of the Contractor and shall immediately be removed from the site at the contractor's expense.

All surfaces, which have been cold-planed, shall be swept clean to remove smaller shavings prior to the opening of the roadway or section of the roadway to traffic. No additional payment will be made for sweeping and cleaning of the cold-planed areas.

Hot Mix Asphalt installation shall be as directed.

Payment shall be paid for separately under Item 460. Hot Mix Asphalt Pavement.

#### Payment

Payment for work under this item shall be made at the Contract unit bid price per square yard and shall include full compensation for furnishing all labor, material and equipment, removal and disposal of unwanted material, sweeping and cleaning of the planed areas, and any other incidental items necessary for the satisfactory completion of this work as specified.

#### **ITEM 129.2 OLD PAVEMENT EXCAVATION**

#### **SQUARE YARD**

Work under this item shall conform to the relevant provisions of Section 100 of the Massachusetts Highway Department 2021 Standard Specifications for Highways & Bridges, the latest supplements and addendum thereto, and the following:

The work under this item is specifically designated for existing pavement that is to be removed by methods other than cold planning at various locations throughout the town. Work shall include the removal of the existing asphalt pavement surface to its full depth. Removed material shall become the property of the Contractor and shall immediately be removed from the site and disposed of legally.

If the Town deems that additional base material is needed, the Contractor shall place dense graded crushed stone to the limits directed by the Town. Payment shall be paid for separately under Item 402. Dense Graded Crushed Stone for Sub-Base.

The subgrade shall be shaped to a true surface conforming to the existing cross section of the roadway, or as directed by the Town. Payment shall be paid for separately under item 170. Fine Grading and Compacting.

Hot Mix Asphalt installation shall be as directed.

Payment shall be paid for separately under Item 460. Hot Mix Asphalt Pavement.

Payment

Payment for work under this item shall be made at the Contract unit bid price per square yard and shall include full compensation for furnishing all labor, material and equipment, removal and disposal of unwanted material, sweeping and cleaning of the areas, and any other incidental items necessary for the satisfactory completion of this work as specified.

<b>ITEM 220.</b>	<b>DRAINAGE STRUCTURE ADJUSTED</b>	<b>EACH</b>
<b>ITEM 220.2</b>	<b>DRAINAGE STRUCTURE REBUILT</b>	<b>VF</b>
<b>ITEM 220.5</b>	<b>DRAINAGE STRUCTURE REMODELED</b>	<b>EACH</b>
<b>ITEM 220.6</b>	<b>SANITARY STRUCTURE REBUILT</b>	<b>VF</b>
<b>ITEM 220.7</b>	<b>SANITARY STRUCTURE ADJUSTED</b>	<b>EACH</b>
<b>ITEM 220.8</b>	<b>SANITARY STRUCTURE REMODELED</b>	<b>EACH</b>

Work under this item shall conform to the relevant provisions of Section 200 of the Massachusetts Highway Department 2021 Standard Specifications for Highways & Bridges, the latest supplements and addendum thereto, and the following:

All structure adjustments and rebuilds shall comply with the Dedham DPW Design & Construction Standards. All castings, including gate boxes, located within the pavement area shall not be set to finish grade until after the binder course has been placed.

The brick for structure adjustment and rebuilding shall be sound, hard and uniformly burned brick, regular and uniform in shape and size, of compact texture and satisfactory to the Town. Brick shall comply with ASTM Standard Specifications for sewer brick (made from clay or shale), Designation C-32-63 or Grade SA, hard brick, except that the mean of five tests for absorption shall not exceed 8 percent by weight. Rejected brick shall be immediately removed from the work site and brick satisfactory to the Town substituted.

Payment

Payment for work under this item shall be made at the Contract unit bid price per each or per vertical foot as indicated above, and shall include full compensation for furnishing all labor,



materials and equipment, excavations, and any other incidental items for the satisfactory completion of this work as specified.

**ITEM 403. RECLAIMED PAVEMENT FOR BASE COURSE SQUARE YARD  
AND/OR SUB-BASE**

Work under this item shall conform to the relevant provisions of Section 403 of the Massachusetts Highway Department 2021 Standard Specifications for Highways & Bridges, the latest supplements and addendum thereto, and the following:

Removal and disposal of unsuitable material, surplus reclaimed material, or any sub-base/subgrade material necessary for grade changes shall be paid for at the contract unit price per cubic yard for Item 120.1, Unclassified Excavation only when removed and disposed of by the contractor. Loading of Town owned or contracted vehicles for disposal by the Town with unsuitable material, surplus reclaimed material, or any sub-base/subgrade material necessary for grade changes shall be considered incidental to this item and no additional compensation will be allowed.

Grading and compacting the sub-base and/or subgrade resulting from the removal of surplus reclaimed material shall be considered incidental to this item and no additional compensation will be allowed.

**ITEM 460.01 ASPHALT PAVEMENT-MARSHALL MIX TON**  
**ITEM 460.02 ASPHALT PAVEMENT-SUPERPAVE TON**

**Special Notice to Bidders**

**The bidder's attention is directed to the following:**

**The Town reminds all bidders that they are required to call the Department of Public Works to schedule inspection of newly placed asphalt. Failure to contact the Department shall result in material rejection and the Contractor shall be required to remove and replace all material at no additional cost to the Town.**

**The Contractor shall assume that ALL asphalt in this contract be produced as Warm Mix Asphalt unless otherwise directed by the Engineer.**

**1.0 DESCRIPTION**

**1.1 Scope** - Work under this item shall consist of furnishing asphalt composed of mineral aggregate and asphalt binder, mixed in a central mixing plant and placed on a prepared course in accordance with these specifications and conformance to the lines, grades, thickness and typical cross sections shown on the plans or as directed by the Engineer. Where reference is made to

MHD Standard Specifications, Form 1995 shall apply for section references; latest edition shall apply for specifications.

Each course shall be constructed to the depth, typical section, or elevation required by the contract and/or plans, or as directed and shall be rolled, finished, and approved before the placement of the next course. Each course shall be placed to a smooth, dense and uniform appearance.

Many state agencies are implementing Quality Assurance specifications. It is the intent of these municipal quality-based WMA/HMA specifications to move toward the goal of quality assurance implementation but tailored toward the real world of municipal construction. To that end, the Contractor is required to establish, provide, and maintain a Quality Control System (QCS) that will detail the methods and procedures that will be taken to assure that all materials and completed construction conform to project specifications, plans, technical specifications and other requirements, whether manufactured or processed by the Contractor or procured from subcontractors or vendors.

## 2.0 QUALITY ASSURANCE

The Contractor assumes the responsibility of the quality for all materials and construction incorporated into the work and will control all the processes leading to the final result through this function. Quality Control activities should include:

Maintain a Contractor Quality Control System

Proficiency testing prior to/during production with Engineer

Inspection and Testing of Asphalt Production

Inspection and Testing of Asphalt Placement

See Section 7.16 "Contractor Quality Control of WMA/HMA Pavement" of these specifications for additional information.

The Town of Dedham or their authorized agent will perform the Quality Acceptance function for this work. Material will be considered for acceptance through a sampling, testing and inspection program performed by the Engineer or their agent. Quality Acceptance activities include:

Proficiency testing prior to/during production with Contractor,

Inspection of WMA/HMA Production Plant and Testing Laboratory.

Production Trials of WMA/HMA Products Intended for Use in the Town of Dedham or approved, current MHD job mix formulas and related Marshall approved design.

Inspection/Testing for Acceptance of Asphalt Production

## Inspection/Testing for Acceptance of Asphalt Placement

### WMA/HMA Quality Acceptance Report of Activities

#### 3.0 MATERIALS

3.1 Aggregate - Aggregate shall meet the requirements of MHD M3.11.04 latest edition of the Standard Specifications and as further stipulated herein.

##### A. Coarse Aggregate

1. The sodium sulfate soundness loss shall not exceed nine (9) percent, nor the magnesium soundness loss exceed twelve (12) percent, after five cycles, when tested in accordance with AASHTO T104.
2. The coarse aggregate shall not contain more than one (1) percent of material such as crusher dust, sand or soft, disintegrated pieces. The coarse aggregate shall not contain more than ten (10) percent, by weight, of flat or elongated pieces, when tested in accordance with ASTM D4791 at a ratio of 3:1.
3. The aggregate shall contain a minimum coarse aggregate angularity of 75% having at least one fractured face for the base, intermediate courses and surface course, when tested in accordance with ASTM D5821.
4. The use of steel slag or blast furnace slag shall not be permitted as a coarse aggregate.

##### B. Fine Aggregate

1. Fine aggregate shall consist of clean, sound, durable, angular particles produced by crushing natural stone, or gravel that meets the requirements for wear and soundness specified for the coarse aggregate. The aggregate particles shall be free from coatings of clay, silt, or other objectionable matter and shall contain no clay balls. The combined materials that passed the No. 100 mesh sieve shall not have sufficient plasticity to permit the performing of the plastic limit test using AASHTO T90.
2. Fine aggregates shall have sand equivalent values of 40 or greater when tested in accordance with AASHTO T176. The sand equivalent value shall be determined for the combined mix aggregates, including coarse and fine aggregates and mineral filler portions.

3. Natural (non-manufactured) sand may be used to obtain the gradation of the aggregate blend or to improve the workability of the mix. The amount of sand to be added will be adjusted to produce mixtures conforming to requirements of this specification.

- C. Mineral Filler: If filler, in addition to that naturally present in the aggregate, is necessary, it shall meet the requirements of AASHTO M17.

WMA/HMA mixtures shall contain a dust to effective asphalt ratio by mass between 0.6 and 1.2. For Superpave designed mixtures, mixtures that pass beneath the Primary Control Sieve (PCS) control point established by AASHTO M323 may contain a dust to effective asphalt ratio by mass between 0.8 and 1.6.

- D. Reclaimed Asphalt Pavement (RAP) The use of a maximum of 15% recycled asphalt pavement (RAP) will be allowed in the WMA/HMA surface courses. All other WMA/HMA mixtures may contain a maximum of 25% RAP by mass of the entire mixture.

The RAP, incorporated into the WMA/HMA mixtures, shall be maintained as a separate captive stockpile and shall not be added to without prior approval. RAP shall consist of asphalt pavement recovered by cold milling or other removal techniques. The RAP shall be crushed so that 100 percent passes the maximum aggregate size of the WMA/HMA mix in which it will be used. The Contractor's Quality Control system shall assure that the RAP is free from detrimental amounts of contaminating substances such as joint seal compound and, is reasonably uniformly graded from fine to coarse.

The coarse aggregate in the RAP shall be crushed stone or crushed gravel and the top-size shall not exceed the maximum aggregate size established by the JMF. The final WMA/HMA mixture containing RAP shall conform to all the specification requirements contained herein.

For mixtures containing 15% or less RAP, the asphalt binder shall be a PG 64-28 or PG 64-22. For mixtures containing greater than 15% and up to 25% RAP, the asphalt binder grade shall be a PG 58-34, or that which satisfies AASHTO MP1 and AASHTO MP2.

The laboratory RAP-virgin binder blend viscosity value established from the RTFO residue at 140°F (60°C) shall establish the maximum viscosity allowed for the binder after discharge from the WMA/HMA plant and/or silo storage, if applicable, when recovered by AASHTO T170 and tested in accordance with AASHTO T202 and AASHTO TP48.

For design purposes, the specific gravity of the combined aggregate blend with RAP used in a WMA/HMA mixture shall be determined in accordance with the

test method for BULK SPECIFIC GRAVITY OF AGGREGATE BLENDS WITH RAP (contact Town if a copy of this test method is needed).

3.1.1 Sampling and Testing - All aggregate samples required for testing shall be furnished by the Contractor when requested. AASHTO-T2 shall be used in sampling coarse aggregate and fine aggregate, and AASHTO T127 shall be used in sampling mineral filler. All tests for initial aggregate submittals necessary to determine compliance with requirements specified herein will be conducted by the Contractor under their Quality Control System. No aggregate shall be used in the production of mixtures without prior approval.

3.1.2 Sources of Supply - Previously approved MHD sources shall be used. Contractor to document MHD approvals.

3.2 Asphalt Binder Material - The types, grades, and controlling specifications, the maximum mixing temperatures and compaction temperatures for the asphalt binder materials shall conform to the following:

3.2.1 Performance Graded Asphalt Binder: - The Asphalt Binder shall be a Performance Graded Asphalt Binder (PGAB) which meets the specification requirements of AASHTO M320 and AASHTO R29. Acceptance of the PGAB will be in accordance with AASHTO R26 "Standard Practice for Certifying Suppliers of Performance Graded Asphalt Binders". PGAB shall be provided by an Approved Supplier (AS) under the Approved Supplier Certification (ASC) system.

THE PGAB GRADE SELECTED FOR THIS WORK IS PG 64-28 or 64 -22 - If heavy truck traffic and high volume traffic levels warrant, the PGAB may be adjusted by the Engineer for the Town of Dedham traffic conditions.

1. A separate JMF with TSR results shall be submitted for each PGAB grade proposed for use on this project.
2. Limit one binder grade per production day unless otherwise adjusted by the Engineer for the Town of Dedham traffic conditions.
3. Documentation of the type of binder used per production day is to be stated on the weigh slips.

The Contractor shall furnish manufacturers' certified test reports for each carload or equivalent of binder shipped to the project as well as applicable Materials Certificates for the shipment of each carload or equivalent to the production plant. The reports shall be delivered to the Engineer before production of the WMA/HMA. The furnishing of the vendor's certified test reports and material certificates for the PGAB material can be used as the basis for final acceptance of the bituminous material, or, tested by the Engineer. If the Engineer elects to test the binder material at their costs, then the Contractor shall set aside one (1) 1-qt samples of the asphalt binder material obtained from each truckload, shipment, or equivalent of asphalt binder material shipped to the production facility. Each sample shall be labeled with the PG grade, source and batch number, quantity,

project name, plant, date, and the sampling inspector. The Contractor shall maintain documentation in the form of a Materials Certificate of each shipment, with a copy attached to each quart sample.

After receiving the quart samples, obtained by the Contractor, the Engineer may test the samples for verification of the performance grade. Material shall conform to the specification requirements for the applicable performance grade as specified herein. Material not conforming to specification requirements shall be subject to corrective action, production suspension, rejection, removal, or reduced payment as determined by the Engineer.

The blending at the WMA/HMA plants of PG binder from different suppliers is strictly prohibited. Contractors may switch to another approved source of PG binder, upon written notification to the Engineer, and by certifying that the tank to be utilized has been drained to an un-pumpable condition. The tank shall not retain more than 0.5% in volume capacity of previous residue source. Contractors who blend PG binders will be reclassified as a supplier and required to certify the binder in accordance with AASHTO M320 and AASHTO R26. Also if any modifications, blending, or addition of additives occurs, the Contractor shall re-certify the material in accordance with AASHTO M320 and AASHTO R26.

A copy of the Certified Test Reports shall be provided in accordance with the frequency requirements established in the latest version of AASHTO M320, and shall include the following:

- 1) Flash point
- 2) Rotational viscosity at 275°F and 329°F
- 3) Specific gravity at 77°F
- 4) Original  $G^*/\sin\delta$  and phase angle at test temperature
- 5) RTFO percent mass loss
- 6) RTFO -  $G^*/\sin\delta$  and phase angle at test temperature
- 7) PAV Residue -  $G^*(\sin\delta)$  and phase angle at test temperature
- 8) Creep stiffness and m-value at test temperature
- 9) Direct tension results (when equipment available)
- 10) Strain sweep in accordance with AASHTO T315 (optional)
- 11) Physical hardening after 24 hours in accordance with AASHTO T313 (optional)

3.2.2 Latex Modifier - The latex compound used in conjunction with the asphalt binder for Ultra-thin surface shall be a cold polymerized unvulcanized virgin synthetic rubber in latex form and conform to the following requirements:

LATEX COMPOUND

Type of Latex	Anionic
Total Rubber Solids, % by weight	60 – 72
Ash, % of total rubber solids by weight	3.5 max.

pH	9 - 11
Viscosity, Brookfield #2 @ 20 rpm, 77F	2,000 max.
Styrene Butadiene Ratio	24:76 $\pm$ 2
Residual Styrene, % by weight	0.1 max.

The manufacturer of the latex compound shall furnish certification showing actual test results conforming to the specifications. The Contractor shall submit typical samples of the latex compound and the unmodified bitumen to be used for the project to the Engineer prior to production.

3.2.3 Warm Mix Additives (WMA) - Warm Mix Additives shall be added to the Job-Mix Formula unless otherwise directed by the Engineer. No other changes shall be made in the Job-Mix Formula when adding WMA additives unless required by the Engineer.

Only Warm Mix Additives listed on the NEAUPG Qualified WMA Technologies list will be accepted, and shall be limited to chemical additives which are capable of reducing mixture compaction temperatures by a minimum of 50° F. Additives possessing anti-stripping properties are preferred.

3.2.4 Asphalt Binder Anti-Stripping Additive - MHD approved anti-strip additive shall be used.

3.2.5 Tack Coat: Emulsified asphalt; AASHTO M140/ASTM D 997 or AASHTO M 208/ASTM D 2397, RS-1 or CRS-1

3.3 PRELIMINARY MATERIAL ACCEPTANCE: Prior to delivery of WMA/HMA materials to the job site, the Contractor shall submit either an approved, current MHD job mix formulas for the mixtures to be used, or, certified test reports to the Engineer for the following materials certified under the Contractor's quality control system:

#### 3.3.1 Coarse Aggregate

- A. Percent of wear
- B. Soundness
- C. Flat and Elongated
- D. Coarse aggregate angularity

#### 3.3.2 Fine Aggregate

- A. Liquid limit
- B. Plastic index
- C. Sand equivalent
- D. Fine aggregate anularity

#### 3.3.3 Mineral Filler

3.3.4 Performance Graded Asphalt Binder: The certification(s) shall show the appropriate AASHTO and/or ASTM test(s) for each material, the test results, and a signed statement that the material meets the specification requirement.

3.3.5 The Engineer may request samples for testing, including but not limited to, modifiers, truck coatings, and emulsion, prior to and during production, to verify the quality of the materials and to ensure conformance with the applicable specifications.

#### 4.0 COMPOSITION OF WMA/HMA MIXTURES

4.1 Asphalt – WMA/HMA plant mix may be composed of a homogeneous mixture of aggregate, filler if required, bitumen, and/or additives, combined to meet the composition limits by weight and other characteristics as specified. The several aggregate fractions shall be sized, uniformly graded and combined in such proportions that the resulting mixture meets the grading requirements of these specifications.

4.2 Asphalt Mix Design: The Contractor shall be responsible for the development of all job mix formulas. All job mix formulas other than for Surface Treatment and Base mix shall be based on and supported by volumetric mix designs, either Marshall Method or Superpave method. Marshall Mix design method, procedures and criteria shall be based on Asphalt Institute MS-2 and AASHTO T245 and the requirements contained herein. Superpave mix designs shall be based on Asphalt Institute SP-2 and AASHTO M323, R35, R30, T312, and the requirements contained herein. For the Superpave volumetric mix design, the mixture of asphalt and aggregate shall be oven aged at the mixture's specified compaction temperature in accordance with AASHTO R30.

4.3 JOB MIX FORMULA (JMF). Work shall not begin nor shall any mixture be accepted until the Contractor has submitted a job mix formula, samples of the existing and new materials intended for use, and has established a separate, job mix formula (JMF) for each mixture. A separate job mix formula shall be submitted for each mixture and each approved RAP stockpile (the stockpile shall be of a uniform quality throughout).

4.3.1 JMF Submittal - The job mix formula shall establish the percentage of each additional aggregate required, a single percentage of aggregate passing each required sieve size, a single percentage and the grade of asphalt binder to be added, the percentage of recycling additive, and a single temperature at which the mixture is to be discharged from the plant, and the number of seconds for dry mixing time and the number of seconds for wet mixing time. AASHO-T195 (Ross Count) with a coating factor of ninety-eight (98) percent will be used when necessary to evaluate proper mixing time. The moisture content of all Asphalt upon discharge from the mixer shall not exceed 0.5 percent when tested in accordance with AASHTO T110. The job mix formula shall also specify a single source or uniform blend of particular sources for fine aggregate, a single source for each nominal size of coarse aggregate, and a single source of supply for mineral filler and



for asphalt. The JMF shall be submitted in writing by the Contractor to the Engineer at least 30 days prior to the start of paving operations and shall include as a minimum:

- A. Percent passing each sieve size.
- B. Percent of asphalt binder.
- C. Performance grading test results and Material Certificate certifying the PG grade.
- D. Number of gyrations for the estimated design ESAL loading.
- E. Mixing temperature.
- F. Compaction temperature.
- G. Temperature of mix when discharged from the mixer.
- H. Plot of the combined gradation on the Federal Highway Administration (FHWA) 0.45 power gradation curve.
- I. Percent natural sand.
- J. Percent fractured faces.
- K. Percent flat or elongated particles.
- L. Tensile Strength Ratio (TSR).
- M. Antistrip agent – type and quantity.
- N. Sand equivalent value.
- O. Fine aggregate angularity value.
- P. Percentage of wear.
- Q. Sulfate soundness loss.
- R. Individual and combined aggregate specific gravity.
- S. Dust to effective asphalt ratio.
- T. Graphical plot of air voids, voids in mineral aggregate (VMA), and voids filled with asphalt (VFA) versus asphalt content. The Superpave mixes shall also show density at  $N_{\text{initial}}$ , density at  $N_{\text{design}}$ , and density at  $N_{\text{maximum}}$  versus asphalt content

The Contractor shall submit samples to the Engineer, upon request, for JMF verification testing.

The JMF for each mixture shall be in effect until modified in writing by the Engineer. Should a change in sources of materials be made, a new JMF must be approved by the Engineer before the new material is used.

4.3.2 JMF Tolerances - The job mix formula, operating within the allowable action limits for individual measurements as specified in Table 7 herein, shall be set within the design master limits specified for each mixture class, either Table 5 for Superpave design or Table 6 for Marshall design except that the Engineer may modify the design limits if they determine this to be necessary and in the best interest of the Town of Dedham.

4.3.3 Plant Trial Mixtures - After receiving the job mix formula prepared by the Contractor, the Engineer will notify the Contractor regarding a verification of the optimum asphalt content and/or pre-production trials and Control Section for those mixtures so designated by the Engineer. A minimum of one trial mix shall be produced at the Contractor's proposed asphalt binder content and aggregate gradation.

**4.3.4 JMF Approval** – The Contractor will be notified by the Engineer if the JMF submittals are approved for production. The approved job mix formula for the mixture shall be in effect until modified in writing. As indicated in Section 4.3.3, Plant Trial Mixtures, of this specification, the Engineer will notify the Contractor regarding the placement of a Control Section (See Section 5.0). Following placement and testing of the Control Section, the JMF may have to be modified to meet both production and placement requirements of this specification. If warranted, the JMF resubmittal shall follow the applicable requirements of Section 4.3 of this specification. A JMF, once approved, will not be required for further mix approval for the construction season unless a change has occurred that warrants a new JMF approval or as directed by the Engineer. The approval of all JMFs will terminate on December 31<sup>st</sup> each year, regardless if the work is carried over to the following year. Control strips are required by the contractor for in-place mat thickness, uniformity, longitudinal joint characteristics, and density requirements before approval.

4.4 WMA/HMA Mixture Design Criteria

<b>TABLE 3. PERCENT VOIDS IN MINERAL AGGREGATE (VMA)</b>	
Nominal Maximum Aggregate Size	Percent Minimum
#4 (4.75mm)	16.0
3/8" (9.5 mm)	15.0
1/2" (12.5 mm)	14.0
3/4" (19.0 mm)	13.0
1.0" (25.0 mm)	12.0

**TABLE 4: Asphalt and Volumetric Properties for Superpave Mixtures.**

Traffic Levels	Design ESALs (million)	Number of Gyration by Superpave Gyrotory Compactor			Percent Density of Gmm from WMA/HMA specimen			Voids Filled with Asphalt (VFA) Based on Nominal mix size					
		Nini	Ndes	Nmax	Nini	Ndes	Nmax	4.75 mm	9.5 mm	12.5 mm	19.0 mm	25.0 mm	37.5 mm
1	< 0.3	6	50	75	≤ 91.5	95 - 97	≤ 98.0	70 - 80	70 - 80	70 - 80	70 - 80	67 - 80	64 - 80
2	0.3 to < 3.0	7	75	115	≤ 90.5	95 - 97	≤ 98.0	65 - 78	65 - 78	65 - 78	65 - 78	65 - 78	64 - 78
3	3.0 to < 30	8	100	160	≤ 89.0	95 - 97	≤ 98.0	75 - 78	73 - 76	65 - 75	65 - 75	65 - 75	64 - 75
4	≥ 30.0	9	125	205	≤ 89.0	95 - 97	≤ 98.0	75 - 78	73 - 76	65 - 75	65 - 75	65 - 75	64 - 75

<b>TABLE 5. SUPERPAVE ASPHALT MIXTURES</b>												
	<b>Percent by Weight Passing Sieves</b>											
<b>Sieve Size in. (mm)</b>	<b>4.75mm</b>		<b>9.5mm</b>		<b>12.5mm</b>		<b>19.0mm</b>		<b>25.0mm</b>		<b>37.5mm</b>	
	<b>Control Points</b>		<b>Control Points</b>		<b>Control Points</b>		<b>Control Points</b>		<b>Control Points</b>		<b>Control Points</b>	
	<b>Min %</b>	<b>Max %</b>	<b>Min %</b>	<b>Max %</b>	<b>Min %</b>	<b>Max %</b>	<b>Min %</b>	<b>Max %</b>	<b>Min %</b>	<b>Max %</b>	<b>Min %</b>	<b>Max %</b>
2" (50.0)									-	-	100.0	
1-1/2" (37.5)	-	-	-	-	-	-	-	-	100	-	90.0	100.0
1" (25.4)	-	-	-	-	-	-	100.0	-	90.0	100.0	-	90.0
3/4" (19.0)	-	-	-	-	100.0	-	90.0	100.0	-	90.0	-	-
1/2" (12.5)	100.0	-	100.0	-	90.0	100.0	-	90.0	-	-	-	-
3/8" (9.5)	95.0	100.0	90.0	100.0	-	90.0	-	-	-	-	-	-
#4 (4.75)	90.0	100.0	-	90.0	-	-	-	-	-	-	-	-
#8 (2.36)	-	-	32.0	67.0	28.0	58.0	23.0	49.0	19.0	45.0	15.0	41.0
#16 (1.18)	30.0	60.0	-	-	-	-	-	-	-	-	-	-
#30 (0.600)	-	-	-	-	-	-	-	-	-	-	-	-
#50 (0.300)	-	-	-	-	-	-	-	-	-	-	-	-
#100 (0.150)	-	-	-	-	-	-	-	-	-	-	-	-
#200 (0.075)	6.0	12.0	2.0	10.0	2.0	10.0	2.0	8.0	1.0	7.0	0	6.0
<b>Dust to Binder Ratio<sup>(Note)</sup>:</b>	0.9	2.0	0.6	1.2	0.6	1.2	0.6	1.2	0.6	1.2	0.6	1.2

**Note:** The Engineer may increase the Dust to binder ratio from 0.6-1.2 to 0.8-1.6 if the proposed aggregate gradation passes beneath the Primary Control Sieve (PCS) control point established in AASHTO M323.

**Table 6. MARSHALL DESIGN MASTER RANGE TOLERANCES**

Standard Sieves	Base Course	Dense Binder Course	Modified Arterial Top	Top Course	Dense Mix	Surface Treatment	Ultra-Thin Surface (c)
2" (50mm)	100						
1-1/2"(38mm)							
1" (25mm)	57-87	100					
3/4" (19mm)		80 - 100	100				
1/2" (12.5mm)	40-65	65 - 80	90-100	100	100		100
3/8" (9.5mm)			70-90	80-100	80-100	100	90 - 100
#4 (4.75mm)	20-45	48 - 65	45-70	50-76	55-80	80-100	55 - 85
#8 (2.36mm)	15-33	37 - 51	28-55	37-54	48-63	64-85	32 - 47
#16 (1.18mm)			18-40	26-40	36-49	46-68	18 - 31
#30 (0.60mm)	8-17	17 - 30	10-30	17-31	24-38	26-50	11 - 22
#50 (0.30mm)	4-12	10-22	6-23	10-23	14-27	13-31	7 - 18
#100 (0.15mm)			4-15	6-16	6-18	7-17	4 - 12
#200 (.075mm)	0-4	0-6	2-7	2-7	4-8	3-8	3 - 10
Asphalt Content	4.0-5.0	5.0-6.0	5.0-7.0	5.5-7.0	7.0-8.0 (a)	7.0-8.0	6.5-8.0(b)
Temp. Mix (F)	255-295	265-325	265-325	265-325	265-325	275-325	330 - 360
Temp.Mix (C)	124-146	129-163	129-163	129-163	129-163	135-163	166-182
Marshall Blows	N/A	50	75	50	50	N/A	50
Stability, lbs. min		1000	1500	1000	1000		1800
Stability, Newtons		4500	6750	4500	4500		8000
Flow,0.01"(.25mm)		8-16	8-16	8-16	8-16		8-16
AirVoids,%		3.0 - 6.0	3.0 - 5.0	3.0 - 6.0	3.0 - 6.0		3.0 - 5.0

Table 6 Notes:

- (a) Dense mix including approved anti-stripping compound shall be furnished and used for protective (bottom) courses of pavement on bridges, and elsewhere shown on the plans.
- (b) The total asphalt content in this mixture shall contain  $5\% \pm 0.5\%$  of rubber solids.
- (c) The aggregates used for the production of the Ultra-Thin Surface will contain all crushed aggregates, natural sand is not allowed.

**The asphalt content of all mixtures shall be calculated on the percentage basis by weight of the total mix.**

4.5 Additional WMA/HMA Criteria – In addition to the above WMA/HMA design requirements, the WMA/HMA mixtures shall also conform to the following:

- A. Stripping: Each mixture shall be evaluated for stripping by performing indirect tensile tests on compacted mixtures. If the Tensile Strength Ratio (TSR) of the composite mixture, as determined by AASHTO T283 with freeze/thaw, is less than 80, the aggregates shall be rejected or the asphalt treated with an approved anti-stripping agent. The amount of anti-stripping agent added to the asphalt shall be sufficient to produce a TSR of not less than 80. If an antistripping agent is required, it will be provided by the Contractor at no additional cost.
- B. Aggregate Composition: The mineral aggregate shall be of such size that the percentage composition by weight, as determined by laboratory sieves, will conform to the gradation or gradations specified in either Table 5 or Table 6, whichever is applicable, when tested in accordance with AASHTO Standards T27 and T11. The gradations in either Table 5 or 6, whichever is applicable, represent the limits which shall determine the suitability of aggregate for use from the sources of supply. The aggregate, as selected (and used in the JMF) and blended, shall have a gradation within the limits designated in either Table 5 or 6, whichever is applicable, and shall not vary from the low limit on one sieve to the high limit on the adjacent sieve, or vice versa, but shall be well graded from coarse to fine.
- C. JMF Deviations: Deviations from the final approved mix design for asphalt binder content and gradation of aggregates shall be within the action limits for individual measurements as specified in Table 7. The limits still will apply if they fall outside the master grading band in Table 5 or 6, whichever is applicable.
- D. Minimum Lift Thickness Consideration: The maximum size aggregate used shall not be more than one-half of the compacted thickness of the course being constructed on a prepared surface or that which can be placed to achieve

specification requirements. The maximum size is defined as one sieve size larger than the nominal maximum size. The nominal maximum size is defined as one sieve size larger than the first sieve to cumulatively retain more than 10 percent.

- E. WMA/HMA may be stored in surge or storage bins provided that the mixture used from the bins is of a uniform quality and meets the following requirements:

Temporary Storage of Bituminous Mixture - Use of surge bins or storage bins for temporary storage of Asphalt will be permitted as follows:

1. The Asphalt mixture may be stored in surge bins for a period of time not to exceed three hours.
2. The Asphalt mixture may be stored in insulated and heated storage bins for a period of time not to exceed twelve hours, provided an inert gas atmosphere is maintained in the bin during the storage period.
3. If the Engineer determines that there is an excessive amount of heat loss, segregation and/or oxidation of the mixture due to temporary storage, use of surge bins or storage bins will be discontinued.

In addition, the recovered asphalt from the mix samples obtained 30 days after production shall meet the following requirements:

RECOVERED ASPHALT  
ASTM D1856  
ABSON METHOD

<u>Test Property</u>	<u>Min.</u>	<u>Max.</u>
Viscosity, poises @ 140F.		6000
Penetration, dmm @ 77F.	45	100
Ductility, cm @ 77F.	75	
T <sub>max</sub> for G*/Sin (d) DSR (RTFO Aged)	-	One Grade Higher

**5.0 WMA/HMA CONTROL SECTION.** Prior to full production for the Town, the Contractor shall place a quantity of Asphalt according to the JMF and the project specifications. The amount of mixture should be sufficient, at a minimum, to construct a test section 300 feet long and 20 to 30 feet wide placed in two lanes, with a longitudinal joint, and shall be of the same depth specified for the construction of the course which it represents. The underlying grade or

pavement structure upon which the Control Section is to be constructed shall be the same as the remainder of that project course represented by the Control Section. The equipment used in construction of the Control section shall be the same type and weight to be used on the remainder of the course represented by the Control Section. The control strip may be as large as one production day on a Town street as long as a longitudinal joint has been constructed.

Two Random sample(s) shall be taken at the plant by the Engineer and tested for air voids in accordance with the Section 8.10, Plant-Produced Material. One random sample of mixture shall be taken at the plant and tested for aggregate gradation and asphalt binder content in accordance with the Section 8.10 Plant-Produced Material.

Three randomly selected cores shall be taken from the finished pavement mat in the Control Section, and three from the longitudinal joint, and tested in accordance with Section 8.2, Field Placed WMA/HMA Material. Random sampling shall be in accordance with procedures contained in ASTM D3665.

Mat density and air voids shall be evaluated in accordance with Section 8.2, Field Placed WMA/HMA Material.

The performance control strip shall be considered acceptable if the uniformity, thickness, longitudinal joint density and mat density, and plant air voids are within the requirements of this specification.

**If the initial Control section should prove to be unacceptable, the necessary adjustments to the JMF, plant operation, placing procedures, and/or rolling procedures shall be made. A second Control section shall then be placed. If the second test section also does not meet specification requirements, both sections shall be removed at the Contractor's expense. Additional Control sections, as required, shall be constructed and evaluated for conformance to the specifications. Any additional sections that are not acceptable shall be removed at the Contractor's expense. Full production shall not begin until an acceptable section has been constructed and accepted by the Engineer. The initial Control section, whether acceptable or unacceptable, and any subsequent section that meets specification requirements shall be paid for in accordance with the Section 10.0 PAYMENT.**

Job mix formula quality control testing is to be performed by the Contractor at the start of plant production and in conjunction with the calibration of the plant for the JMF. It should be recognized that the aggregates produced by the plant might not satisfy the gradation requirements or produce a mix that exactly meets the JMF. In those instances, it will be necessary to re-evaluate and re-design the mix using plant-produced aggregates. Specimens should be prepared and the optimum asphalt binder content determined in the same manner as for the original design tests. A revised JMF will need to be submitted and a test section constructed prior to approval and full production. The test section and JMF submittal shall conform to all the specification requirements contained herein.

## 6.0 EQUIPMENT



6.1 Asphalt Mixing Plant - Shall meet MHD M3.11.07.

- A. Sampling Platform: A safe and adequate platform or catwalk with stairway and railing shall be provided to accommodate the inspector while checking temperatures and obtaining samples of the mixture from haul vehicles. The height of the platforms and raised platforms shall be adequate to accommodate safe acquisition of mix samples from the type of hauling unit(s) being utilized on the project.
- B. Testing Laboratory - The Contractor or producer shall provide a testing laboratory at the production plant for quality control and quality acceptance functions during periods of mix production, sampling, and testing, and whenever materials subject to the provisions of these specifications are being supplied or tested. The laboratory shall contain adequate equipment, space, and utilities as required for the performance of the specified tests.

It shall be available for joint use by the Contractor for quality control testing, if applicable, and by the Engineer for acceptance testing. And must have adequate equipment for the performance of the tests required by these specifications and the requirements of NETTCP. The Engineer shall have priority in use of the equipment necessary for acceptance testing. All the necessary testing equipment shall be located at the WMA/HMA plant supplying material to the project. In addition, all ancillary and miscellaneous equipment needed to perform the testing in accordance with these specifications shall be provided by the Contractor at no additional cost.

The effective working area of the laboratory shall be a minimum of 150 square feet with a ceiling height of not less than 7.5 feet. Lighting shall be adequate to illuminate all working areas. It shall be equipped with heating and air conditioning units to maintain a temperature of  $70^{\circ}\text{F} \pm 5^{\circ}\text{F}$ .

The plant laboratory shall further contain and be kept supplied with the following laboratory equipment:

Balance: 20,000gm capacity minimum, sensitivity 0.1gm.

Marshall Equipment: Automatic Asphalt compactor mounted in accordance with ASTM D1559 and conforming to specifications for AASHTO T-245 which consists of totally enclosed, rigidly mounted operated frame, a standard circular-foot compaction hammer assembly designed to ensure an eighteen (18) inch drop regardless of specimen height, a one third (1/3) horsepower motor with belt guard and controls, an automatic counter that shuts off the power after the set number of hammer drops, and a standard compaction pedestal with guide pins for centering one standard (4 inch diameter) bituminous mold at a time. The Contractor shall also provide two (2) stability compaction molds conforming to ASTM D1559 and suitable for use with the automatic bituminous compactor.

NOTE: The Soil test Model AP-800 automatic bituminous compactor and AP-166 stability compaction molds have been found suitable.

Superpave Gyrotory Compactor (For plants supplying materials contained in Table 5) conforming to the requirements of AASHTO R30, R35, M323, T312 and the Asphalt Institute Manual SP-2.

Bulk specific gravity determination equipment (AASHTO T166), and theoretical maximum specific gravity equipment (AASHTO T209).

Laboratory facilities shall be kept clean and all equipment shall be maintained in proper working condition. The Engineer shall be permitted unrestricted access to inspect the Contractor's laboratory facility and witness quality control activities, if applicable. The Engineer will advise the Contractor in writing of any noted deficiencies concerning the laboratory facility, equipment, supplies, or testing personnel and procedures. When the deficiencies are serious enough to be adversely affecting test results, the incorporation of the materials into the work shall be suspended immediately and will not be permitted to resume until the deficiencies are satisfactorily corrected.

6.2 Hauling Equipment - Shall meet MHD 460.61.

6.3 Pavers - Shall meet MHD 460.63

The paver screed may be equipped with a Longitudinal Notched - Wedge Joint paver attachment or Straight Wedge Joint paver attachment and screed mounted roller attachment. When placing WMA/HMA pavement courses at a thickness of 1.5" or greater, the notched wedge is recommended; when placing WMA/HMA pavement courses less than 1.5", the straight wedge is recommended. The notched wedge joint includes a variable notched vertical edge (the notch vertical height to be equal to the mixture's maximum aggregate size). The sloped surface of the diagonal wedge joint shall not exceed a 6:1 slope.

6.4 Rollers - Rollers of the vibratory, steel wheel, oscillatory, and pneumatic-tired type may be used. They shall be in good condition, capable of reversing direction without backlash, and operating at slow speeds to avoid displacement of the Asphalt. Static rollers shall be operated at speeds not to exceed 3 mph and vibratory rollers shall be operated at a minimum of 10 to 12 impacts/ft in vibratory mode. The number, type, and weight of rollers shall be sufficient to compact the mixture to the required density while it is still in a workable condition.

The use of equipment which causes excessive crushing of the aggregate or that which does not produce a smooth, dense and uniform WMA/HMA mat will not be permitted.

The Contractor shall exercise great caution when using vibratory rollers so as not to cause damage to buried infrastructure or adjacent infrastructure. Damage to buried or adjacent infrastructure will be the responsibility of the Contractor. The new Oscillation type rollers are acceptable for use for intermediate compaction and back rolling of WMA/HMA in the Town of Dedham.

The Contractor is encouraged, when applicable, to use a pneumatic square edge-tired compaction roller (either one or both axles) as another acceptable alternate for the Intermediate and Final rolling of hot mix in the Town of Dedham.

## 7.0 WMA/HMA CONSTRUCTION

7.1 Weather Limitations - The Asphalt shall not be placed when weather conditions of fog or rain prevail or when the pavement surface or base shows signs of free moisture (film of water). When the surface temperature of the underlying course is less than 50°F, the estimated time available for compaction shall be provided by the Contractor to the Engineer. The Engineer and the Contractor shall determine if there is an adequate amount of time available to compact the mixture. The Contractor assumes responsibility for constructing the pavement to meet compaction and specification requirements.

The Engineer will not permit work to continue when overtaken by sudden storms until the pavement surface shows no signs of free moisture. The material in transit at the time of shutdown will not be placed until the pavement surface shows no signs of free moisture, provided the mixture is within temperature limits as specified.

The construction of Asphalt concrete pavements shall terminate on November 15 and shall not be resumed prior to April 1 except as determined and directed in writing by the Engineer.

7.2 Thermometer: The Contractor will supply an approved dial type thermometer with a temperature range of 50°F to 500°F and an infrared pistol thermometer for use during WMA/HMA placement. The infrared pistol thermometer shall be Fahrenheit or Celsius selectable and conform to the following requirements:

Portable and battery operated	Accuracy of +/- 2%
Repeatability of +/- 3°C	Emissivity preset at 0.95
LCD Display to nearest 1°	Temp. Operating range of -4°F to 752°F

The thermometers will remain the property of the Contractor upon completion of the project.

7.3 Pre-Paving Conference: Prior to the placing of any WMA/HMA, a pre-paving conference (approximately 5 hours in length) shall be held to discuss and approve the paving schedule, source of WMA/HMA, job mix formula approvals, type and amount of equipment to be used, sequence of paving pattern, rate of WMA/HMA supply, all sampling, testing and reporting procedures to be used, traffic control, safety, and general continuity of the operation. Engineer's representatives, Contractor's plant, quality control and field representatives and Engineer's testing and inspection agents shall attend this meeting. All equipment used shall be approved on the project site prior to starting up each day. **It will be mandatory for the Contractor and the paving subcontractor, if**

**utilized, to attend this conference.** The Contractor will be responsible for all costs associated with additional training.

The Engineer, upon 48 hours notice, may be able to hold this conference preferably on the forecast of an inclement day.

7.4 Preparation of the Underlying Surface. Immediately before placing the Asphalt, the underlying course shall be thoroughly cleaned of all dust and debris by a self-propelled sweeper. Areas inaccessible by power sweepers shall be broom swept until the pavement surface is clean. Extra care shall be required during fall leaf fall.

Proof roll prepared base material surface, if applicable, to identify areas requiring removal and recompaction, and to provide a uniform degree of compaction over the entire pavement area.

Do not begin paving work until deficient base material areas and utility trenches have been corrected and are ready to receive paving. Paving shall not be applied until the Engineer inspects and approves the finished base.

When an existing surface or new base upon which the lower course is to be placed contains unsatisfactory irregularities, in the Engineer's judgment, such irregularities may be eliminated by an adequate placing and compaction of WMA/HMA mixture so as to furnish a surface with true contour and grade before placing any specified course of mixture.

Check all frames, covers, grates, water valve boxes and other miscellaneous castings that are located in the proposed pavement areas to ensure that all have been correctly positioned and set to the proper slope and elevation. All covers and grates shall be set flush with the required finished surface. No depressions or mounds will be permitted in the pavement to accommodate inaccuracies in the setting of castings.

For Reclaimed base, reconstruction or where new base is graded, the Contractor shall furnish, set, and maintain all line and grade stakes necessary to guide the automated grade control equipment. Where required these control stakes shall be maintained by the Contractor and used throughout the operations, from the grading of the subbase material up to and including the final layers of the pavement.

Adequate artificial lighting shall be provided during night placements. Hauling over freshly placed material shall not be permitted until the material has been compacted, as specified, and allowed to cool to an internal temperature of 140°F minimum.

Proper precautions shall be taken to prevent damage by construction operations to edges adjacent to the Asphalt. These edges may be, but are not limited to, gutters, catch basins, curbs, concrete structures, and Asphalt concrete. If damage occurs, repairs shall be made to the satisfaction of the Engineer with no additional payment.

7.5 Tack Coat: Contact surfaces of manholes, structures, vertical pavement edges, etc. shall be painted with a thin, uniform tack coat just before the material is placed against them.

Tack coat is required on all surfaces to be paved; this includes leveling, base or intermediate layers of WMA/HMA, unless the underlying WMA/HMA layer was placed during the same day. Particular attention should be made during the application that the longitudinal joint areas be treated with no bare spots. Missing areas adjacent to the longitudinal joint area will require either re-application or localized hand work application as directed by the Engineer.

Tack coat shall be applied at a residual binder amount on the pavement between 0.03 to 0.05 gallons per square yard. Use the lower application amount between new lifts and the higher application rate on milled or Portland cement surfaces. This amounts to a very thin application that needs to be carefully applied. Massachusetts uses RS-1 and CRS-1 type asphalt emulsions for tack coating. These can be applied, as an emulsion, between 0.05 to 0.08 gallons per square yard. Tack coat shall be supplied as part of the WMA/HMA operation.

Allow tack coat to dry from a brown color to a black color prior to paving.

## 7.6 WMA/HMA Production

The aggregates and the asphalt binder material shall be weighed or metered and introduced into the mixer in the amount specified by the JMF and within the allowable action limits as stated in Table 7 WMA/HMA PRODUCTION LIMITS. These limits shall be applied to the target values established in the JMF. Corrective action shall be taken by the Contractor when the calculated individual result for gradation or asphalt content falls outside the target JMF value beyond the action limit listed in Table 7. The Contractor shall take the appropriate action when results indicate the material is out of tolerance. The Contractor shall be required to suspend production when the calculated individual result for gradation falls outside the target JMF value beyond the suspension limit listed in Table 7, or when the asphalt binder content is below the minimum values stated in Table 5 or 6, whichever is applicable. The Contractor shall be required to suspend production if two points in a row fall outside the Action Limits for individual measurements or if three nonconsecutive samples fall outside the Action limits. The Contractor shall be required to suspend production if one point falls outside the Suspension Limits for individual measurements. The Contractor shall also be required to suspend production if one point falls outside the Suspension Limits for range, Table 8.

7.6.1 Plant Trials - If production is suspended, the production facility shall be required to produce material on a trial basis for testing purposes without shipment to the project. No payment will be made for material and labor employed for nonconforming plant trials. The Engineer or his representative shall pay for acceptance sampling and testing for the first set of trials necessary to determine conformance with the specification requirements. If the first set of trials does not conform to specification requirements, the Contractor

shall pay for any additional trial sampling and testing for acceptance. When trials have been approved, the plant will return to its normal operation.

Failure to stop production and make adjustments when required due to an individual test(s) not meeting the specified requirements may subject all of the mix from the stop point to be considered unacceptable.

**RAP VERIFICATION** - The Town will randomly test WMA/HMA mixtures from the production plant or storage silos to determine the quality of the PG binder. For non-modified binder mixtures, the absolute viscosity of the recovered asphalt shall be no greater than 6,000 poises at 140°F. If the absolute viscosity is greater than 6,000 poises, then a full PG binder test verification will be run for conformance to the PG grade specified. For modified asphalt binder mixtures, a full PG binder test verification will be run for conformance to the PG grade specified. Failure of the PGAB to conform to specification requirements may be cause for rejection of the Lot. Further PGAB tests may be conducted on previous Lots; all costs for the PGAB tests will be the responsibility of the Producer if the results do not meet specifications [ $T_{MAX}$  for  $G^*/\text{Sin}(d)$  DSR (RTFO Aged)] for PG 64-28 or 64-22 (whichever is applicable) recently placed.

7.7 Transporting, Placing and Finishing: WMA/HMA deliveries shall be scheduled so that placing and compacting of mixture is uniform with minimum stopping and starting of the paver.

Upon arrival, the mixture shall be placed to the full width by a Asphalt paver. It shall be struck off in a uniform layer of such depth that, when the work is completed, it shall have the required thickness and conform to the grade and contour indicated. The speed of the paver shall be regulated to eliminate pulling and tearing of the Asphalt mat. Unless otherwise permitted, placement of the mixture shall begin along the centerline of a crowned section or on the high side of areas with a one-way slope. The mixture shall be placed in consecutive adjacent strips having a minimum width of 10 feet except where edge lanes require less width to complete the area. The longitudinal joint in one course shall offset the longitudinal joint in the course immediately below by at least one (1) foot, however, the joint in the top layer shall be at the centerline of the pavement. Transverse joints in one layer shall be offset by at least two feet from transverse joints in the previous layer. The placement of the material along the longitudinal joint may be performed by setting the screed to overlap the first mat. The elevation of the screed above the surface of the first mat should be equal to the amount of roll-down expected during compaction of the new mat. The overlapped material shall be bumped by the lutes, if necessary, to optimize the density along the longitudinal joint. Under no circumstances should the overlapped material be broadcast across the mat. Excess material should be removed by hand. Transverse joints in adjacent lanes shall be offset a minimum of 10 feet.

On areas where irregularities or unavoidable obstacles make the use of mechanical spreading and finishing equipment impractical, the mixture may be spread and luted by hand tools. When hand spreading is permitted, the mixture shall be distributed into place

by means of hot shovels and spread with lutes in a loose layer of uniform density and correct depth. The use of rakes to spread the Asphalt shall not be permitted. Loads shall not be dumped any faster than they can be properly handled by the shovelers and the shovelers shall not distribute the dumped load any faster than it can properly be handled by the luters. The luting shall be carefully and skillfully done to avoid segregation and so that, after the first passage of the roller over the luted mixture, no back patching will be necessary. Compaction must immediately follow hand spreading such that specification density is achieved while the mixture temperature is above the manufacturers recommended compaction temperature for the performance graded binder.

The mixtures shall be placed and compacted only at such times as to permit the proper inspection and checking by the Engineer.

The mixtures shall only be placed in the work when they can be efficiently and satisfactorily placed, compacted, smoothed, and made uniform in accordance with these specifications. Unless otherwise permitted by the Engineer for special particular conditions, only machine methods of placing shall be used.

No mixture shall be placed unless the breakdown and intermediate rolling can be completed by the time the material has cooled to 150°F, or that minimum compaction temperature specified by the binder manufacturer and provided that the density and uniformity of the completed pavement attains specification compliance.

No traffic of any kind shall be permitted on the WMA/HMA intermediate or WMA/HMA base when dirt or any other foreign substance may be tracked thereon.

Immediately after any course is screeded and before roller compaction is started, the surface shall be checked, any irregularities adjusted, any accumulation from the screed removed by rake or lute, and all fat spots in any course removed and replaced with satisfactory materials. Irregularities in alignment and grade along outside edges shall be corrected by the addition or removal of mixture before the edges are rolled. Indiscriminate casting of mix on the new screeded surface, where irregularities are not evident, shall not be permitted.

All hot mix shall be placed and compacted in such a manner as to ensure a continuous bond between the tacked hot mix pavement surfaces and obtain the required density.

7.7.1 Second Control Strip Requirement - If it is determined, during the performance of the contract, that the pavement does not conform to the surface tolerance, density and uniformity requirements, the Engineer may order the Contractor to cease all operations and construct an WMA/HMA CONTROL SECTION consisting of a sufficient quantity of surface course mixture. The Contractor shall construct a control section as directed by the Engineer either: a minimum of 100 feet long by 12 feet wide, or a minimum of 50 feet long by a minimum of 24 feet wide depending upon the problem. A control section may be

required each time a change is made in the Job Mix Formula, sources of supply or paving and rolling equipment.

The mixture shall be prepared, placed, and compacted in accordance with this specification. When the control section pavement has cooled sufficiently, a total of six (6) samples of the finished pavement shall be taken and tested in accordance with the requirements of Section 5.0.

If the tests by the Engineer indicate that pavement does not conform to specification requirements, necessary adjustment to plant operation and placement/rolling procedures shall be made.

Where the average density of the core samples does not conform to specification requirements, the pavement shall be removed at no cost to the Engineer. No payment will be made for material and labor employed, either in placement or removal of the nonconforming control section.

The second control strip may be removed at the direction and at no cost to the Engineer if the test result of any one mat core density falls below 90% of theoretical maximum laboratory density and/or any one longitudinal joint density falls below 88% of theoretical maximum laboratory density.

The Contractor shall not be permitted to place surface course pavement until a control section is approved by the Engineer.

7.8 Joints: The formation of all joints shall be made in such a manner as to ensure a continuous bond between the courses and obtain the required density. All joints shall have the same texture as other sections of the course and meet the requirements for smoothness and grade. When abutting a previously placed lane, the longitudinal joint should be rolled first followed by the regular rolling procedure.

7.8.1 Transverse Joints - The roller shall not pass over the unprotected end of the freshly laid mixture except when necessary to form a transverse joint. When necessary to form a transverse joint, it shall be made by means of placing a bulkhead or by temporarily tapering the course, in which case the edge shall be cut back to its full depth and width on a straight line to expose a vertical face. In both methods, all contact surfaces shall be given a coat of hot-pour rubberized asphalt sealer before placing any fresh mixture against the joint.

7.8.2 Longitudinal Joints - All longitudinal joints shall be constructed with the first paver pass in a neat straight line. Deviation from trueness will negate the ability to form a properly compacted longitudinal joint.

The paver screed may be equipped with a Longitudinal Notched - Wedge Joint or Straight Wedge Joint paver attachment and screed mounted roller attachment when placing WMA/HMA pavement courses. Use the Notched Wedge Joint for



thicknesses of 1.5" or greater and use the Straight Wedge Joint for thicknesses less than 1.5". The notched wedge joint shall include a variable notched vertical edge (the notch vertical height to be equal to the mixture's maximum aggregate size). The sloped surface of the diagonal wedge joint shall not exceed a 6:1 slope. Prior to placing the adjacent paver pass for sloped joints, all joint contact surfaces shall be given a tack coat prior to placing any fresh mixture against the joint.

Vertical butt joints which are not constructed straight, or are not constructed with an edge restraining device (either a commercial paver screed attachment or by dropping the end gate down to the surface), or are damaged or otherwise defective shall be cut back 3 inches to expose a clean, sound surface for the full depth of the course. All contact surfaces shall be given a coat of hot-pour rubberized asphalt sealer prior to placing any fresh mixture against the joint.

7.8.3 Longitudinal and transverse joints shall have an in-place density when measured by the average of three, six (6") inch cores between 90% to 98% of maximum theoretical.

7.9 Compaction of WMA/HMA Mixture After Placing - The mixture shall be thoroughly and uniformly compacted by rolling. The surface shall be compacted as soon as possible when the mixture has attained sufficient stability so that the rolling does not cause undue displacement, cracking or shoving. The sequence of rolling operations and the type of rollers used shall be at the discretion of the Contractor. Rolling shall be initiated with the drive roll or wheel towards the paving machine. When rolling on steep grades, the previous procedure may need to be altered.

The speed of the roller shall, at all times, be sufficiently slow and of uniform speed to avoid displacement of the hot mixture and be effective in compaction. Any displacement occurring as a result of reversing the direction of the roller, or from any other cause, shall be corrected at once.

Sufficient rollers shall be furnished to handle the output of the plant. Rolling shall continue until the surface is of uniform texture, true to grade and cross section, and the required field density is obtained. The number of rollers and passes required shall be governed by the compaction results; however, at least two rollers shall be provided for each paver employed on the paving operation. The Town of Dedham is encouraging the use of pneumatic or oscillation rollers. If one of the selected rollers is pneumatic, it shall be equipped with the European square edge tires. This will allow the pneumatic roller to handle both the intermediate compaction as well as the back rolling responsibilities on two-roller trains. An alternate to a full pneumatic European tired roller would be a combination 10-ton steel vibratory with large pneumatic square edge rear wheels. An acceptable alternative to the vibratory or pneumatic tired rollers would be the "Hamm" Oscillatory roller. Each roller shall be operated by a competent, experienced roller operator and shall be kept in as nearly continuous operation as practicable while work is underway. A plate shall be attached to each roller showing the ballasted and unballasted weight per length-width of tread.

To prevent adhesion of the mixture to the steel roller, the drums or shall be kept properly moistened, cocoa mats kept clean and scrapers used, but excessive water will not be permitted. Pneumatic rollers shall be operated on adjacent pavement surfaces to get the tires warm to hot from friction, then moved to the fresh mat.

In areas not accessible to the roller, the mixture shall be thoroughly compacted with hand tampers and vibratory plate compactors.

Any mixture that becomes loose and broken, mixed with dirt, contains check-cracking, or in any way defective shall be removed and replaced with fresh hot mixture and immediately compacted to conform to the surrounding area. This work shall be done at the Contractor's expense. Skin patching shall not be allowed.

Along any adjoining edge such as curb, gutter or an adjoining pavement, and after the WMA/HMA is placed by the paver, just enough of the hot WMA/HMA shall be placed by hand method to fill any space left open. These joints shall be properly 'set up' with the back of a lute at the proper height and level to receive the maximum compaction. Any areas where the rollers cannot access shall be hand tamped or plate compacted.

7.9.1 Shaping Edges - While the surface is being compacted and finished, the Contractor shall carefully trim the outside edges of the pavement to the proper alignment. Edges so formed shall be beveled while still hot with the back of a lute or smoothing iron and thoroughly compacted by tampers or by other satisfactory methods.

7.10 Surface Smoothness - The finished surfaces of the pavement shall be uniform in appearance, free from irregularities in contour and texture and shall present a smooth-riding surface. Smoothness evaluation applies to all Asphalt concrete roadways receiving 1.5" or more in plan (compacted) thickness of WMA/HMA pavement.

Tests for conformity with the specified crown and grade shall be made by the Contractor immediately after initial compaction. Any variation shall be corrected by the removal or addition of materials and by continuous rolling.

The finished surface of the pavement, when measured with a 10-foot straightedge, shall not vary more than 1/4 inch for the surface course and 3/8 inch for the intermediate course measured perpendicular and parallel to the centerline. If, in the opinion of the Engineer, the surface visually appears wavy, but meets the surface tolerance test with the 10-foot straightedge, the Engineer reserves the right to additionally test with the use of Inertial Profile Equipment which records cumulative vertical deviations per unit length using a statistic called International Roughness Index (IRI). Town of Dedham street upset limit for IRI is set at 135 in/mile using similar equipment that MHD specifies in their Quality Assurance WMA/HMA projects.

After the completion of final rolling, the smoothness of the course shall again be tested; humps or depressions exceeding the specified tolerances shall be immediately corrected by removing the defective work and replacing with new material, as directed by the Engineer. This shall be done at the Contractor's expense.

Skin patching will not be permitted.

When profile corrections are required, the Contractor shall use one or more of the following corrective methods:

- a. Removing and replacing the entire pavement thickness;
- b. Diamond grinding or micro milling;
- c. Overlaying (not patching) with the specified surface course;
- d. Removing the surface by milling and applying a lift(s) of the specified course(s);
- e. Use of other methods that will provide the desired results;

The corrective method(s) chosen by the Contractor shall be performed at the Contractor's expense, including all necessary equipment and traffic control. Areas of removal and replacement shall be removed the full width of the lane. The removal areas shall begin and end with a transverse butt joint which shall be constructed with a transverse saw cut perpendicular to the centerline. Replacement materials shall be placed in sufficient quantity so the finished surface will conform to grade and smoothness requirements. The corrective area shall conform to all material and density specification requirements. When the corrective work consists of an overlay, the overlay shall cover the full width of the pavement including shoulders. The area overlaid shall begin and end with a transverse butt joint which shall be constructed with a transverse saw cut and asphalt removal. All materials shall meet contract requirements. The overlay shall be placed so the finished surface will conform to grade and smoothness requirements. The overlaid area shall be compacted to the specified density.

The Engineer shall retest any sections where corrections were made to verify that the corrections produced a surface that conforms to the grade and smoothness requirements

7.11 Uniformity- The WMA/HMA mat shall be smooth, dense, and uniform. Uniformity is generally affected by Thermal and/or Aggregate segregation.

If segregation is evident and discernable by either the Contractor or the Engineer, the Contractor shall immediately cease production and take steps to correct and eliminate the cause(s) of the segregation to the satisfaction of the Engineer.

The Contractor shall review all potential causes of segregation as it relates to its operation, including but not limited to WMA/HMA Plant issues, loading and transportation issues, placement issues, thermal segregation, and hand work. The Contractor shall employ additional investigation methods and make the necessary changes in their operation such that segregation is eliminated and mat uniformity is acceptable.

7.12 Thickness - The thickness requirements contained herein shall apply only when each pavement layer is specified to be a uniform compacted thickness of 1 inch or greater. Thickness shall be evaluated for acceptance by the Engineer to the requirements shown on the plans. Measurements of thickness may be checked periodically by the Contractor in following their QC system for field operations. Measurements of thickness for acceptance shall be made by the Engineer using four-inch minimum diameter pavement cores removed also for subsequent density measurement.

The finished surfaces of each WMA/HMA pavement course shall not vary from that specified or cross sections shown on the contract drawings by more than one-quarter (1/4) of an inch. The Contractor shall correct pavement areas varying in excess of this amount by removing and replacing the defective work or as ordered by the Engineer. Skin patching will not be permitted.

7.13 Grade - The finished surface of the pavement shall not vary from the gradeline elevations as shown on the plans by more than 1/2 inch. The Contractor shall remove deficient areas and replace with new material. Sufficient material shall be removed to allow at least 1.5 inches of Asphalt to be placed. Skin patching for correcting low areas shall not be permitted. High points may be ground off.

7.14 Leveling Course - Any WMA/HMA used for truing and leveling shall meet the requirements of the mix design methods and the requirements of the TABLE 7 or TABLE 5 and 6 specifications for the applicable mixtures. Leveling courses shall not be subject to density requirements. The thickness of the Leveling Course shall be measured off the interface with the existing milled or un-milled pavement surface. The leveling course shall be compacted with the same effort used to achieve placement and density of the test section. The truing and leveling course shall not exceed a nominal thickness of 1.5 inches.

#### 7.15 Opening to Traffic

No vehicular traffic or loads shall be permitted on the newly completed pavement until adequate stability has been attained and the material has cooled sufficiently to an internal temperature of 140°F or less. If the climatic or other conditions warrant, or if the PGAB manufacturer recommends, the period of time before opening to traffic may be extended at the discretion of the Engineer.

7.16 Contractor Quality Control of WMA/HMA Pavement - Contractor Quality Control shall include production and placement Inspection and Testing and shall apply to all tons used in the Town of Dedham road program.

The Contractor shall be prepared to discuss and present, at the pre-paving conference, their understanding of quality control for this contract.

##### 7.16.1 Control Charts

Contractor may develop production control charts and post for visual reference in the testing laboratory. The control charts should identify the project number, the contract item number, the test number, each test parameter, the Action and Suspension Limits applicable to each test parameter, and the production test results. If the project data during production indicates a problem and the Contractor is not taking satisfactory corrective action, then the Engineer may suspend production or acceptance of the material, in accordance with these specifications.

- A. Individual Measurements: Control charts for individual measurements may be established to indicate production quality control within given tolerances for aggregate gradation and asphalt binder content. The control charts will use the JMF target values as the indicator of central tendency for the following test parameters with associated Action and Suspension Limits:

**TABLE 7 WMA/HMA PRODUCTION LIMITS FOR INDIVIDUAL MEASUREMENTS**

<u>Sieve Size</u>	<u>Action</u>	<u>Suspension</u>
1-1/2" (37.5mm)	0%	0%
1" (25.0 mm)	±6%	±9%
3/4" (19.0 mm)	±6%	±9%
1/2" (12.5 mm)	±6%	±9%
3/8" (9.5 mm)	±6%	±9%
#4 (4.75 mm)	±6%	±9%
#8 (2.36 mm)	±5%	±7.5%
#16 (1.18 mm)	n/a	n/a
#30 (0.600 mm)	n/a	n/a
#50 (0.300 mm)	n/a	n/a
#100 (0.150 mm)	n/a	n/a
#200 (0.075 mm)	±2%	±3%
Asphalt Binder Content	±0.4%	±0.70%
Design Air Voids (4.0%)	±1%	±1.7%

When evaluating the production limits, the sieve sizes above the maximum size aggregate should be deleted from the Individual Measurements Chart and the maximum aggregate sieve size Action and Suspension Limits should be changed to 0%.

Range. Control charts for range may be established to indicate production variability for the test parameters and Suspension Limits listed below. The range may be computed as the difference between the high and low test results per lot for each control parameter. The Suspension Limits specified below are based on a sample size of n = 2. Should the Contractor elect to perform more than two tests per lot, the Suspension Limits shall be adjusted by multiplying the Suspension Limit by 1.18 for n = 3 and by 1.27 for n = 4.

<b>Table 8 CONTROL CHART LIMITS BASED ON RANGE</b>	
(Based on n = 2)	
Sieve	Suspension Limit
1-1/2" (37.5 mm)	11 percent
1" (25.0 mm)	11 percent
3/4" (19.0 mm)	11 percent
1/2" (12.5 mm)	11 percent
3/8" (9.5 mm)	11 percent
#4 (4.75 mm)	11 percent
#8 (2.36 mm)	10 percent

#16 (1.18 mm)	n/a
#50 (0.30 mm)	n/a
#200 (0.075 mm)	3.5 percent
Asphalt Binder Content	0.8 percent
Design Air Void Content	2.0 percent

### **CORRECTIVE ACTION**

The Contractor's Quality Control system shall include an appropriate action to be taken when the process is believed to be out of tolerance. The Contractor should review the control charts on a continuous basis making adjustments to the process when necessary to keep the product consistent. As a minimum, a process shall be deemed out of control and production stopped and corrective action taken, if:

Design Air Voids falls outside the Suspension Limit line for its individual measurement or range as indicated in Table 7 or Table 8; or

Design Air Voids and two or more points fall outside the Action Limit line for individual measurements or range as indicated in Table 7 or Table 8 ; or

Design Air Voids fall outside the Action Limit and one point falls outside the Suspension Limit for individual measurements or range as indicated in Table 7 or Table 8; or

Three points in a row fall outside the Action Limit line for individual measurements as indicated in Table 7.

Three nonconsecutive samples fall outside the Action Limit line for individual measurements as indicated in Table 7.

Two consecutive streets or two consecutive 1,000 ton lots of material tested for mat density or longitudinal joint density falls below the threshold density for 100% adjustment, as noted in Table 9 and Table 10.

The average of the last five streets or five 1,000 ton lots of material tested for mat density or longitudinal joint density falls below the threshold density for 100% adjustment, as noted in Table 9 and Table 10.

Acceptance testing requirements are the responsibility of the Engineer.

### **8.00 Quality Acceptance of WMA/HMA**

All acceptance sampling and testing necessary to determine conformance with the requirements specified in this section will be performed by the Engineer at no cost to the Contractor, unless otherwise stated herein. Testing organizations performing these tests shall meet the requirements of ASTM D 3666. All equipment in Contractor furnished laboratories shall be calibrated and verified by a testing organization prior to the start of operations. Such verification/certification

shall be furnished to the Engineer prior to production. Engineer's testing personnel shall be certified by the New England Transportation Technician Certification Program (NETTCP). This function does not relieve the Contractor from performing their daily quality control tasks as part of their normal operating business.

The Engineer or their agent shall have access at any time to all parts of the producing plant for:

- A) Inspection of the condition and operations of the yard, plant and laboratory.
- B) Confirmation of the adequacy of equipment in use.
- C) Verification of the character and proportions of the mixture.
- D) Determination of temperatures being maintained in the preparation of the mixtures.
- E) Inspection of incidental related procedures.

Samples of all material including compacted specimens and certified copies of all reports and printouts shall be made available to the Engineer or its agent as often as requested including: asphalt binder; virgin aggregates; modifiers, loose and compacted mixture specimens; and combined aggregate samples.

8.10 Plant-Produced Material. Plant-produced material shall be sampled and tested for VMA, gradation, asphalt binder content, and air voids (Marshall or Superpave at  $N_{design}$ ), on a lot basis. The Engineer's testing personnel shall be certified by the New England Transportation Technician Certification Program (NETTCP), as WMA/HMA Plant Technicians. Sampling shall be from material deposited into trucks at the plant or from trucks at the job site. A lot will consist of:

- one day's production

Where more than one plant is simultaneously producing material for, the job, the lot sizes shall apply separately for each plant.

8.1.1 - Sampling - Sufficient material for analysis and preparation of test specimens will be sampled by the Engineer on a random basis, in accordance with the procedures contained in ASTM D 3665. A minimum of one set of laboratory compacted specimens will be prepared for each lot in accordance with AASHTO T312, at the number of gyrations required by Table 5 herein (for Superpave only), or in accordance with Marshall design criteria, Table 6. Each set of laboratory compacted specimens will consist of two test portions prepared from the same field sample.

The sample of Asphalt may be put in a covered metal tin and placed in an oven for not more than 30 minutes to maintain the heat. The compaction temperature of the specimens should be as specified in the JMF.



In addition to the Asphalt samples, the Contractor shall take one, one-quart sample of the PG binder used to produce the Asphalt at the start of the work. The PG sample shall be turned over to the Engineer on the first day of project production.

#### 8.1.2 - Testing

- A. Bulk Specific Gravity - Sample specimens shall be tested for bulk specific gravity in accordance with AASHTO T166 or T275, whichever is applicable, for use in computing air voids and density. Air voids shall be computed in accordance with AASHTO T269.
- B. Gradation and Asphalt Binder Content - The gradation and asphalt binder content of the mixture shall be measured for each lot in accordance with the following:
  - (1) Asphalt Binder Content - A minimum of three (3) extraction tests shall be performed in accordance with AASHTO T164 or AASHTO T308 for determination of asphalt content. The weight of ash portion of the extraction test, as described in AASHTO T164, shall be determined as part of the first extraction test performed at the beginning of plant production; and as part of every tenth extraction test performed thereafter, for the duration of plant production. The last weight of ash value obtained shall be used in the calculation of the asphalt content for the mixture. If utilizing AASHTO T308 for asphalt content determination, the calibration process and calibration factor, as described in AASHTO T308, shall be determined as stated, prior to acceptance testing. A verification shall be performed as part of every twentieth test performed thereafter or when changes in the mix are apparent.
  - (2) Gradation - Aggregate gradations shall be determined from mechanical analysis of extracted aggregate in accordance with AASHTO T 30 and AASHTO T27 (Dry Sieve). When asphalt content is determined by the nuclear method, aggregate gradation shall be determined from hot bin samples on batch plants, or from the cold feed on drum mix or continuous mix plants, and tested in accordance with AASHTO T27 (dry sieve) using actual batch weights to determine the combined aggregate gradation of the mixture.
- C. The Dust-to-Effective Asphalt ratio shall be determined once for each subplot from the mechanical analysis of extracted aggregate and the asphalt binder content. The Dust-to-Effective Asphalt ratio shall be determined by the Engineer in accordance with AASHTO PP28-02.
- D. The Theoretical Maximum Specific Gravity of the mixture shall be measured for each lot in accordance with AASHTO T209, Type C, D, or E container. Samples shall be taken on a random basis in accordance with ASTM D 3665. The value

used in the field placed void computations shall be the average of the maximum specific gravity measurements for the street paved.

- E. Temperatures. Temperatures shall be checked, at least three times per lot, at necessary locations to determine the temperatures of the dryer, the asphalt binder in the storage tank, the mixture at the plant, and the mixture at the job site.
- F. VMA and air voids, for each plant field sample, will be determined by the Engineer in accordance with the applicable AASHTO test method. The VMA, and air voids for each lot shall be computed by averaging the results of the two test specimens representing that lot.

8.1.3 Acceptance of Plant Produced WMA/HMA - Acceptance of plant produced WMA/HMA material will be based upon plant air voids, Marshall stability and flow (if applicable), VMA, gradation, asphalt binder content, and temperature, and shall be determined by the Engineer in accordance with these specifications.

8.2 Field Placed WMA/HMA Material - WMA/HMA material placed in the field shall be tested for both joint and mat density on a completed street or public facility basis. The Engineer may conduct any necessary testing to monitor that the specified density, uniformity and smoothness is being achieved. A properly correlated nuclear or non-nuclear gauge may be used to monitor the pavement density in accordance with ASTM D2950.

8.2.1 Sampling - Density gauges (nuclear or non-nuclear) may be used by the Engineer to determine density of the WMA/HMA mat and/or longitudinal joints in accordance with the calibration and correlation procedures outlined in this specification. Cores of the WMA/HMA material shall be minimized and only taken at the direction of the Engineer and approval of the Town.

Mat and longitudinal joint density tests will be located by the Engineer on a stratified random sampling basis for each street or facility paved within three days of construction. The length of the longitudinal paving joint will be divided into sub-lots for sampling and testing purposes. If more than one longitudinal joint is formed on a street, then the random sample length will be the total lineal feet of longitudinal joint placed. A mat and longitudinal joint test will be taken by the Engineer randomly from each these sub-lot intervals. Sub-lots will be determined on the basis of five (5) sub-lots per one thousand (1,000) tons of material placed or a minimum of three (3) sub-lots from each street or facility paved. Sampling and testing for density will be conducted in the following manner:

Paving courses will tested with the density gauge (for correlation), then sampled by coring the mat and longitudinal joint using a 6 inch diameter wet-core bit specifically designed for cutting pavement. The cores will be tested for density and thickness.

When sampling of the longitudinal joint for density determinations by coring, the core will be taken on the joint, not adjacent to the longitudinal paving joint.

A test for intermediate course density and a test for surface course density will be obtained from each sub-lot segment. The total width of the paved surface (curb to curb) will be determined at the longitudinal sub-lot location to sample and test for mat density. A transverse off-set distance from the centerline of the roadway will be established for mat density sampling and testing. The location, either right or left of centerline, will be based on whether a random number is “odd or even” (odd=left; even=right). When the off-set location is within 2 foot of the pavement edge, curb, catch basin or structure, or 1 foot off a longitudinal joint, or 10 foot off a transverse joint, the sample shall be relocated.

For all nuclear density gauge test locations, two 60-second readings will be taken with the gauge turned 180 degrees for each increment. The average of the two readings will be reported as the density value for each location.

For non-nuclear density gauge test locations, five (5) increments will be used, moving the gauge six inches after each reading in a square pattern, taking one reading in each corner and one in the center. The average if the five readings will be reported as the density value for each location.

The testing of the longitudinal joint for density determinations will be made by placing the density gauge first on one side adjacent to the longitudinal paving joint, then placed on the other side of the longitudinal paving joint, then the results averaged. Each placement of the gauge will result in the averaging of two test increments on each side of the joint with the gauge turned 180 degrees for each increment.

If the results of the average density gauge readings for a street, pavement facility, or paving day are below the threshold for 100% adjustment as indicated in Table 9 or Table 10, pavement cores will be removed as per this specification, and used for determining the actual pavement density.

In the event that a new density gauge must be correlated for this project, cores will be taken from the mat and longitudinal joint representing the test locations. If “re-correlation” is necessary, take four density tests at quarter points around each of five previously cored and tested locations; making sure that the side of the gauge is at the edge of the patched core location and firmly seated. For nuclear density gauges, each test must be the average of two test increments turning the gauge 180 degrees.

For non-nuclear density gauges, five (5) increments will be used, moving the gauge six inches after each reading in a square pattern, taking one reading in each corner and one in the center. The average if the five readings will be reported as the density value for each location.

All core samples shall be neatly cut with a core drill and water cooled bit where the cutting edge of the core drill bit shall be of hardened steel or other suitable material with diamond chips embedded in the metal cutting edge. The minimum diameter of the sample shall be 6 inches. Samples that are clearly defective, as a result of sampling, shall be discarded and another sample taken. The Engineer or the Owner’s agent shall furnish all tools, labor, and materials for cutting samples and filling the cored pavement. Cored holes shall be filled by the Engineer and within one day after sampling.

Pavement cores may be used to determine the average percent density and thickness of WMA/HMA courses; nuclear or non-nuclear density gauge readings may be used for density testing of WMA/HMA courses. The average density will be used to determine the percent payment. Resampling of the pavement shall be in accordance with applicable provisions of the NETTCP Quality Assurance Technologist Manual, latest edition.

If the Contractor is concerned about the test results obtained by the Engineer, the Contractor may request that random core samples be obtained and tested to supplement (not replace) the original core data. The coring, patching and testing of the additional samples will be the responsibility of the Contractor. Cores for the mat and/or longitudinal joint density tests will be located by the Engineer and witnessed by the Contractor. Cores locations will be based on a new stratified random sampling plan for each street or facility paved in accordance with the procedures stated above. Upon approval of the coring operation, the Contractor will notify the Engineer 48 hours in advance of the cores being taken such that the Engineer can witness the sampling. The additional cores must be tested by a certified WMA/HMA plant technician in the presence of the Engineer or his designated representative.

Only one (1) set of additional mat and/or longitudinal joint cores will be allowed on a street or lot.

8.2.2 Testing - The bulk specific gravity of each cored sample will be measured by the Engineer in accordance with AASHTO T166 or T275, whichever is applicable. The theoretical maximum specific gravity shall be the average maximum specific gravity for the day's production in accordance with the plant-produced material section. The theoretical value used for the percent density of the core samples shall be the average of the measurements for maximum specific gravity for the day's production. The percent density of each sample will be determined in accordance with AASHTO T269, using the bulk specific gravity of each sample and the average theoretical maximum specific gravity. Retesting of pavement shall be in accordance with applicable provisions of the NETTCP Quality Assurance Technologist Manual, latest edition.

- A. Mat Density. Core locations will be determined by the Engineer on a random basis in accordance with procedures contained in ASTM D 3665. Cores shall not be taken closer than 1 foot from a longitudinal joint and 10 feet from a transverse joint.
- B. Joint Density. Three (3) six inch diameter cores of finished longitudinal joint will be taken by the Engineer or the Engineer's representative from each street, public facility, or paving day. Core locations will be determined by the Engineer on a random basis over the joint, not adjacent to the joint.

8.2.3 Adjustment Pay Schedule for Mat Density - The pay factor based on the density adjustment schedule will be applied to the bid price per ton after any monthly price adjustments for liquid asphalt and fuel for compacted mixtures greater than or equal to 1-1/2 inches thickness as shown in the contract award.

**Table 9.**  
**ASPHALT MAT DENSITY**  
**Adjustment Schedule**

Average Percent of Maximum Density (minimum 3 samples)	Percent Payment
100.0 - 98.1	98
98.0 - 95.0	102
94.9 - 92.0	100
91.9 - 89.0	90
88.9 - 87.0	75
86.9 or less	50% or rejection

8.2.4 Adjustment Pay Schedule for Longitudinal Joint Density - The pay factor based on the joint density adjustment schedule will be applied to the bid price per ton after any monthly price adjustments for liquid asphalt and fuel for compacted mixtures greater than or equal to 1 1/2 inches thickness as shown in the contract award.

**Table 10.**  
**ASPHALT LONGITUDINAL-JOINT DENSITY**  
**Adjustment Schedule**

Average Percent of Maximum Density (minimum 3 samples)	Percent Payment
100.0 - 98.1	98
98.0 - 95.0	102
94.9 - 90.0	100
89.9 - 89.0	90
88.9 - 88.0	80
87.9 - 87.0	70
86.9 or less	50% or rejection

The total Asphalt adjustment will be based on the weighted sum as follows:

$$.60 \text{ Mat Adjustment} + .40 \text{ LJ Adjustment} = \text{Total WMA/HMA Adjustment}$$

When the construction of the pavement does not include the construction of a longitudinal joint, the payment adjustment will be based on Table 9 only, no weighted sum will be calculated.

**Price adjustments to the contract bid price related to monthly price adjustments for liquid asphalt, diesel fuel and gasoline will be performed first, followed by WMA/HMA adjustments related to mat and joint density.**

8.2.5 - Rejection of Inferior WMA/HMA The Engineer may at any time, notwithstanding previous plant acceptance, reject and require the Contractor to dispose of any batch of Asphalt which is rendered unfit for use due to contamination, segregation, incomplete coating of aggregate, or improper mix temperature. Such rejection may be based on only visual inspection or temperature measurements. Similarly, the Engineer may at any time, notwithstanding field acceptance for mat density, reject and require the Contractor to correct any WMA/HMA pavement that was placed with unacceptable mat uniformity or paving joints due to low density, segregation, improper elevation, or tearing. In the event of such rejection, the Contractor and Engineer may take random split samples of the area(s) in question in the presence of the Engineer, and if it can demonstrate in the laboratory, in the presence of the Engineer, that such material/pavement was erroneously rejected, payment will be made for the material at the contract unit price.

8.3 Rounding - Numbers used in all calculations shall be carried to the correct significant figures and rounded as follows:

- A. When the first digit after those you want to drop is 4 or less, that digit and all others to the right are dropped. Ex. 62.9437 to 3 significant digits = 62.9
- B. When the first digit after those you want to retain is 5 or greater, that and all others to the right are dropped and the last digit retained is increased by one. Ex. 1.955234 to 3 significant digits = 1.96.
- C. All Intermediate calculations should not be rounded and shall be reported to two more significant figures than the least number of significant figures in the data values.
- D. Test Standards and technical look-up tables serve as first priority over these rounding rules.

8.4 Outliers - Due to the extremely low probability of an outlier occurring in a small number of samples representing the Lot, no outliers will be considered. If a result is suspect, it would be prudent to take the time to investigate the sampling, testing, equipment calibration, production and construction operation to identify the cause of the suspect reading.

## 9.0 Measurement

9.1 Method of Measurement - The quantity of Asphalt to be paid for shall be the measured by the ton complete in place. The quantity of each truck load shall be obtained from printed tickets indicating the recorded batch weights or certified truck scale weights that have been properly countersigned by an authorized representative of the Engineer at the time of delivery. WMA/HMA quantities shall be verified by the Engineer using WMA/HMA yield calculations which will include the in-place bulk specific gravity and actual area and nominal depth for the mixture placed.

## 10.0 PAYMENT

10.1 Basis of Payment - Payment shall be made at the contract unit prices per ton complete in place with any applicable adjustments. This payment shall be full compensation for furnishing and placing all quality Asphalt materials, including installation of paver placed berm, cutting of



Asphalt Berm, Type A – Modified will be measured for payment by the linear foot, complete in place, along the gutter line when placed with an approved extrusion machine.

Asphalt Berm, Type A – Modified placed by an Asphalt paving machine as part of the installation HMA Roadway pavement shall not be paid under this item, but shall be considered incidental to the appropriate Asphalt Roadway Pavement pay item.

Payment

Payment for work under this item shall be made at the Contract unit bid price per linear foot complete in place and shall include full compensation for furnishing all labor, materials and equipment, and any other incidental items necessary for the satisfactory completion of this work as specified.

**ITEM 472. ASPHALT FOR MISCELLANEOUS WORK TON**

Work under this item shall conform to the relevant provisions of Sections 460, 470, 472, and 701 of the Massachusetts Highway Department 2021 Standard Specifications for Highways & Bridges, the latest supplements and addendum thereto, and the following:

Asphalt for miscellaneous work shall be used to provide temporary access and egress to those properties abutting the work area as determined by the Town. It shall also be used for areas, which require Asphalt for patching for temporary transition areas when and where the Town specifies such areas. It shall also be used for permanent patching between new concrete sidewalk and Asphalt pavement or bituminous concrete aprons were no concrete sidewalks are proposed.

The Contractor is advised that this material shall be spread primarily by hand methods. Asphalt for miscellaneous work shall be placed only upon the direction of the Town.

All excavations encountered during the preparation to the use of Asphalt under this item shall be included in the bid price per ton.

Payment

Payment for work under this item shall be made at the Contract unit bid price per ton and shall include full compensation for furnishing all labor, materials and equipment, excavations to the depth required to complete work, tacking, joint sealing, and any other incidental items necessary for the satisfactory completion of this work as specified.

**ITEM 482.3 SAWING ASPHALT PAVEMENT**

**LINEAR FOOT**



Work under this item shall conform to the relevant provisions Section 120 of the Massachusetts Highway Department 2021 Standard Specifications for Highways & Bridges, the latest supplements and addendum thereto, and the following:

All edges of excavations made in existing pavements and sidewalks shall be squared by saw cutting with power driven tools to provide a neat, clean edge for joining new pavement or sidewalks.

In areas where an existing sidewalk abuts a building, wall or storefront and is to be reconstructed, the existing sidewalk shall be saw cut a minimum of six (6) inches from the building wall or storefront unless otherwise directed by the Town.

Saw cut surfaces in roadway areas shall be treated as specified in accordance with Subsection 460.65 of the Standard Specifications, as amended, or as directed by the Town.

Saw cutting required for the installation of traffic signal conduit shall be included as part of the respective conduit item and shall not be included for payment under this item.

Payment

Payment for work under this item shall be made at the Contract unit bid price per linear foot and shall include full compensation for furnishing all labor, materials and equipment, and any other incidental items necessary for the satisfactory completion of this work as specified.

**ITEM 482.34                      SAWING CEMENT CONCRETE                      LINEAR FOOT**

Work under this item shall conform to the relevant provisions of Sections 120 of the Massachusetts Highway Department 2021 Standard Specifications for Highways & Bridges, the latest supplements and addendum thereto, and the following:

All edges of excavations made in cement concrete shall be squared by saw cutting with power driven tools to provide a neat, clean edge for joining cement concrete. The Town prior to commencing work shall approve the sawcut equipment.

In areas where an existing sidewalk abuts a building, wall or storefront and is to be reconstructed, the existing sidewalk shall be saw cut a minimum of six (6) inches from the building wall or storefront unless otherwise directed by the Town.

Payment

Payment for work under this item shall be made at the Contract unit bid price per linear foot and shall include full compensation for furnishing all labor, materials and equipment, and any other incidental items necessary for the satisfactory completion of this work

<b>ITEM 506.</b>	<b>GRANITE CURB TYPE VB-STRAIGHT</b>	<b>LINEAR FOOT</b>
<b>ITEM 506.1</b>	<b>GRANITE CURB TYPE VB-CURVED</b>	<b>LINEAR FOOT</b>
<b>ITEM 509.</b>	<b>GRANITE TRANS. CURB FOR WCR STRAIGHT</b>	<b>LINEAR FOOT</b>
<b>ITEM 509.1</b>	<b>GRANITE TRANS. CURB FOR WCR - CURVED</b>	<b>LINEAR FOOT</b>
<b>ITEM 580.</b>	<b>CURB REMOVED AND RESET</b>	<b>LINEAR FOOT</b>
<b>ITEM 581.</b>	<b>CURB INLET REMOVED &amp; RESET</b>	<b>EACH</b>
<b>ITEM 590.</b>	<b>CURB REMOVED &amp; STACKED</b>	<b>LINEAR FOOT</b>

Work under these items shall conform to the relevant provisions of Section 500 of the Massachusetts Highway Department 2021 Standard Specifications for Highways & Bridges, the latest supplements and addendum thereto, and the following:

It is intended that all existing curbing removed during construction be reset as directed by the Town. All straight curbing not reused, and all curved curbing of a different radius than proposed, shall be transported and neatly stacked at locations as specified by the Director of Public Works.

Any curbing deemed to be unsuitable by the Town for reuse shall become the property of the Contractor, and shall be disposed of as indicated earlier in these Specifications under "Disposal of Surplus Excavated Material". All excavations, disposals and backfill materials shall be included in the unit price under these items. Work will also include stacking, temporary storage, and relocation of all curbing to be reused on this project, and a minimum width of six (6) inches high-early-strength cement concrete shall be placed adjacent to all curb items listed above, and in accordance to the Dedham DPW Design & Construction Standards (see Attachment A).

Payment

Payment for work under these items shall be made at the Contract unit bid price per linear foot or per each as indicated above, and shall include full compensation for furnishing all labor, materials, and equipment, excavation, disposal, curb and its installation, high-early-strength cement concrete as shown on the curb detail, gravel borrow Type "B" for backfill, and any other incidental items necessary for the satisfactory completion of this work as specified.

**ITEM 509.2 SLOPED TO VERTICAL GRANITE TRANSITION PIECE EACH**

Work under this item shall conform to the relevant provisions of Section 501 of the Massachusetts Highway Department 2021 Standard Specifications for Highways & Bridges, the latest supplements and addendum thereto, and the following:

It is intended that this item be used where a transition from sloped granite edging to vertical granite curb is required. Transition pieces shall be in accordance to the Dedham DPW Design & Construction Standards (see Attachment A).

Payment



All wheelchair ramps shall be constructed in accordance with the MHD's Revised Wheelchair Ramp Standards, dated 2001, the latest supplements and addendum thereto.

Sidewalk excavation shall be included in the bid price per square yard. No separate payment will be made under this item.

Encountered various utility service gate boxes that require adjustment, and miscellaneous signs and parking meter posts that require removal and resetting shall be included in the bid price. No separate payment will be made under this item.

If parking meter posts are deemed to be not reusable by the Town, the Dedham Police Department will supply new posts at no cost to the Contractor.

If deemed necessary by the Town to excavate below 8" from top of sidewalk, the extra excavation will be paid for separately under Item 120.1 Unclassified Excavation.

When materials directly under the sidewalk is found to be acceptable by the Town this material can be approved to remain in place.

Payment

Payment for work under these items shall be made at the Contract unit bid price per square yard and shall include full compensation furnishing all labor, materials and equipment, sidewalk excavation, preparation of sub-base, gravel borrow Type "B" if required, fine grading and compaction, forming, furnishing and placing of 4000 PSI cement concrete, expansion joint, and any other incidental items necessary for the satisfactory completion of this work as specified.

<b>ITEM 702.</b>	<b>ASPHALT WALK SURFACE</b>	<b>TON</b>
<b>ITEM 703.</b>	<b>ASPHALT DRIVEWAY</b>	<b>TON</b>

Work under these items shall conform to the relevant provisions of Section 701 of the Massachusetts Highway Department 2021 Standard Specifications for Highways & Bridges, the latest supplements and addendum thereto, and the following:

Sidewalk excavation shall be included in the bid price. No separate payment will be made under this item.

Encountered various utility service gate boxes that require adjustment, and miscellaneous signs & parking meter post that require removal and resetting shall be included in the bid price. No separate payment will be made under this item.

Asphalt installation shall be as follow or as otherwise directed:

Sidewalk

1 ¼" Top Course over  
1 ¼" Binder Course Material

Driveway  
2" Top Course over  
1 ½" Binder Course Material

Payment

Payment for work under these items shall be made at the Contract unit bid price per ton and shall include full compensation for furnishing all labor, materials and equipment, sidewalk excavation, preparation of sub-base, gravel borrow Type "B" if required, fine grading and compaction, forming, furnishing and placing of Asphalt, and any other incidental items necessary for the satisfactory completion of this work as specified.